



P&C

HAND TOOLS

QUALITY TOOLS FOR BUILDING AMERICA

over 1500 hand tools

The BEST TOOLS
money can buy

CATALOG NO. 66200



The BEST TOOLS money can buy BECAUSE...



1. Each tool is designed with the use and the user in mind.



2. Only the finest tool steels and special alloys are used.



3. Fabrication is by skilled master craftsmen who take pride in their work.



4. Every tool must meet rigid piece by piece inspection before it leaves the P & C factory.

THAT'S WHY...

you can buy P & C Tools with confidence. Each is backed by this guarantee:

OFFICIAL GUARANTEE

P & C Tools are America's finest quality tools. They are made from the very best steels and alloys obtainable. No effort is spared in the design, workmanship or final painstaking inspection. Should any P & C tool be found defective in workmanship or material and returned prepaid to the factory it will be replaced or repaired without charge provided it has been used for the purpose for which that tool was designed.

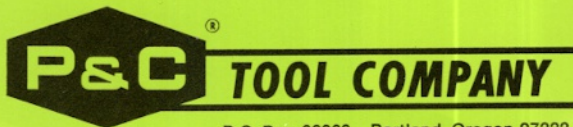

P.O. Box 22066 Portland, Oregon 97222

Wholly owned subsidiary of



NOTICE:

Due to government action, supplier changes or other causes, all prices, finishes, design features and steel analysis or other specifications in this catalog are subject to change without notice.



American Hardware Manufacturers Association

COMPLETE ALPHABETICAL INDEX

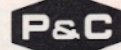

Name	Page	Name	Page	Name	Page
AIR IMPACT WRENCH	44	HAMMERS		SCRAPER, CARBON	51
ALLEN WRENCHES	50	Ball Pien	9	SCRAPER, GASKET	51
ARBORS	36, 64	Brass	10	SCRAPERS, WOOD	75
ATTACHMENTS,		Body and Fender	72, 73	SCREW EXTRACTOR SET	6
SOCKETS	30, 31, 32, 33, 34, 37, 39, 41	Nail	9	SCREW GUIDE	68
AUTOMATIC TRANSMISSION SET	54	Plastic Tip	72	SCREW HOLDING SCREWDRIVER	28
AUTOMOTIVE TOOLS	51, 52, 53, 54	Tack	19	SCREWDRIVERS	27, 28
AWLS	61	HARMONIC BALANCER PULLER	73	Cabinet	27
BALL PEIN HAMMERS	9	HATCHETS	73	Offset	28
BARS		HANDEZE GRIPS	14	Phillips	28
Lining Up Bar	61	HANDLE,		Reed and Prince	27
Rolling Head Bar	61	SOCKET	31, 32, 34, 36, 39, 40, 41	Regular	27, 28
Wrecking Bar	61	HEX KEY (HOLLOW HEAD)	50	Spiral Ratchet	70
BATTERY TERMINAL PULLERS	19	WRENCHES	29	SCREWDRIVER SOCKETS	28, 31, 33, 37
BEARING SEPARATOR AND PULLER	19	HEX NUT DRIVERS	29	SNIPS	64
BENDIX BRAKE ADJUSTING TOOL	53	HOLE SAWS	24	SOCKET ATTACH-	
BENDIX BRAKE PLIERS	16	HOLLOW HEAD SCREW	50	MENTS	31, 32, 33, 34, 37, 39, 41
BEVELS	79	HUB CAP AND GREASE TOOL	16	SOCKET HANDLES	31, 32, 34, 37, 39, 40
BIT BRACES	67	IGNITION GAUGE SET	7	SOCKET SCREWDRIVERS	28, 31, 33, 37
BIT AND ACCESSORIES	67, 68	IMPACT SOCKETS	42, 43	SOCKET SETS	32, 34, 38, 40
Expansive Bits	67	IMPACT WRENCHES	44	SOCKET WRENCHES	
Bit Extension	67	INTERNAL PIPE WRENCH	63	1/4" Drive	31, 32
Power Bit Extension	68	KNIFE BLADES	63	3/8" Drive	33, 34, 35
BODY AND FENDER DOLLIES	10	KNIVES, UTILITY	63, 71	1/2" Drive	36, 37, 38
BODY AND FENDER HAMMERS	10	LEAD PICKING TOOL	66	3/4" Drive	39, 40
BOX WRENCHES	46	LETTERS, STEEL MARKING	29	1" Drive	41
BOXES, TOOL	59, 60	LEVELS	71	Dyna-Ring	42, 43
BRACES	67	LUG WRENCHES	42	Electric Socket Wrench	44
BRAKE BLEEDER TOOL	53	MASON'S HAMMER	72	Impact	42, 43
BRAKE BLEEDER WRENCH	53	MASON'S LEVEL	71	Metric Size	11
BRAKE GAUGE SET	7	MASONRY DRILLS	68	Power	42, 43, 44
BRAKE PLIERS	16	METRIC MEASURE		SOIL PIPE CHISELS	66
BRAKE SHOE TOOL	53	Combination Wrenches	11	SPARK PLUG GAUGE SET	8
BRAKE SPRING PLIERS	16	Open End Wrenches	11	SPARK PLUG SOCKET	36
BRAKE TOOLS	53	Sockets	11	SPRIL RATCHET SCREWDRIVERS	70
BRITISH STANDARD MEASURE		MITRE BOXES	78	SPUD END WRENCHES	50
Combination Wrenches	11	MUFFLER REMOVAL TOOL	52	SQUARES	80
Sockets	11	NAIL PULLER (CAT'S CLAW)	61	STAR DRILLS	65
CHALKERS	65	NAIL SETS	79	STARTER WRENCH	52
CHAIN WRENCH	66	OBSTRUCTION WRENCHES	46	STEEL TAPES	62
CHESTS, TOOL	59, 60	OIL FILTER REMOVAL TOOL	52	STEERING WHEEL PULLERS	19
CHISEL AND PUNCH SETS	4, 5, 76	OVERHEAD VALVE ADJUSTER	52	STEP CUT FEELER GAUGES	7
CHISELS		OVERHEAD VALVE GAUGE SET	8	STEP PLATES PULLER ADAPTER	20
Butt Chisels	76	PHILIPS CROSS SLOT SCREWDRIVERS		STRIKING WRENCHES	50
Cape Chisels	3	Hand Drivers	27, 28	STRUCTURAL WRENCHES	50
COLD CHISELS	3	Socket Drivers	31, 33	STUD REMOVERS AND SETTERS	20
Diamond Point Chisels	3	PIPE EXTRACTORS	6	TACK CLAW	79
Ripping Chisel	61	PIPE REAMERS	66	TACK HAMMER	72
Rivet Shear Chisels	3	PIPE WRENCHES	8	TAP WRENCHES	6
Round Nose Chisels	3	PISTON RING COMPRESSOR	51	TAPE RULES, STEEL	62
Soil Pipe Chisel	66	PITMAN ARM PRY BAR	51	TIN SNIPS	64
Wood Chisels	76	PLANES		TIRE IRON	54
CLIK-STOP WRENCHES	45	Bench Planes	74	TOOL BOXES, CABINETS, CHESTS	59, 60
CONCRETE GADS	66	Block Planes	74, 75	TOOL SETS	
CONNECTING ROD SOCKET	51	Jack Planes	74, 75	Apprentice	58
COTTER PIN PULLER	54	PLIERS	12, 13, 14, 15, 16, 17	Basic	55
COUNTERSINKS	66, 68	PLUMB BOBS	75	Master Maintenance	56, 57
CROW FOOT WRENCHES	34	PLUMBER'S ALL STEEL CHISEL	76	TORQUE WRENCHES	30
DISTRIBUTOR POINT SOCKET	51	PLUMBING TOOLS	65, 66	TRUARC PLIERS	18
DISTRIBUTOR WRENCH	52	PLUMBER'S SPECIAL PLIERS	13	TUBE CUTTING AND FLARING KIT	66
DIVIDERS	76	POWER BIT SET	68	TUBING EXPANDERS	66
DOLLIES, BODY AND FENDER	10	POWER BITS	68	VALVE ADJUSTER	52
DRAG LINK ADJUSTER	51	POWER SOCKETS	42, 43	VALVE GUIDE CLEANER	51
DRAG LINK SHOCK ARM TOOL	51	PULLER SETS	23	VALVE LIFTER	51
DRILL POINT SET	69	PULLERS	19, 20, 21, 22	VICES	26
DRILL POINTS	69	Battery Terminal	19	WHEEL ARBORS	64
DRILLS		Blind Bearing	22	WING DIVIDERS	76
Automatic	69	Harmonic Balancer	19	WOOD CHISELS	
Hand	69	Steering Wheel	19	Butt Chisel	76
Masonry Power	68	Universal Wheel Hub	20	Plumber's All Steel Chisel	76
DYNA-RING [®] SOCKETS	42, 43	PUNCH AND CHISEL SETS	4, 5	Wood Chisels	76
EXPANSION BITS	67	PUNCHES	3, 4	WORK ARBORS	36
EXTENSION BARS	31, 34, 37, 39, 41	PUTTY KNIFE	71	WRECKING BAR	61
EXTRACTORS		RATCHETS	31, 33, 37, 39, 41, 67	WRENCH SETS	49
Screw	6	RATCHETING BOX WRENCHES	67	WRENCHES	
Pipe	6	REED AND PRINCE SCREWDRIVERS	27	Air Impact	44
Stud	6	RIPPING CHISEL	61	Adjustable	45, 46
FEELER GAUGES	7, 8	RIVET HEADER	3	Allen Head	50
FIGURES, STEEL MARKING	29	RIVET SHEAR CHISEL	3	Box	46
FILES, BODY AND FENDER	9	RUBBER MALLET	9	Combination	47
FLARE NUT WRENCHES	48	RUBBER TIP MALLET	9	Crow Foot	34
FORD FUEL FILTER WRENCH	52	RULES		Clik-Stop	45
FORD MASTER GAUGE SET	8	Folding Wood	63	Electric Impact	44
GADS, CONCRETE	66	Steel Tapes	62	Flare Nut	48
GASKET SCRAPER	51	SABRE SAW BLADES	79	Long Offset Box	47
GAUGE SETS	7, 8	SANDERS, HAND	75	Midget	48
GLASS CUTTERS	70	SNAP RING PLIERS	18	Midget Open End	48
GRAB-ALL	54	SAWS		Obstruction	46
GREASE AND HUB CAP TOOL	16	Back Saw	78	Open End	48, 50
GRINDING HEADS	64	Carpenter's Handsaw	78	Pipe	8
HACK SAW BLADES	26	Compass Saw	77	Ratcheting Box	46
HACK SAWS	25	Coping Saw	77	Short Offset Box	47
HAMMER HANDLES	9, 72	Hacksaw Blades	26	Spud End	50
		Hacksaw Frames	25	Striking	50
		Hole Saws	24	YARNING IRONS	65, 66
		Keyhole Saws	77		

Tool Number	Cat. Page	Tool Number	Cat. Page	Tool Number	Cat. Page
000-A-000-E	7	1275-1280	12	3000M	11
000-K	8	1281-1292R	17	3000NR	35
000-M	7	1299	15	3010-3022H	33
000-N-000-R	8	1303L-1332	64	3008M-3019M	11
0015-020/22	7	1345-1361	25	3008S-3016S	33
1	5	1385-1399	18	3071-3072	34
2	4	1368-1419	9	3075	33
2-A	5	1421-1429	10	3100A	35
3	4	1430-1448	9	3112-3126HP	33
USA5-USA10	12	1452-1458	10	3201-3210	34
5 $\frac{1}{16}$ -5 $\frac{3}{4}$	76	1501-1509	9	3211	33
6 $\frac{1}{4}$ -6 $\frac{5}{8}$ x18	66	1541-1556	29	3215-3231	34
14 $\frac{1}{2}$ -033 $\frac{5}{8}$	65	1600-1601	79	3235-3246	33
6-8	5	1602-1605	75	3247-3260	34
P6-P8	12	1606-1611	67	3290 $\frac{1}{8}$ -3324	33
9	4	1612-1635	68	3412-3424	34
9-A-53	3	1640	36	3751-3757	48
113 $\frac{1}{16}$ -12 1 $\frac{1}{8}$	68	1642-1644	67	4000AB	23
13 $\frac{1}{4}$ -13-1	66	1647-1652	68	4000D-4001W	20
AH16-EN-16-1	44	1653-1655	66	4005	19
58-67	4	1656-1657	64	4010B-4030B	22
69	3	1658-1659	36	4032-4034	19
70-88	4	1660-1678B	76	4040-4040-14	20
91-92	3	1679-1681	78	4041-4055R	19
37 $\frac{1}{2}$ -84-1	66	1682-1683	69	4056-4071	21
101-119	61	1684-1685	75	4080-4080S	22
107-110	65	1688-1689	6	4100-4100A	19
112	66	1690-1694	63	4510-4534	20
130-137	48	1695-1697	71	4795	59
130 $\frac{3}{8}$ -132R	65	1698	79	4795-P	32
136 $\frac{1}{2}$ -137 $\frac{1}{2}$	66	1704-1720	46	4796	59
140-142S	65	1704L-1720L	45	4977-4978	50
140-C-140-D	49	1704S-1720S	46	4977-5096	35
152-166	28	1704SL-1720SL	45	5293	11
0200-A-0200FM	32	1725-1731	46	5295-5296	59
0206-0251	31	1801	66	5393	38
0252-0280	32	1806-1824HD	8	5494-5895	59
207	54	1901-1915B	69	5206BS-5212BS	11
230	61	1920-1929	71	6000C-6000K	38
349-351	66	1930-1934S	78	6012-6032S	36
389-395	61	1935-1938	79	6071-6076	37
400	28	1940-1945	74	6100A	38
402-442	27	1946-1948	75	6116-6140	36
452	28	1949-1957	62	6202-6290 $\frac{5}{8}$	37
462-508	27	1958-1960E	63	6306-6371	30
523	28	1961-1962	62	6523-6539	51
542-548	27	1963A-1963SB	79	6540-6541	52
551-559	28	1966-1971B	77	6545-6546	51
562-609	27	1973-1974B	75	6563	16
624	28	1975-1987	70	6601-6735	52
634	27	1990-1992	80	7182P-7479	42
654-660	28	1993	76	07500P-07524L	43
669-710	27	1994-1996	80	8008	72
726	28	1997-1999	26	8167-8316R	73
736-740	27	2005-2015	53	8413-8466	72
752-760	28	2020-2027	62	8516-8516R	73
776-816	28	2106-2120	29	8604-8632	9
828	28	2126-2130	61	8715-8720	73
838	27	2250-2285	47	8912-8924	72
858-862	28	2301	52	8954	9
878	27	2302	51	9071-9209	39
D-0918	60	2303-2304	52	9210	40
924-952	50	2306	54	9211	39
964	28	2316-2337	51	9237	40
D-1113-D-1132	60	2344-2350A	54	9238-9265	39
1175-1176	54	2401	5	9300A-9300NR	40
1180-1196	46	2402	4	9328-9376	39
1200-L-1200-S	14	2402-2407	5	9500A	6
1206BS-1212BS	11	2409	4	9500B-9509	41
D-1216-D-1250	60	2410	49	9521-9529	6
1204-1203	12	2411	4	9537	40
1204-1209	14	2413-2428	49	9552-9612	41
1215-1218A	16	2429	4	9851-9855	28
1220-1228	15	2430	27	9902A	56
1231	13	2500B-2500M	49	9912	55
1234	12	2512-2548	46	9914	58
1235	14	2615-2650SW	50	9960	57
1236-1245	13	2700B-2700F	49	9974	42
1246	12	2700M	11	9991	59
1248P-1248S	13	2708-2764	47	10000-10040	43
1250-1251	16	2712H-2724L	47	30607-32426	11
1252A	17	2700M-2722M	11	HB1018F-HB1232T	26
1257	12	2800B-2800H	49	HS24K-HS80M	24
1260	15	2808-2929	48	HSM2436K	24
1266-1272	14	3000A-3000KK	35	HSM5280M	24

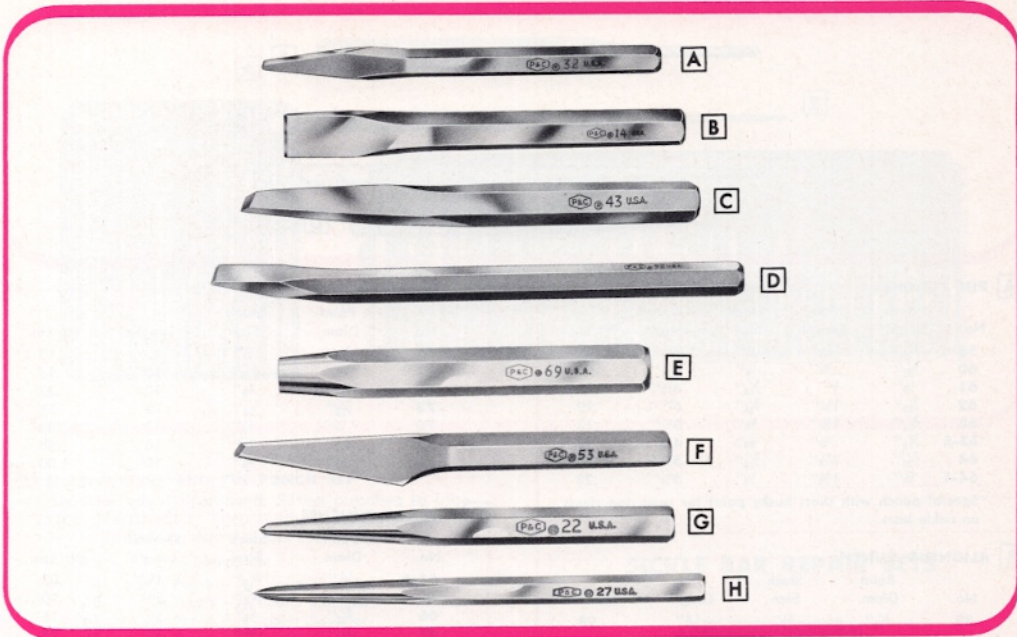

Designed to do their job with speed and efficiency, P&C Chisels and Punches are the best money can buy. Made of special analysis alloy steel, hammer forged for toughness. Cutting bevels are carefully engineered to give lasting efficiency. Every tool is scientifically heat treated to proper temper for maximum edge holding. Heads beveled to prevent mushrooming. Finished in attractive grey satin, sandblasted and lacquer dipped to resist rust.

A CAPE CHISELS

No.	Cut	Stock	Length	Wt. Lbs.
30	3/16"	1/4"	4 1/2"	.08
31	1/4"	3/8"	5 1/4"	.13
32	5/16"	3/8"	5 3/4"	.18
33	3/8"	1/2"	6 1/4"	.30
34	7/16"	5/8"	7"	.45

B COLD CHISELS

No.	Cut	Stock	Length	Wt. Lbs.
9-A	1/4"	3/16"	4 7/8"	.04
10	3/16"	1/4"	5 1/8"	.08
11	3/8"	3/8"	5 3/8"	.13
12	7/16"	3/8"	5 1/2"	.18
12-A	1/2"	7/16"	6"	.26
13	3/8"	1/2"	6 5/8"	.37
14	3/4"	3/8"	7"	.53
15	7/8"	3/4"	8"	.90
17	7/8"	3/4"	12"	1.43
17-A	1"	13/16"	8"	1.16
18	1"	13/16"	12"	1.85
19	1 1/16"	15/16"	12"	2.35

C DIAMOND POINT CHISELS

No.	Cut	Stock	Length	Wt. Lbs.
40	3/32"	1/4"	4 1/2"	.07
41	3/16"	3/8"	5"	.13
42	7/32"	3/8"	5 1/2"	.18
43	1/32"	1/2"	6"	.33

D RIVET SHEAR CHISELS

No.	Cut	Stock	Length	Wt. Lbs.
91	3/4"	3/8"	6"	.45
92	7/8"	3/4"	12"	1.40

E RIVET HEADER

For forming round uniform heads.

No.	Point Diam.	Stock Size	Length	Wt. Lbs.
69	7/16"	3/8"	5"	.40

F ROUND NOSE CHISELS

No.	Cut	Stock	Length	Wt. Lbs.
50	3/32"	1/4"	4 1/2"	.06
51	7/32"	5/16"	5 1/4"	.11
52	3/16"	3/8"	5 3/4"	.15
53	1/4"	1/2"	6 1/4"	.30

G CENTER PUNCHES

No.	Stock Size	Length	Wt. Lbs.
20	1/4"	4"	.05
21	3/16"	4 1/2"	.10
22	3/8"	4 3/4"	.15
22-A	7/16"	4 7/8"	.19
23	1/2"	5"	.25
24	3/8"	6"	.45

H PRICK PUNCHES

No.	Stock Size	Length	Wt. Lbs.
27	1/4"	4 1/2"	.08
28	3/16"	5"	.10
29	3/8"	5 1/2"	.15

All P & C Tools are size marked to speed use on the job.

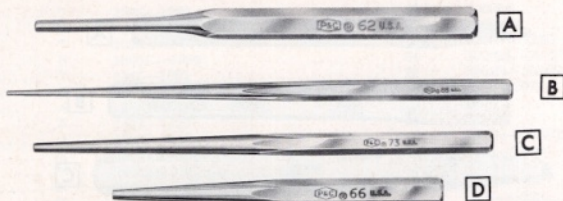
**A PIN PUNCHES**

No.	Point Diam.	Point Length	Stock Size	Overall Length	Wt. Lbs.
58	$\frac{3}{16}$ "	$\frac{3}{4}$ "	$\frac{1}{4}$ "	4 $\frac{1}{4}$ "	.05
60	$\frac{3}{32}$ "	$\frac{3}{4}$ "	$\frac{1}{4}$ "	4 $\frac{1}{4}$ "	.05
61	$\frac{1}{8}$ "	1"	$\frac{5}{16}$ "	4 $\frac{1}{2}$ "	.08
62	$\frac{3}{32}$ "	1 $\frac{1}{4}$ "	$\frac{5}{16}$ "	5"	.10
63	$\frac{3}{16}$ "	1 $\frac{3}{8}$ "	$\frac{3}{8}$ "	5 $\frac{1}{4}$ "	.13
*63-S	$\frac{3}{16}$ "	$\frac{3}{4}$ "	$\frac{3}{8}$ "	4 $\frac{5}{8}$ "	.11
64	$\frac{3}{32}$ "	1 $\frac{1}{2}$ "	$\frac{3}{16}$ "	5 $\frac{1}{2}$ "	.18
64-1	$\frac{1}{4}$ "	1 $\frac{3}{8}$ "	$\frac{1}{2}$ "	5 $\frac{3}{4}$ "	.23

*Special punch with short husky point for removing rivets on sickle bars.

C DRIFT PUNCHES

No.	Point Diam.	Stock Size	Length	Wt. Lbs.
70	$\frac{3}{32}$ "	$\frac{1}{4}$ "	10"	.10
71	$\frac{1}{8}$ "	$\frac{5}{16}$ "	10"	.15
72	$\frac{3}{16}$ "	$\frac{3}{8}$ "	10"	.23
73	$\frac{7}{32}$ "	$\frac{7}{16}$ "	10"	.33
74	$\frac{1}{4}$ "	$\frac{1}{2}$ "	10"	.43
75	$\frac{5}{16}$ "	$\frac{5}{8}$ "	10"	.68
76	$\frac{3}{8}$ "	$\frac{3}{4}$ "	10"	1.00

B ALIGNING PUNCH

No.	Point Diam.	Stock Size	Length	Wt. Lbs.
88	$\frac{3}{16}$ "	$\frac{5}{8}$ "	16"	.98

D STARTER PUNCHES

No.	Point Diam.	Stock Size	Overall Length	Wt. Lbs.
65-A	$\frac{1}{16}$ "	$\frac{3}{16}$ "	4 $\frac{1}{4}$ "	.03
65	$\frac{1}{8}$ "	$\frac{5}{16}$ "	5"	.10
66	$\frac{5}{32}$ "	$\frac{3}{8}$ "	5"	.15
67	$\frac{3}{16}$ "	$\frac{1}{2}$ "	5"	.25



A

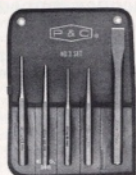

B

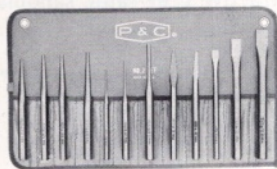

C

A No. 9 UTILITY SET

Supplies the three most used punch and chisel items in a handy, hang-up plastic case of attractive blue vinyl.

Set includes one each of the following:

No.	Description	Wt. Lbs.
12	Cold Chisel — $\frac{3}{16}$ " cut	.45
22	Center Punch — $\frac{3}{8}$ " stock size	
66	Starter Punch — $\frac{3}{32}$ " point diameter 2 $\frac{3}{8}$ " point length	
2409	Plastic Kit	

B No. 3 PUNCH AND CHISEL SET

Contains center, pin and starter punches, plus cold chisels. Many uses for this handy set.

Set includes one each of the following:

No.	Description	Wt. Lbs.
13	Cold Chisel — $\frac{5}{8}$ " cut size	.95
22	Center Punch — $\frac{3}{8}$ " stock size	
61	Pin Punch — $\frac{1}{8}$ " point diameter 1" point length	
63	Pin Punch — $\frac{3}{16}$ " point diameter 1 $\frac{3}{8}$ " point length	
65	Starter Punch — $\frac{1}{8}$ " point diameter 2 $\frac{1}{4}$ " point length	
2411	Plastic Kit	

C No. 2 POPULAR SET

Contains twelve punches and chisels used by master mechanics everywhere. Conveniently arranged in attractive blue vinyl case.

Set includes one each of the following:

No.	Description	Wt. Lbs.
10	Cold Chisel — $\frac{3}{16}$ " cut size	1.55
12	Cold Chisel — $\frac{7}{16}$ " cut size	
12-A	Cold Chisel — $\frac{1}{2}$ " cut size	
22	Center Punch — $\frac{3}{8}$ " stock size	
31	Cape Chisel — $\frac{1}{4}$ " cut size	
41	Diamond Point Chisel — $\frac{3}{16}$ " cut size	
60	Pin Punch — $\frac{3}{32}$ " point diameter $\frac{3}{4}$ " point length	
61	Pin Punch — $\frac{1}{8}$ " point diameter 1" point length	
63	Pin Punch — $\frac{3}{16}$ " point diameter 1 $\frac{3}{8}$ " point length	
65	Starter Punch — $\frac{1}{8}$ " point diameter 2 $\frac{1}{4}$ " point length	
65-A	Starter Punch — $\frac{1}{16}$ " point diameter $\frac{3}{16}$ " stock size	
66	Starter Punch — $\frac{5}{32}$ " point diameter 2 $\frac{3}{8}$ " point length	
2402	Plastic Kit (12 pocket)	



A No. 2-A RIVET AND PIN PUNCH SET
 All sizes you'll ever need. Seven punches in blue vinyl plastic kit to keep them in proper order. Set includes one each of the following:

No.	Description
58	Pin Punch — $\frac{1}{16}$ " point diameter
60	Pin Punch — $\frac{3}{32}$ " point diameter
61	Pin Punch — $\frac{1}{8}$ " point diameter
62	Pin Punch — $\frac{5}{32}$ " point diameter
63	Pin Punch — $\frac{3}{16}$ " point diameter
64	Pin Punch — $\frac{7}{32}$ " point diameter
64-1	Pin Punch — $\frac{1}{4}$ " point diameter
2403	Plastic Kit (7 pocket) Wt. 1.10 Lbs.

B No. 1 MASTER SET — 24 PIECES
 Includes every punch and chisel you'll need for the majority of jobs. And they're all organized in a handy plastic, easy-visibility case to make selection easier and to protect every tool. Set includes one each of the following:

No.	Description
10	Cold Chisel — $\frac{3}{16}$ " cut
11	Cold Chisel — $\frac{3}{8}$ " cut
12	Cold Chisel — $\frac{7}{16}$ " cut
13	Cold Chisel — $\frac{1}{2}$ " cut
14	Cold Chisel — $\frac{3}{4}$ " cut
21	Center Punch — $\frac{3}{16}$ " stock
23	Center Punch — $\frac{1}{2}$ " stock
27	Prick Punch — $\frac{1}{4}$ " stock
30	Cape Chisel — $\frac{3}{16}$ " cut
31	Cape Chisel — $\frac{1}{4}$ " cut
32	Cape Chisel — $\frac{5}{16}$ " cut
33	Cape Chisel — $\frac{3}{8}$ " cut
40	Diamond Chisel — $\frac{5}{32}$ " cut
41	Diamond Chisel — $\frac{3}{16}$ " cut
42	Diamond Chisel — $\frac{1}{8}$ " cut
50	Round Nose Chisel — $\frac{3}{32}$ " cut
52	Round Nose Chisel — $\frac{1}{16}$ " cut
60	Pin Punch — $\frac{3}{32}$ " point diameter
61	Pin Punch — $\frac{1}{8}$ " point diameter
62	Pin Punch — $\frac{3}{32}$ " point diameter
63	Pin Punch — $\frac{1}{16}$ " point diameter
64	Pin Punch — $\frac{7}{32}$ " point diameter
66	Starter Punch — $\frac{3}{32}$ " point diameter
67	Starter Punch — $\frac{3}{16}$ " point diameter
2401	Plastic Kit Wt. 3.80 Lbs.

SICKLE BAR REPAIR SETS



SET No. 6

Here are three chisel and punch sets specifically designed to repair knife sections and ledger plates on harvesting equipment. Each does the job quickly and easily, saves important production time. Come in handy plastic kit.

Sets are made up from the following:

- No. 63-S PIN PUNCH**
Designed for driving out rivets. Short and husky yet long enough to reach through ledger plate and guard.
- No. 67 STARTER PUNCH**
For breaking loose ledger plate rivets.
- No. 69 RIVET HEADER**
For knife section rivets. Forms round, uniform head.
- No. 91 RIVET SHEAR**
For cutting section rivets.
- SET No. 6**
Includes one each of Nos. 63-S, 67, 69 and Plastic Kit No. 2406.
- SET No. 7**
Includes one each of Nos. 63-S, 67, 69, 91 and Plastic Kit No. 2407.
- SET No. 8**
Includes one each of Nos. 63-S, 69, 91 and Plastic Kit No. 2406.



Works on either right or left threads. Drill size clearly marked on each tool. Made of toughest, special alloy steel with sharp fluted edges that gives a positive bite. Gradual taper prevents wedging and binding. Even if the pilot hole is drilled clear through this extractor will not chew up the object as other extractors do. Sizes available to meet all needs.

FOR REMOVING SCREWS, BOLTS, STUDS, PIPE

P&C Extractors are of a unique design that makes removing broken bolts, screws and studs faster and easier. Just these three simple steps:



(1) Drill hole to size specified



(2) Drive in P&C Extractor

(3) Turn out broken object

No.	Drill Size	Minimum Depth of Hole	Size of Shank	U.S.S. Screw Stud or Bolt Size	Pipe Size	Overall Length	Wt. Lbs.
9521	1/8"	3/8"	3/16"	1/4, 5/16"	2 3/4"	.01
9522	3/16"	1/2"	3/16"	3/8"	2 3/4"	.02
*9523	1 3/64"	1/2"	1/4"	1/2"	1/8"	2 3/4"	.04
9524	3/16"	1/2"	3/16"	1/2, 3/16"	1/4"	3"	.06
9525	3/8"	5/8"	3/8"	5/8"	3/8"	3 1/4"	.10
9525B	1 5/32"	1 1/16"	7/16"	3/4"	3 3/8"	.17
9526	9/16"	1 1/16"	1/2"	3/8"	1/2"	4 1/2"	.23
9527	2 1/32"	3/4"	5/8"	1, 1 1/8"	1/2"	4 7/8"	.40
9528	1 3/8"	3/4"	3/4"	1 1/4, 1 3/8"	3/4"	5 3/8"	.65
9529	1 1/16"	3/4"	1"	1 1/2"	1"	5 1/2"	1.12

*For broken Alemit fittings.

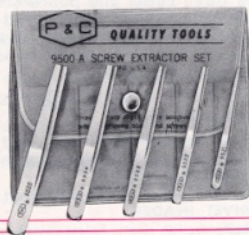

SCREW EXTRACTOR SET

No. 9500-A

The five most used screw extractors in a handy, see-through plastic kit of tough and lasting vinyl. Set includes one each of the following extractors:

Numbers 9521, 9522, 9523, 9524, 9525 Weight .26 Lb.

FOR STUD REMOVERS SEE PAGE 20

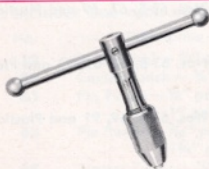

TAP WRENCHES

Handy for holding drills, reamers and other small tools in addition to taps. Knurled chuck shell adjusts easily. Chuck provides a firm grip even when only a small bite is taken. Handle slides for use in tight places.

No.	Handle	Capacity	Wt. Lbs.
1688	3 1/4"	1/8" - 7/32"	.15
1689	5 3/4"	1/4" - 1/2"	.63

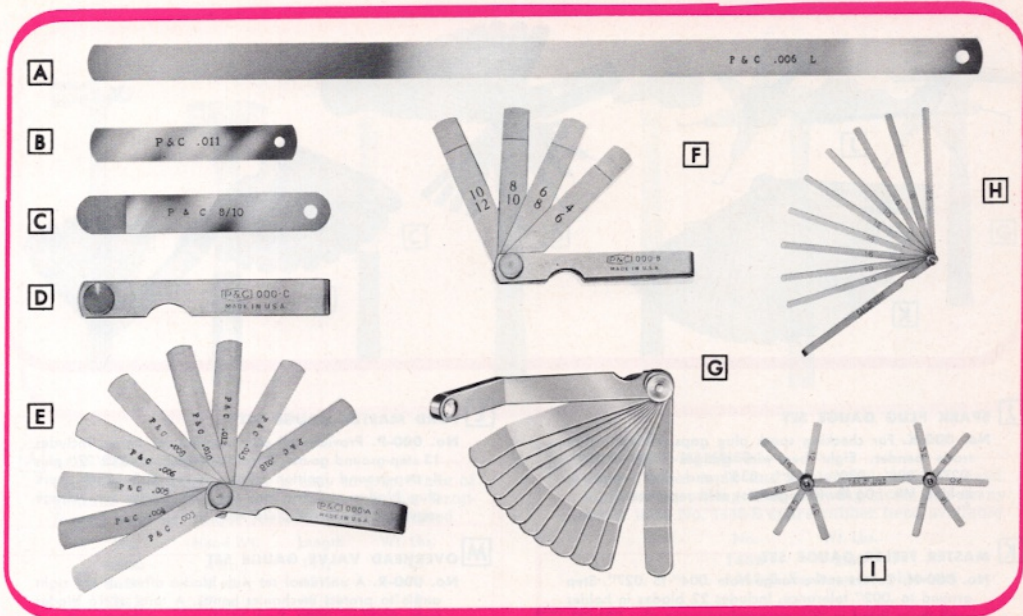

Accuracy, flexibility and careful heat treating that assures long life . . . these are the reasons P&C Feeler Gauges are so popular everywhere.

A LONG BLADES

½" wide, 12" long.

No.	Wt. Lbs.	No.	Wt. Lbs.	No.	Wt. Lbs.
0015-L	.002	013-L	.023	025-L	.040
002-L	.004	014-L	.023	026-L	.041
003-L	.006	015-L	.027	027-L	.043
004-L	.008	016-L	.027	028-L	.046
005-L	.009	017-L	.028	030-L	.050
006-L	.012	018-L	.030	032-L	.054
008-L	.016	019-L	.031	035-L	.057
010-L	.019	020-L	.032	040-L	.070
011-L	.019	021-L	.035		
012-L	.021	022-L	.036		

B SHORT BLADES

½" wide, 3" long.

No.	Wt. Lbs.	No.	Wt. Lbs.	No.	Wt. Lbs.
0015	.001	010	.005	019	.009
002	.001	011	.005	020	.010
003	.002	012	.005	022	.011
004	.002	013	.006	025	.012
005	.003	014	.006	030	.013
006	.003	015	.007	032	.015
007	.004	016	.008	035	.016
008	.004	017	.008	040	.017
009	.004	018	.009		

C STEP-CUT FEELER GAUGES

"Go" and "no-go" gauges, with two different thicknesses on each blade, ½" wide, 3¼" long.

No.	Wt. Lbs.	No.	Wt. Lbs.	No.	Wt. Lbs.
004/6	.002	010/12	.006	016/18	.008
005/7	.003	011/13	.007	017/19	.009
006/8	.003	012/14	.007	018/20	.009
007/9	.004	013/15	.007	019/21	.010
008/10	.004	014/16	.007	020/22	.010
009/11	.004	015/17	.008		

D FEELER GAUGE HOLDER

No. 000-C. For 3" or 3¼" feeler gauge blades. Holds all available sizes. Wt., .05 lb.

E STANDARD FEELER GAUGE SET

No. 000-A. Nine short blades—003, 004, 005, 006, 008, 010, 012, 015 and 018—in 000-C holder. Wt., .09 lb.

MASTER FEELER GAUGE SET

No. 000-AA. 25 short blades 0015 through 040 except 019 in 000-C holder. Wt., .19 lb.

F STEP-CUT GAUGE SET

No. 000-B. Four gauges—004/6, 006/8, 008/10 and 010/12—in 000-C holder. Wt., .06 lb.

MASTER STEP-CUT SET

No. 000-BB. Master set with eight gauges—004/6 through 011/13—in 000-C holder. Wt., .08 lb.

G BENT GAUGE SET

No. 000-M. Eleven ½" by 4⅜" bent blades—.006", .008", .010", .011", .012", .013", .014", .015", .018", .019" and .020"—in holder and plastic pouch. Wt., .15 lb. (Blades not sold separately.)

H BRAKE GAUGE SET

No. 000-E. Nine ¾" wide by 4" long blades—.006", .008", .010", .012", .014", .016", .018", .020" and .025" thick—in holder. Wt., .04 lb. (Blades not sold separately.)

I IGNITION GAUGE SET

No. 000-D. Ten ¾" wide by 1½" long blades—.013", .015", .017", .018", .020", .025", .030", .032", .035", and .040" thick—in holder. Wt., .03 lb. (Blades not sold separately.)

Note: Tool numbers on individual gauges also indicate the gauge thickness in thousands of an inch.

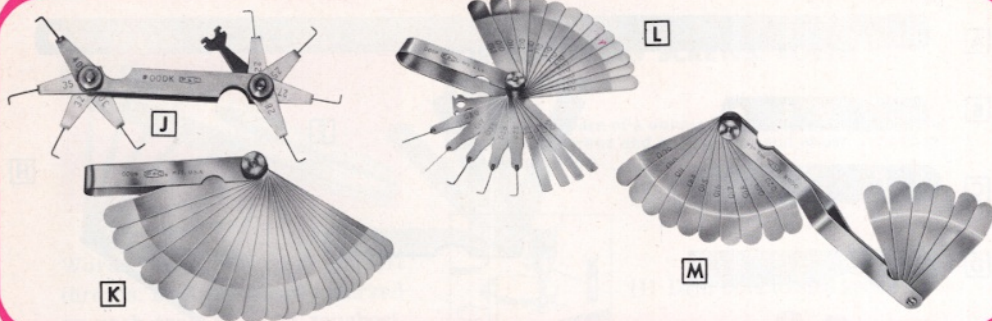
**J SPARK PLUG GAUGE SET**

No. 000-K. For checking spark plug gaps, includes electrode bender. Eight bent-wire gauges—.022", .025", .027", .028", .030", .032", .035" and .040" thick—in holder. Wt., .06 lb. (Gauges not sold separately.)

L FORD MASTER GAUGE SET

No. 000-P. Provides all sizes needed for Fords. Includes 13 step-ground go-no-go from .010/12" to .025/27" plus 4 step-ground ignition blades, three 90° offset spark plug blades and two straight wire blades for voltage regulator setting. Wt., .25 lbs.

K MASTER FEELER GAUGE SET

No. 000-N. Covers entire range from .004" to .027". Step ground to .002" tolerance. Includes 22 blades in holder—all those listed in "C" on previous page plus 021/23, 022/24, 023/25, 024/26, 025/27. Wt., .25 lbs.

M OVERHEAD VALVE GAUGE SET

No. 000-R. A universal set with blades offset at the right angle to protect mechanics hands. A total of 16 blades from .009" to .027". Each blade accurately ground and tempered. Wt., .20 lbs.

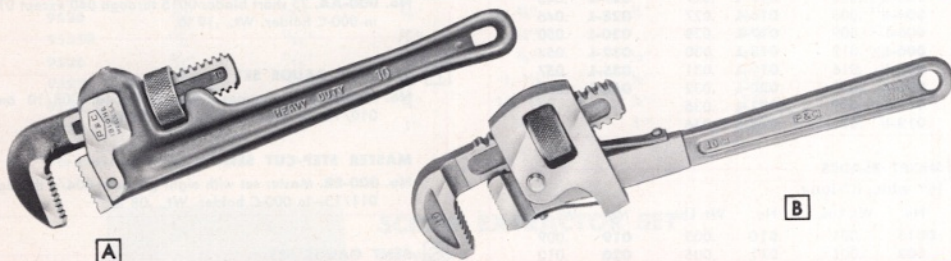

The test of a pipe wrench is the way it stands up under actual professional plumber usage. P&C Pipe Wrenches have met this test time and time again. The right design combined with the toughest of tempered steel is the reason. That's why P&C is the Plumber's Choice.

A HEAVY-DUTY TYPE

Heat-treated, precision milled teeth, replaceable jaw on wrench body recessed into frame to prevent shearing of pin under extreme loads; pipe sizes marked on forged hook jaw, I-beam handle of alloy ductile iron, and alloy steel jaws.

No.	Length	Maximum Pipe Size	Wt. Lbs.
1806-HD	6"	¾"	.45
1808-HD	8"	1"	.85
1810-HD	10"	1½"	1.80
1814-HD	14"	2"	3.50
1818-HD	18"	2½"	5.80
1824-HD	24"	3"	9.60

B NORMAL DUTY STILLSON PATTERN

Strength far exceeds Government normal-duty specifications. Forged and heat-treated special steel handle of panel I-beam type, strengthened strain points, an easy-turning knurl, and hard, tough jaw teeth that are deep-milled for positive grip.

No.	Length	Maximum Pipe Size	Wt. Lbs.
1806	6"	½"	.32
1808	8"	¾"	.65
1810	10"	1"	1.38
1814	14"	1½"	2.60
1818	18"	2"	4.10
1824	24"	2½"	7.30

See Price List for Individual Replacement Parts.

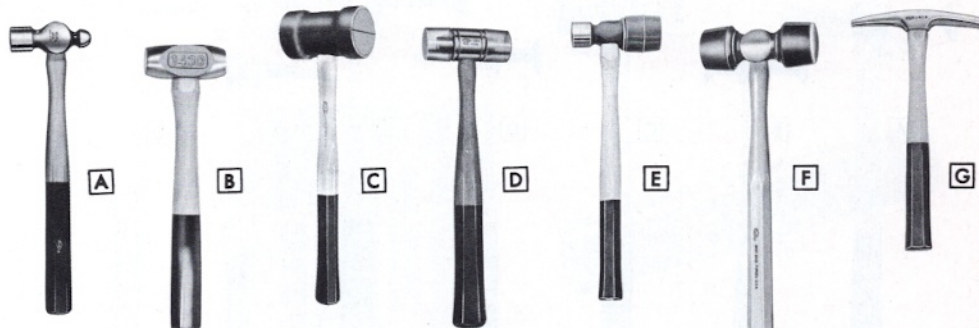

A BALL PEIN HAMMERS

Distinctive octagon handle is easy to grip. Made of genuine hickory with white lacquer finish. Drop-forged head has major surfaces highly polished.

No.	Head Wt.	Length	Wt. Lbs.
8604	4 oz.	11½"	.45
8608	8 oz.	12½"	.70
8612	12 oz.	13½"	1.10
8616	1 lb.	14"	1.40
8624	1½ lbs.	15"	2.00
8632	2 lbs.	16"	2.50

B BRASS HAMMER

This is a 1½-lb. head, all-purpose non-marring hammer for bushings, gears, transmission work, etc. Tapered head for good clearance also minimizes mushrooming.

No.	Wt. Lbs.
1430	1.84

C RUBBER Mallet

Head of soft but tough, non-flaking neoprene. Just the thing to use in garages, service stations, cabinet shops and the like. Head has hour-glass design with 2½" faces.

No.	Wt. Lbs.
1368	1.46

D PLASTIC-TIP HAMMER

Tips are of tough amber plastic. Easily replaceable. Well balanced for less fatigue in use. Tips are 1.5/16" diameter.

No.	Wt. Lbs.
1383	.76

E TWO-WAY HAMMER

Forged steel head and replaceable rubber head. Ideal for mounting tires, drawing rivets and many other jobs. No. 1448-B spare rubber head available.

No.	Wt. Lbs.
1448	2.60
1448-B	(Replacement rubber tip)

F RUBBER-TIP Mallet

A forged steel head mallet with replaceable rubber tips. For use where a metal hammer would cause damage. Ideal for heavy tire work on autos, trucks and tractors. Two-inch rubber tips and selected hickory handle. Replacement tips available.

No.	Wt. Lbs.
8954	1.50
8954-B	(Replacement rubber tip)

G UPHOLSTERER'S HAMMER

Magnetic type. Has long reach and convenient head radii coordinated with natural swing. A truly quality hammer designed and built for the professional upholsterer.

No.	Wt. Lbs.
1419	.57

REPLACEMENT HANDLES FOR HAMMERS

Shaped for an exact fit. Made of the best grade fine grain hickory.

For Hammer No.	Use Handle No.	For Hammer No.	Use Handle No.
1368	1368-H	8612	8612-H
1430	1430-H	8616	8616-H
1448	1448-H	8624	8624-H
8604	8604-H	8632	8632-H
8608	8608-H		

BODY AND FENDER FILES



ADJUSTABLE FILE HOLDER

Made of aluminum, this fender file holder is light but strong. Simple adjustment makes file convex, concave or flat. For use with P&C 1501 File. File not included.

No.	Length	Wt. Lbs.
1509	16"	1.86



FLEXIBLE FLAT STRAIGHT FILE

Fast cutting type for all kinds of body, fender and sheet metal work. Has curved teeth on both sides, seven teeth to inch. Use with P&C 1509 Holder.

No.	Length	Width	Wt. Lbs.
1501	14"	1¾"	.70



You will find P&C Hammers in the finest shops. They are forged from the finest special steels and designed to get the repair job done in the most workmanlike manner. Head and handle are balanced for fatigueless use. Tough hickory handles are firmly fixed.

D FINISHING HAMMER
Has wedge-shaped 1" wide cross pein with 2½" clearance. Has slight crowned 1½" round face with clearance of 2".

No.	Wt. Lbs.
1427	.70

A DINGING HAMMER
Has large face for roughing the bad ones into shape for finishing. Has slightly crowned 1¼" and 1½" diameter round faces. Head is 6" long.

No.	Wt. Lbs.
1421	1.00

E LONG BODY FINISHING HAMMER
Has slightly crowned 1½" diameter round face with 3½" clearance, and a round cross pein, 1½" wide with 4" clearance.

No.	Wt. Lbs.
1426	1.03

B FINISHING HAMMER
Light in weight and perfectly balanced. Has slightly crowned 1¼" diameter round face and a 1-1/16" square face.

No.	Wt. Lbs.
1424	.64

F PECKING HAMMER
Has pointed end for picking out small dents and a round face for finishing. Head is 5½" long overall. Slightly crowned round face is 1½" in diameter.

No.	Wt. Lbs.
1428	.86

C FINISHING HAMMER
Heavier than 1424. Has slightly crowned 1½" diameter round face, and a 1½" square face.

No.	Wt. Lbs.
1425	.90

G PECKING HAMMER
Eliminates uncomfortable reaching. Handle, 17½" reaches to center of car top. Head is 9" long.

No.	Wt. Lbs.
1429	.88

BODY AND FENDER DOLLIES

All are engineered to give usable surfaces and angles. Forged from alloy steel and scientifically hardened and tempered. Have highly polished work surfaces.

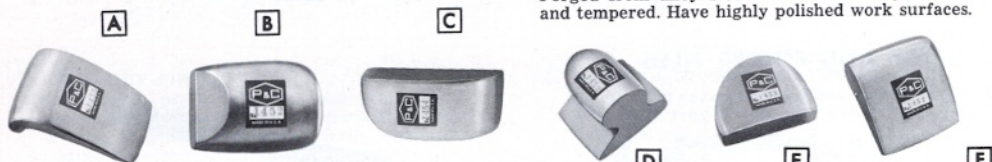

A BEAD DOLLY. No. 1455. Overall size 1¾" x 2³³/₃₂" x 4⁷/₁₆". Wt. 2.40 lbs.

B EGG-SHAPED DOLLY. No. 1452. Overall size 1½" x 2½" x 3¾". Wt. 3.10 lbs.

C RADIUS DOLLY. No. 1454. Overall size 1³/₃₂" x 2³/₁₆" x 4½". Wt. 2.90 lbs.

D RAILROAD OR GENERAL PURPOSE DOLLY. No. 1453. Overall size 2¾" x 2¾" x 2³¹/₃₂". Wt. 2.90 lbs.

E SEMI-ELLIPTICAL HEEL DOLLY. No. 1458. Overall size 1³/₁₆" x 2¾" x 3¼". Wt. 2.20 lbs.

F SHRINKING DOLLY. No. 1457. Overall size 1¼" x 3¹/₁₆" x 3¹/₁₆". Wt. 2.20 lbs.

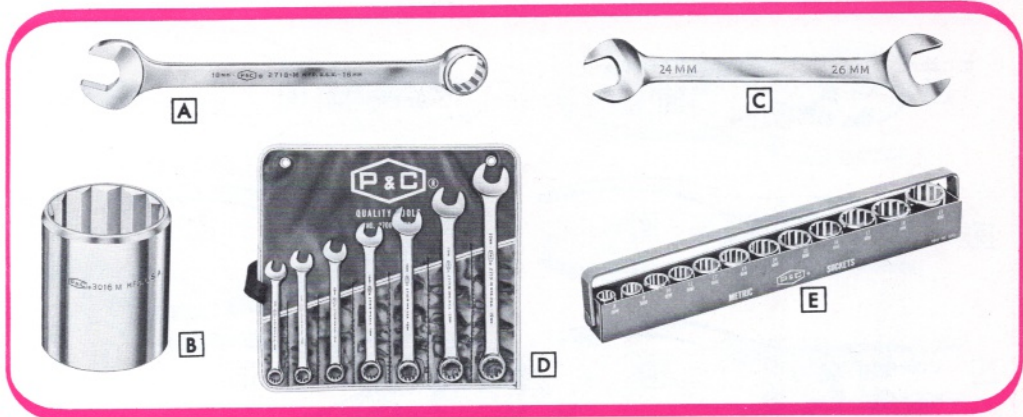

For use on cars, equipment and machinery made in Germany, France, Italy and other countries using the metric measuring system. All are hot forged from special alloy steel and designed for maximum ease in use. Sizes plainly marked to speed selection. Chrome finish for long lasting rust resistance.

A METRIC SIZE COMBINATION WRENCHES

No.	Opening Size In Millimeters	Length, Inches	Wt. Lbs.
2710-M	10	4½"	.06
2711-M	11	5¼"	.10
2712-M	12	5¼"	.10
2713-M	13	6"	.14
2714-M	14	6¾"	.20
2715-M	15	7½"	.27
2716-M	16	7½"	.27
2717-M	17	8¼"	.34
2718-M	18	8¼"	.34
2719-M	19	9¼"	.45
2720-M	20	10¼"	.55
2722-M	22	11¼"	.65

D METRIC COMBINATION WRENCH SET

Set No. 2700-M

Contains one each of the following opening sizes: 11, 12, 13, 14, 16, 17, 19 millimeters.

See listing in first column for overall length and wrench numbers. Vinyl Kit only . . . Part No. 2429. Weight of Combination Set 1.8 lbs.

B METRIC SIZE SOCKETS
¾" SQUARE DRIVE

All are 12 pt to fit and turn nuts in smaller space.

No.	Opening Size In Millimeters	Length, Inches	Wt. Lbs.
3008-M	8	1"	.04
3009-M	9	1"	.04
3010-M	10	1"	.04
3011-M	11	1"	.04
3012-M	12	1"	.05
3013-M	13	1"	.07
3014-M	14	1"	.07
3015-M	15	1"	.07
3016-M	16	1"	.10
3017-M	17	1½"	.10
3018-M	18	1½"	.13
3019-M	19	1¾"	.17

E METRIC SOCKET SET

Set No. 3000-M

This set includes one each of all the ¾" drive, 12-point sockets listed. They are combined in a handy tray with a spill-proof locking band.

Tray only, Part No. 5293. Weight of Set, 1.40 lbs.

C METRIC SIZE OPEN END WRENCHES

This combination of ten wrenches gives complete flexibility between 6 and 26 millimeters.

No.	Opening Size In Millimeters	Length, Inches	Wt. Lbs.
30607	6 x 7	4½"	.04
30809	8 x 9	4¾"	.06
31011	10 x 11	5¼"	.07
31213	12 x 13	5¾"	.12
31415	14 x 15	6¾"	.23
31617	16 x 17	8½"	.30
31819	18 x 19	8¾"	.38
32022	20 x 22	10"	.60
32123	21 x 23	10½"	.56
32426	24 x 26	11½"	.78

BRITISH STANDARD MEASURE

Special sizes in wrenches and sockets designed to give the right fit to bolts and nuts on cars, appliances, machinery and motorbikes built in England.

BRITISH STANDARD COMBINATION WRENCHES

No.	British Standard Size Bolt	Obsolete Whitworth Size	Opening Size	Total Length	Wt. Lbs.
1206-BS	⅜"	⅜"	.338"	4"	.13
1208-BS	¼"	⅜"	.445"	5¼"	.18
1210-BS	⅜"	¼"	.525"	6"	.25
1212-BS	⅝"	⅜"	.600"	7½"	.32

BRITISH STANDARD SOCKETS

The drive end fits standard U.S. ¾" ratchets, attachments and drivers. 12-point design.

No.	British Standard Size Bolt	Obsolete Whitworth Size	Socket Size	Total Length	Wt. Lbs.
5206-BS	⅜"	⅜"	.338"	1½"	.04
5208-BS	¼"	⅜"	.445"	1¾"	.06
5210-BS	⅜"	¼"	.525"	1¾"	.07
5212-BS	⅝"	⅜"	.600"	1¾"	.11

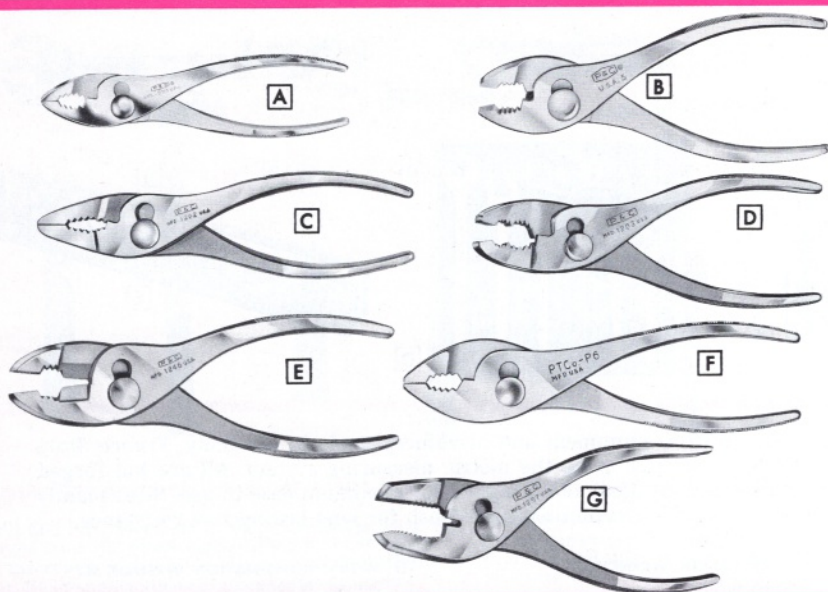

You will find no finer pliers than those with the P&C label. Behind each pair stands years of engineering experience in design and painstaking care in manufacturing. Only the finest special alloy steels are used. Hot forging and tempering assures lasting toughness. Joints work smoothly without sloppiness. Teeth are sharp and induction hardened to stay that way.

A REGULAR SLIP JOINT PLIERS

General utility pliers. Leaders in design and service. Have two jaw-opening adjustments and a shear-type wire cutter. Four sizes. Chrome plate.

No.	Length	Wt. Lbs.
1275	5"	.26
1276	6"	.36
1278	8"	.50
1280	10"	.88

B U.S.A.® ECONOMY PLIERS

Same as regular Slip Joint Pliers except have all-over sand finish.

No.	Length	Wt. Lbs.
USA-5	5"	.26
USA-6	6"	.36
USA-8	8"	.50
USA-10	10"	.88

C THIN JAW SLIP JOINT PLIERS

Designed with a slim nose to reach into tight places. Has two jaw-opening adjustments and shear-type wire cutter. Chromed.

No.	Length	Wt. Lbs.
1201	5"	.25
1202	6"	.35

D BENT NOSE THIN JAW SLIP JOINT PLIERS

Thin jaws offset 30° makes handy nail or staple puller. Fits into places hard to reach.

No.	Length	Wt. Lbs.
1203	7"	.43

E COMBINATION SLIP JOINT CUTTING PLIERS

All the features of slip joint pliers plus durable, induction hardened side cutter.

No.	Length	Wt. Lbs.
1246	6"	.49

F PTCo COMBINATION PLIERS

For the economy minded looking for a rugged plier. Made from special analysis steel with precision broached jaws. The bolt is heat treated, nickel plated and carefully fitted to give smooth performance.

No.	Length	Wt. Lbs.
P6	6"	.50
P8	8"	.50

G HEAVY DUTY UNIVERSAL PLIERS

One jaw curved to grip round or irregular objects, other jaw straight with groove for gripping wire, pins or nails. Deep groove wire cutter.

No.	Length	Wt. Lbs.
1257	7"	.58



"MULTI-PLIER"

Patented, three-piece compound-leverage design multiplies applied pressure ten times! Non-slip jaws open to 1¼". Unique diagonal four-position slip joint gives easy jaw adjustment, reduces wedge action and wear. Alloy steel. Chromed.

No.	Length	Wt. Lbs.
1234*	7¾"	.62

*U.S. Patent No. 2,600,512

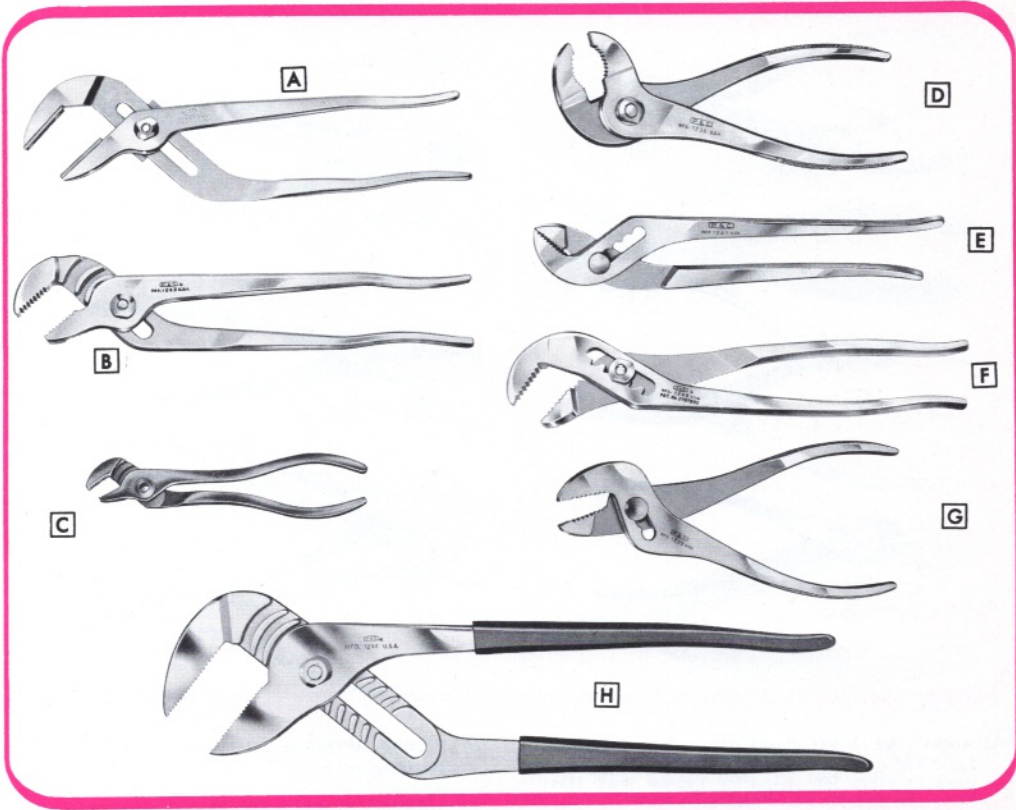

A PLUMBER'S SPECIAL PLIERS
 Comes with either no-mar smooth jaw for use on plated plumbing fixtures or milled pipe jaws. Opens to 2½". Microgroove adjustment permits parallel alignment of jaws.

No.	Length	Wt. Lbs.
12485 (Smooth jaw)	11¼"	.92
1248P (Pipe jaw)	11¼"	.97

B POWER TRACK PLIERS
 A curved tongue-and-groove joint holds jaws securely in any desired position and takes strain off bolt. Five grooves provide wide opening range for handling hundreds of jobs.

No.	Length	Wt. Lbs.
1242	7½"	.45
1243	10"	.75

C POWER TRACK IGNITION PLIERS
 Enable you to get more leverage and a bigger grip for important ignition jobs. Made with care to work smoothly and adjust easily.

No.	Length	Wt. Lbs.
1231	4½"	.08

D PARROT NOSE WRENCH PLIERS
 Combination plier and pipe wrench, with 75° offset nose. Noted for grip. Ideal for pipe and tubing.

No.	Length	Wt. Lbs.
1236	6¼"	.42
1238	7¼"	.59

E GENERAL UTILITY PLIERS
 Commonly known as Water Pump Pliers. All-purpose, with five jaw-opening adjustments. Teeth are shaped as in a pipe wrench, insuring positive grip on round objects. Plenty of leverage.

No.	Length	Wt. Lbs.
1240	9"	.58
1241	9½"	.58

F SELF-ENERGIZING GEAR-LOCK PLIERS
 In this revolutionary pliers bolt slides into slanting gear-type slots. As handles are squeezed, bolt locks in chosen slot and jaw pressure increases. Design eliminates slipping, prevents binding, and permits smooth, visible adjustments in five slots.

No.	Length	Wt. Lbs.
1245	9½"	.75

G WRENCH PLIERS
 Long, slim 20° offset nose and three jaw-opening adjustments. Jaws hold objects in front of center, giving a powerful gripping action.

No.	Length	Wt. Lbs.
1239	8"	.54

H GIANT POWER TRACK PLIERS
 Gives you a giant grip for really big jobs. Opens to 4¼" with full 2" jaws and sharply broached teeth. Can be set to eleven different positions. Plastisol handles for easy grip.

No.	Length	Wt. Lbs.
1244	17"	3.00



A

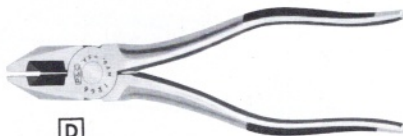

D



B



E



C



F

A MIDGET SLIP JOINT PLIERS

Light and convenient to use. Designed for ignition work or other jobs requiring narrow jaws. Has three jaw opening adjustments.

No.	Length	Wt. Lbs.
1235	4½"	.07

B DIAGONAL CUTTING PLIERS

Thin, narrow jaws work easily in congested places. Useful for switchboard, telephone, ignition, electronic and electrical work. Induction-hardened cutting edges. High quality alloy steel.

No.	Length	Wt. Lbs.
1204	4½"	.20
1205	5"	.21
1206	6"	.37
1207	7½"	.54

C HEAVY DUTY DIAGONAL CUTTING PLIERS

Tremendous leverage from short, powerful jaws set very close to solidly riveted joint. Perfect alignment, leverage, and balance for difficult cutting jobs. Work easily.

No.	Length	Wt. Lbs.
1209	7"	.49

D LINEMAN'S SIDE CUTTING PLIERS

For utility linemen's work, wiring and electrical equipment installation and maintenance. Carefully matched induction-hardened cutting edges. High quality alloy steel. Smooth working.

No.	Length	Wt. Lbs.
1266	6½"	.43
1268	8½"	.81

E 9" HIGH LEVERAGE LINEMAN'S PLIERS**New England Style**

You get up to 50% more leverage than with standard 8-inch pliers because the rivet is closer to the cutting edges. Ideal for cutting No. 8 and other large wire.

No.	Length	Wt. Lbs.
1269	9"	1.10

F END CUTTING NIPPER

Take a sharp, clean cut close to the surface on wires, bolts, rivets. Powerful leverage.

No.	Length	Wt. Lbs.
1272	7"	.60

**"HANDEZE PLASTIC GRIPS"**

Resilient P&C blue plastic tubes slip over plier handles easily to give better, more comfortable grip. Fit tight, stay on permanently. Long wearing, rugged, finest quality plastic. Unaffected by oil and grease. Resist tear and damage. The three sizes available fit practically all pliers.

No.	Size	Length
1200-S	Small	3"
1200-M	Medium	4"
1200-L	Large	5"

P&C Tools — the BEST money can buy.



Electronics workers, electricians, aircraft mechanics and all those craftsmen working in confined places and with small parts appreciate the usefulness of P&C needle nose pliers and associated tools. Every one has been designed by a skilled engineer and manufactured to the highest standards in the industry. Joints work smoothly, cutters cut cleanly, jaws stay parallel and take a tight grip.

A NEEDLE NOSE PLIERS

Has very thin nose for getting into places with restricted clearance. A standard item for all electrical and electronics work. Hand-fitting handles.

No.	Length	Wt. Lbs.
1222	6 $\frac{1}{2}$ "	.28

B LONG, THIN NEEDLE NOSE PLIERS

For precision work in confined places. Nose diameter is $\frac{3}{32}$ ". Made of high quality alloy steel. Ideal for electronic work.

No.	Length	Wt. Lbs.
1223	6"	.13

C LONG, THIN NOSE TELEPHONE PLIERS

Excellent for manipulating wire and wiring. Heavy, flush riveted joint and shear-type wire cutter.

No.	Length	Wt. Lbs.
1260	6"	.25

D LONG REACH NEEDLE NOSE PLIERS

For drawing and looping wire, forming terminals, working in close quarters, and reaching way back into assemblies. Diamond knurled jaws.

No.	Length	Wt. Lbs.
1228	7 $\frac{3}{4}$ "	.36

E NEEDLE NOSE

Ideal combination for electronic, telephone and other electrical work. A good long-reach plier for many types of jobs. High quality alloy.

No.	Type	Length	Wt. Lbs.
1220	without side cutter	6 $\frac{1}{2}$ "	.30
1226	with side cutter	6 $\frac{1}{2}$ "	.28

F CURVED, THIN NEEDLE NOSE PLIERS

Same as No. 1222 plier, except nose is bent at 79° angle. Handy for reaching around objects.

No.	Length	Wt. Lbs.
1225	6"	.28

G DUCK BILL PLIERS

Tapered jaws $1\frac{1}{2}$ " and long handles give powerful leverage. Deeply milled oil tempered teeth give extra grip. Solid riveted joint. A well balanced tool.

No.	Length	Wt. Lbs.
1227	7 $\frac{3}{4}$ "	.37

H WIRE STRIPPER

With adjustable stop to cut the insulation and not the wire. Ideal for fast work. "Handeze" handles for more comfort in use.

No.	Length	Wt. Lbs.
1299*	5"	.10

*U.S. Patent No. 2,868,049

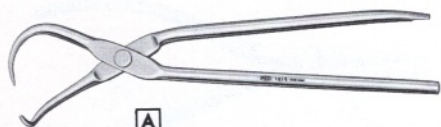

A



B



C

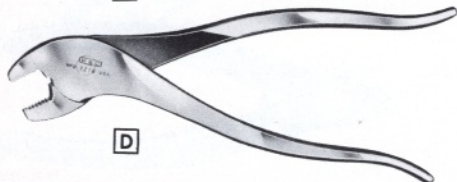

D



E



F



G



H

A BRAKE SPRING PLIERS

Curved jaw clears edge of brake shoe for close adjustment with center line of spring. Thin hooked jaw slips easily under spring.

No.	Length	Wt. Lbs.
1215	12¼"	.61

E BATTERY PLIER - SLIP JOINT

Has 30° angle jaws to turn battery terminal nuts more easily. Slip joint handles wide variety of sizes. Handles shaped for positive grip.

No.	Length	Wt. Lbs.
1218A	8"	.42

F GREASE AND HUB CAP TOOL

All the tools in one to remove hub and grease caps. Also includes a built-in hammer to replace those items. Made of tough alloy steel. Solid rivet joint keeps jaws in positive alignment for many years of use. Black oxide finish prevents rust.

No.	Size	Wt. Lbs.
6563	11"	1.00

B BRAKE PLIERS - BENDIX

Three tools in one! Speeds and simplifies Bendix brake repairs. Special jaws remove hold-down cups. Replaceable Bendix Socket on one handle fits over anchor pin and lug lifts off anchor springs. Other handle end has shovel for replacing anchor pin springs. Tough, high quality alloy.

No.	Length	Wt. Lbs.
1216	11"	.62

G LOCK RING AND "HORSESHOE" WASHER PLIERS

A money-saving dual-purpose plier, for spreading both soft iron "horseshoe" lock washers used on brakes and tempered steel lock rings used on shafting to locate bearings, gears, etc.

No.	Length	Wt. Lbs.
1250	8¼"	.40

H LOCK RING PLIERS - PARALLEL JAW

Powerful compound leverage simplifies removal of lock or snap rings used on shafts to retain bearings. Jaw tip indentations hold two ends of ring, prevents breakage. Outside Jaw Spread 1¼". Chromed finish to prevent rust.

No.	Length	Wt. Lbs.
1251	9½"	.54

D BATTERY PLIERS - ANGLE NOSE

Battery terminal nuts manipulate easily with these thin, 30° offset jaws and long, hand-fitting handles. Jaws give maximum grip regardless of nut condition. Riveted joint for extra strength.

No.	Length	Wt. Lbs.
1218	8"	.49

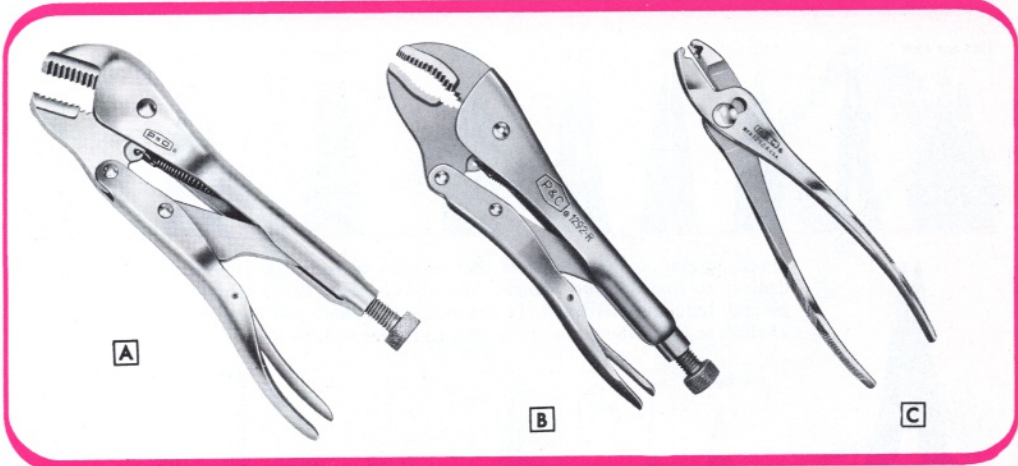

A LEVER WRENCH PLIERS
Probably the most powerful pliers you will find anywhere. Lever action locks the jaws in a holding position with a pressure up to one ton. Can be used as a hand vise, holding clamp or a pipe wrench in addition to a pliers with a grip like a vise. Made of the finest materials and sold with a guaranteed satisfaction warranty.

No.	Type	Length	Wt. Lbs.
1291-R	As illustrated with quick release lever	8"	1
1291	Same as 1291-R without quick release	8"	1

B CURVED JAWS - QUICK RELEASE
Same as No. 1291-R except has curved jaw to take positive grip on pipe. Has quick release lever.

No.	Type	Length	Wt. Lbs.
1292-R	Curved jaw—quick release	9"	1.12

C HOSE CLAMP PLIERS - CORBIN
For installation and repair of Corbin spring tension clamps, used on hose connections for car water pumps and heaters, and other appliances. Two gripping positions engage ears, prevent hazard of clamp flying out of the plier. Chrome plate.

No.	Length	Wt. Lbs.
1252-A	7 3/4"	.50

MIDGET PLIERS



Anyone who has to work in confined places or work with small objects will find P&C Midget Pliers just the ticket. Electronics technicians, hobbyists, electrical equipment workers, aviation mechanics and the like appreciate the smooth operation, balance and hand-fit of these precision tools. Each is designed to do a big job in spite of their petite size. Only the finest of special alloy steels are used. Joints work with ease and cutters are induction-hardened to hold their edge. Together these pliers make a useful matched set.

MIDGET PLIERS				No.	Type	Length	Wt. Lbs.
1281	Straight Nose Plier	4 1/2"	.09	1284	End Cutting Nipper	4"	.10
1282	Chain Nose Plier	4 3/4"	.10	1285	Diagonal Cutting Plier	4"	.08
1283	Round Nose Plier	4 1/2"	.10	1286	Flat Nose Plier	4 3/4"	.09

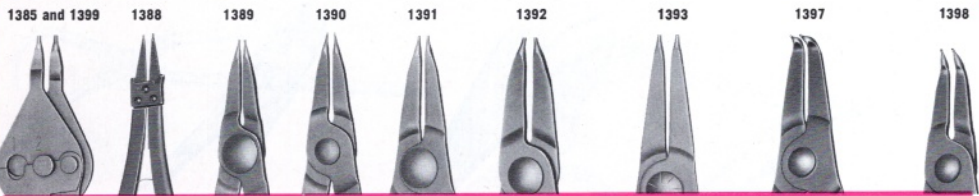

Speed up ring work with pliers that provide correct angle plus firm grip. Avoid damage to rings. Reduce danger from flying rings. Permanent tips are precision ground, inductive hardened. To determine the pliers you need, measure diameter of shaft or bore where ring is located and refer to table below.

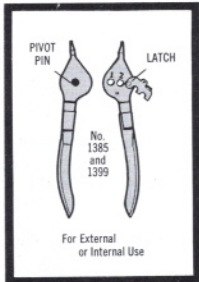
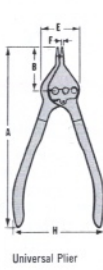
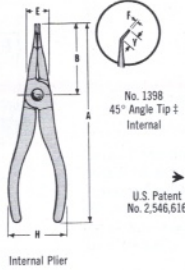
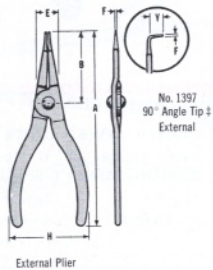

To obtain the right plier, simply measure the diameter of the shaft or bore where the ring is found, and refer to this table.

SHAFT DIAM. RANGE	BORE DIAM. RANGE	PLIER NO.	A (TOL.)	B (TOL.)	E • (TOL.)	F (TOL.)	H • (TOL.)	WEIGHT LBS.
0 - 3/16"	EXTERNAL	1388†	5 1/4"	1 1/8" ± 1/16"	1/2" ± 1/16"	.023 ± .003	1 5/8" ± 1/8"	.0383
1/4" - 7/8"		1391	5 1/4"	2 1/8" ± 1/8"	7/8" ± 1/8"	.038 ± .002	2 5/8" ± 1/4"	.1515
1 3/16" - 1 7/8"		1393	6 1/16"	2 3/8" ± 1/8"	7/8" ± 1/8"	.070 ± .002	2 5/8" ± 1/4"	.2002
1/4" - 7/8"		1397*	5 1/4"	2 3/8" ± 1/8"	7/8" ± 1/8"	.038 ± .002	2 5/8" ± 1/4"	.1562
3/8" - 1"	INTERNAL	1389	5 7/8"	1 7/8" ± 1/8"	1 3/16" ± 1/8"	.038 ± .002	1 1/4" ± 1/4"	.120
		1390	5 7/8"	1 7/8" ± 1/8"	1 3/16" ± 1/8"	.022 ± .002	1 1/4" ± 1/4"	.1405
		1392	6 3/16"	2 1/8" ± 1/8"	7/8" ± 1/8"	.070 ± .002	2" ± 1/4"	.1962
		1398**	5 1/4"	1 3/8" ± 1/8"	1 3/16" ± 1/8"	.038 ± .002	1 1/4" ± 1/4"	.1405
1 3/16" - 1 3/4"	UNIV.	1385	7 7/8"	1 7/8" ± 1/8"	1 1/16" ± 1/8"	.070 ± .002	3 1/4" ± 1/4"	.344
		1399	5 5/8"	1 3/8" ± 1/8"	1 1/8" ± 1/8"	.038 ± .002	1 3/4" ± 1/4"	.17

†U.S. Patent No. 2,901,817. ‡Y—max. 3/16, min. 1/4. *90° Angle Tip. **45° Angle Tip.
• For Universal Plier, dimensions are for: External Position — Internal Position.

If Truarc ring numbers are known, the right plier may be ordered by referring to this table.
EXAMPLE: For External rings 5100-18 thru 5100-23, the correct plier is No. 1388.

TRUARC RING TYPES	EXTERNAL					INTERNAL				
	SERIES 5100 5101 5102	SERIES 5108	SERIES 5000 5001 5002	SERIES N5000 N5001 N5002	SERIES 5008					
Series Dash No.	-18 -23	-25 -87 -143	-50 -100 -200	-100 -106 -175	-25 -37 -93 -156 -175	-75 -137 -200				
Pliers No.	1388	1391 1397 1399	1393 1397 1385	1389 1392 1385	1390 1389 1398 1399	1389 1398 1399				

Note: Series Dash Numbers are in hundredths of inches. Thus, 5100-25 identifies External Ring Series 5100 for a shaft of approximately 0.25" O.D.
© TRUARC is a registered trademark of Waldes-Kohneer, Inc.

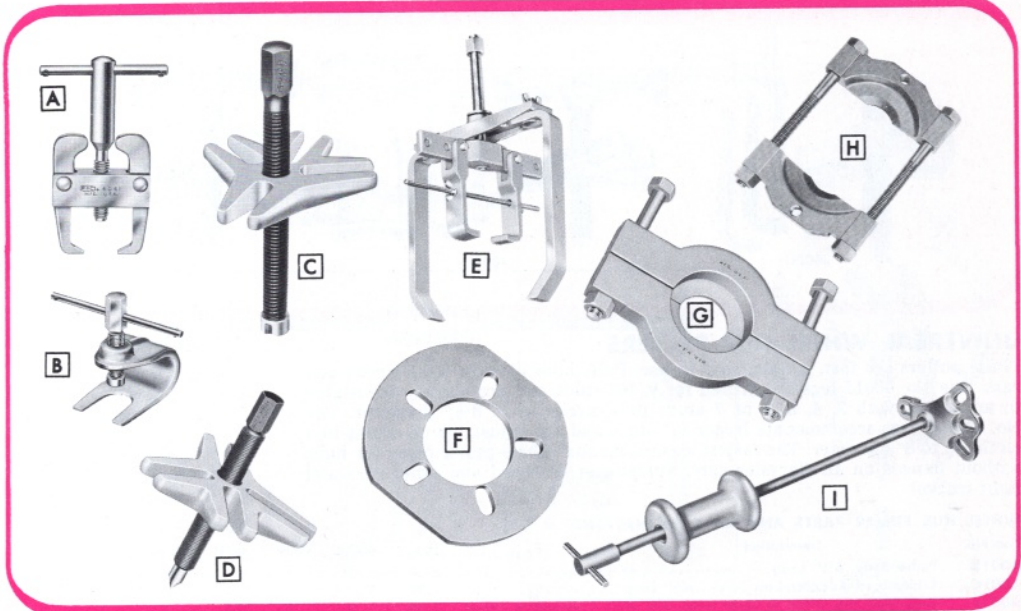

A BATTERY TERMINAL PULLER
Conventional Type
 This puller can also be used for removing small bearings. Has quick, positive action.

No.	Wt. Lbs.
4041	.65

B BATTERY TERMINAL PULLER . . . Special
 Unique design does the job faster. This tool is also more economical than the conventional. Even the most stubborn terminals come loose without harm to the battery.

No.	Wt. Lbs.
4042	.44

C STEERING WHEEL PULLER
 Removes drilled and tapped steering wheels, and ideal for many other cap screw pulling jobs. Holds two diametrically opposed cap screws or three screws 120° apart. Rotatable screw tip is slotted to prevent interference with horn button wiring. Complete puller consists of No. 4043B body, No. 4043S screw with tip. Extra tip is No. 4043T.

No.	Description	Wt. Lbs.
4043	Complete Puller	1.20

D HARMONIC BALANCER PULLER
 Works on all recent model cars with two or three tapped holes on harmonic balances, timing gears. Works on many other pulling jobs.

No.	Description	Wt. Lbs.
4005	Complete Puller	3.00

E REAR AXLE PULLER SET
 Just the thing for pulling flange type or tapered axles on cars or light trucks. Works with No. 4033 Bearing Plate and No. 4034 Flange Plate. Large screw gives tremendous pulling power. Made of heat treated special alloy steel. Handy metal storage box available. See price list for parts.

No.	Description	Wt. Lbs.
4100	Rear Axle Puller Set	13.60
4100A	Same in No. 4100MB Metal Box	19.10

F AXLE FLANGE PLATE
 Bolt this No. 4034 Flange Plate to studs with No. 4033 Bearing Puller behind the bearing and you're ready to pull frozen bearings from auto and truck axles.

No.	Description	Wt. Lbs.
4034	Axle Flange Plate	3.33

G REAR BEARING PULLER ADAPTER
 Works with No. 4034 Flange Plate and No. 4100 Puller to free stubborn bearings without torch heating and hammering. Consists of two (2) No. 4033B plates and two (2) No. 4033S bolt and nut.

No.	Description	Wt. Lbs.
4033	Rear Bearing Puller Adapter	7.75

H BEARING SEPARATOR AND PULLER
 Flat surfaces, thin edges permit adjustment behind many gears, bearings, etc., where space is too limited for puller hooks. Protects expensive bearings. Also ideal as an arbor press bed plate. Overall width, 5-13/16". Top and bottom holes are 1/2-13 thread. Set consists of (2) No. 4032S, bolts and nuts, No. 4032A top plate, and No. 4032B bottom plate.

No.	Description	Max. Opening	Wt. Lbs.
4032	Complete Puller	4" x 4 1/2"	4.40

I REAR AXLE HAMMER PULLER
 The easiest way to remove rear axles. Big 5 1/2-lb. hammer gives real drive. Four-slot adapter fits 4, 5 or 6-bolt or stud (5 1/2" circle range) on flange type axles. Slide hammer is heavy duty malleable iron. All other parts are forged alloy steel. Set consists of 4055B body, 4055H slide hammer and 4055R rod.

No.	Description	Wt. Lbs.
4055	Rear Axle Hammer Puller Set	9.56

*Quicker . . . simpler . . . fewer parts.
 These three words describe the complete line of P&C Pullers.*

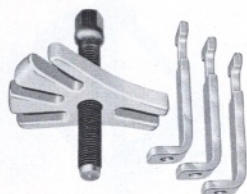

4000D



4001



4001F

UNIVERSAL WHEEL HUB PULLERS

These pullers are fast, simple, easy to use. Pulls hubs of most light trucks and cars. The No. 4001J legs are drilled for 9/16" studs and are quickly adjustable to any drum with 3, 4, 5, 6 or 7 studs in a circle up to 6 1/2" diameter. The No. 4001JT legs accommodate larger 3/4" studs and are adjustable on drums in a circle up to 8" diameter. The fastest, easiest manual wheel puller made for hubs without flanges on all Chrysler cars, Studebaker, Packard and other cars and light trucks.



WHEEL HUB PULLER PARTS AND SET COMBINATIONS

Tool No.	Description
4001B	Puller Body, 6 3/4" Long
4001C	Older Ford Adapter Cap Screw, 4 1/2" Long
4001J	Leg—1 5/16" Leg Offset to Clear Hubs, 3 7/8" from Crossarm to Offset
4001JT	Leg—1 3/4" Leg Offset to Clear Hubs, 3 7/8" from Crossarm to Hub
4001R	Older Ford Adapter Ring
4001S	1" Puller Screw, 8" Long, with 4001ST Tip
4001ST	Detachable Tip for 4001S Screw
4001T	Steel Box, 10 3/4" x 8 1/4" x 1 3/4"
4001W	Striking Wrench

Wt. Lbs.	Parts in Sets					
	4000D	4000E	4001	4001A	4001F	4001G
3.60	1	1	1	1	1	1
.38	2	2
1.00	3	3	3	3	3	3
1.00
.64	1	1
1.43	1	1	1	1	1	1
.06
2.20	..	1	..	1	..	1
2.00	1	1
	8.03	10.23	9.43	11.63	10.70	12.23

Set Wt., Lbs.



STEP PLATES

Used on hollow shafting or housings as base for puller screw to force off bushings, gears, etc., also for installing oil seals.

No.	Small Diam.	Large Diam.	Wt. Lbs.
4040-1	3/4"	1"	.05
4040-2	7/8"	1 1/8"	.08
4040-3	1"	1 1/4"	.10
4040-4	1 1/8"	1 3/8"	.13
4040-5	1 1/4"	1 3/4"	.19
4040-6	1 3/8"	1 7/8"	.22
4040-7	1 1/2"	1 7/8"	.28
4040-8	1 5/8"	2"	.33
4040-9	1 3/4"	2 1/8"	.40
4040-10	1 7/8"	2 1/4"	.49
4040-11	2"	2 1/2"	.59
4040-12	2 1/8"	2 3/4"	.65
4040-13	2 1/4"	2 3/4"	.76
4040-14	2 3/8"	2 7/8"	.83

No. 4040 Set. Eleven sizes Step Plates, 4040-1 through 4040-11. Wt., 3.00 lbs.

STUD REMOVERS AND SETTERS



MANUAL REMOVER

Available in both 1/2" and 3/4" square drive for regular and heavy duty use. Each unit includes two wedges to increase the usable range. Storage for wedges provided in the unit (held in place by a snap-in pin).

No.	Description	Drive For Studs	Diam.	Length	Wt. Lbs.	
4515	Stud Remover, complete	1/2"	1/4"-3/8"	1 1/16"	3 1/2"	.78
4516	Thick wedge for 1/2" drive		1/4"-3/16"			.07
4517	Thin wedge for 1/2" drive		1/2"-3/8"			.04
4532	Stud Remover, complete	3/4"	5/8"-1"	2"	5 1/8"	3.40
4533	Thick wedge for 3/4" drive		5/8"-3/4"			.34
4534	Thin wedge for 3/4" drive		3/4"-1"			.18

POWER DRIVE

Sets or removes 3/8" to 5/8" studs and bolts. Fastest, most efficient design available. Has single, reversible wedge forced against the stud by a spring. Safe, fast, positive. All parts complete in one unit. Nothing to loose or misplace. Works on 1/2" power or manual drive.

No.	Description	Drive	For Studs	Length	Wt. Lbs.
4510	Power Drive Stud Remover and Setter	1/2"	3/8"-5/8"	3 1/2"	1.00



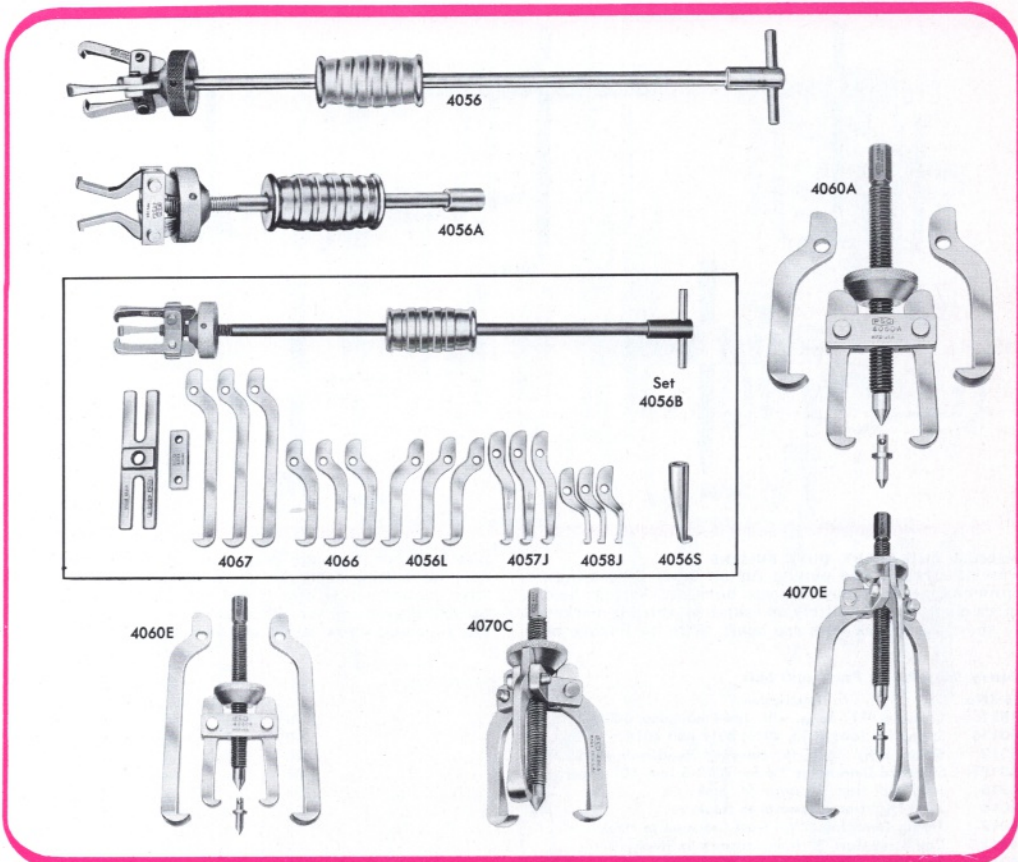

LIGHT DUTY AND SLIDE-HAMMER PULLERS

These small pullers are designed to pull small gears, pulleys, bearings, etc., quickly and easily. Applications include repairs of electric motors, refrigerators, oil pumps, starters, generators, etc. The narrow jaws get

into very close places. Adjusting nut No. 4063 holds the jaws firmly in position so they can't slip. If adjusting nut No. 4056-N is substituted, the short jaws can be reversed and used for inside pulling. Any 1/2" opening wrench can be used on the screw's hexagon head.

Light Duty and Slide Hammer Pullers, Parts and Set Combinations

Tool No.	Description	Wt. Lbs.	Parts in Sets						
			4056	4056A	4056B	4060A	4060E	4070C	4070E
4022	Screw, 6 3/4" Long, 1/2" Hex. Head, with 4022T & 4022TS Tip	.35	1	1	1	1
4022T	Standard Detachable Tip for 4022 Screw 60° Taper	.03
4022TS	Small Detachable Tip for 4022 Screw, 1/4" Diameter	.02
4056C	Slotted Cap Screw Pulling Crossarm, 6" Wide	1.10	1
4056H	Sliding Hammer with Fluted Grip	2.70	1	1	1
4056J	Reversible Jaw, 3 1/2" Long, 2" Yoke to Hook, 1 1/4" - 3 1/4" Inside and 0" - 2 1/8" Outside Ranges	.11	3	..	3	2	2
4056L	Inside Jaw, 4 3/8" L, 3" Yoke to Hook 1 1/8" - 6" Range	.21	3
4056N	Knurled Reversible Adjusting Nut 2 1/2" Diameter	.75	1	1	1
4056PN	Pin for Holding Jaw in Yoke	.03	3	2	3	2	2	3	3
4056R	T-Handled Rod, 24" Long	1.90	1	..	1
4056RS	Short Rod, 12 3/8" Long, for Close Places and for Assembling Valve or Blind Bearing Puller	.96	..	1
4056S	Single Jaw, 2 1/8" L, for Wheel Alignment Brakes, Pulling Grease Retainers, Small Bearings, etc.	.17	1
4057J	Long Reversible Jaw, 4 3/8" Long, 3 3/8" Yoke to Hook, 1 1/4" - 3" Inside and 0" - 4 3/4" Outside Range	.18	3
4058J	Inside Jaw, 3 1/4" L, 1 1/4" Yoke to Hook 3/8" - 2" Range	.10	..	2	3
4061	Yoke, 2 1/2" Wide for Holding Two Jaws	.23	..	1	1	1	1
4063	Knurled Non-Reversible Adjusting Nut, 1 3/4" Diameter	.28	1	1	1	1
4066	Outside Jaw, 4 1/2" L, 3" Yoke to Hook 0" - 4 3/8" Range	.21	3	2	..	3	..
4067	Long Outside Jaw, 7 3/2" L, 6 1/4" Yoke to Hook 0" - 6 7/8" Range	.30	3	..	2	..	3
4071	Yoke, 2 1/2" Diameter for Holding Three Jaws	.32	1	..	1	1	1
4080	Blind Bedring Puller	.34
	Set. Wt.		6.09	4.90	10.59	1.56	1.70	1.67	1.94

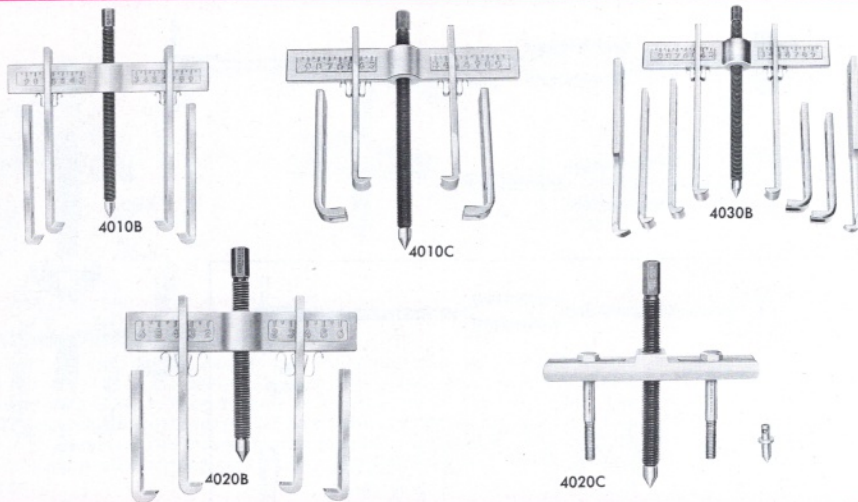

MEDIUM AND HEAVY DUTY PULLERS

Provide straight line pulling for all types of bearings, sprockets, gears, pulleys, wheels, hubs, etc. Springs hold quick-change jaws securely on crossarm which is marked to show the inches jaws are apart. With no linkage or

pins to adjust, they are easy to set up. Some jaws have hole for bolting together, extending reach. Detachable "live center" screw tips do not rotate when a screw is turned, preventing shaft damage, keeping screw on center, relieving screw strain and better alignment.

Heavy Duty Puller Parts and Sets

Tool No.	Description	Wt. Lbs.	Parts in Set			
			4010B	4010C	4030A	4030B
4011	Crossarm, 11" Long, with Jaw-Positioning Guide.....	2.70	1	1	1	1
40115	Spring for Jaws 4015, 4016, 4017 and 4018.....	.02	2	2	2	2
4012	Screw, 11 $\frac{1}{16}$ " Long, $\frac{5}{16}$ " Hexagon Head, with 4012T Tip.....	1.20	1	1	1	1
4012T	Standard Detachable Tip for 4012 Screw, 60° Taper.....	.06
4015	Jaw, 4 $\frac{3}{4}$ " from Crossarm to Hook.....	.94	2	2	2	2
4016	Jaw, 7 $\frac{3}{16}$ " from Crossarm to Hook.....	1.26	2	..	2	2
4017	Timing Gear Jaw, 7 $\frac{3}{16}$ " from Crossarm to Hook.....	1.14	2	2
4018	Cap Screw Jaw, 3" from Crossarm to Hook.....	.88	..	2	2	2
4019	Steel Box, 11 $\frac{1}{16}$ " x 11 $\frac{1}{4}$ " x 1 $\frac{1}{4}$ ".....	4.10	1	..
	Set Wt.		8.38	7.62	16.60	12.50

Medium Duty Puller Parts and Sets

Tool No.	Description	Wt. Lbs.	Parts in Set		
			4020A	4020B	4020C
4021	Crossarm, 7" Long with Jaw-Positioning Guide.....	1.00	1	1	..
40215	Spring for Jaws 4025, 4026 and 4027.....	.01	2	2	..
4022	Screw, 6 $\frac{3}{4}$ " Long, $\frac{1}{2}$ " Hexagon Head, with 4022T and 4022TS Tips.....	.35	1	1	1
4022T	Standard Detachable Tip for 4022 Screw, 60° Taper.....	.03
4022TS	Small Detachable Tip for 4022 Screw, $\frac{1}{4}$ " Diameter.....	.02
4025	Jaw, 2" from Crossarm to Hook.....	.33	2	2	..
4026	Jaw, 4" from Crossarm to Hook.....	.50	2	2	..
4027	Narrow Jaw, 4" from Crossarm to Hook.....	.35
4028	Cap Screw, Case Hardened, 3" Long.....	.10	2
4029	Steel Box, 7" x 7" x 1 $\frac{1}{4}$ ".....	1.74	1
4056C	Cap Screw Crossarm, 6" Wide.....	1.10	1
	Set Wt.		4.79	3.05	1.65

BLIND BEARING PULLER

Simple, efficient, collect-type pulls Chevrolet, Ford and Packard pilot bearings quickly, without damage. Turning screw expands outer shoulder and grips bearing. Expands to 11/16" diameter. Has many other uses. Can be used alone or with No. 4056 Slide-Hammer Puller.



No.	Description	Length	Wt. Lbs.
4080	Complete Puller	4 $\frac{1}{2}$ "	.34
4080B	Spare Body		
4080S	Spare Screw		

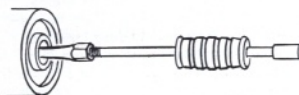

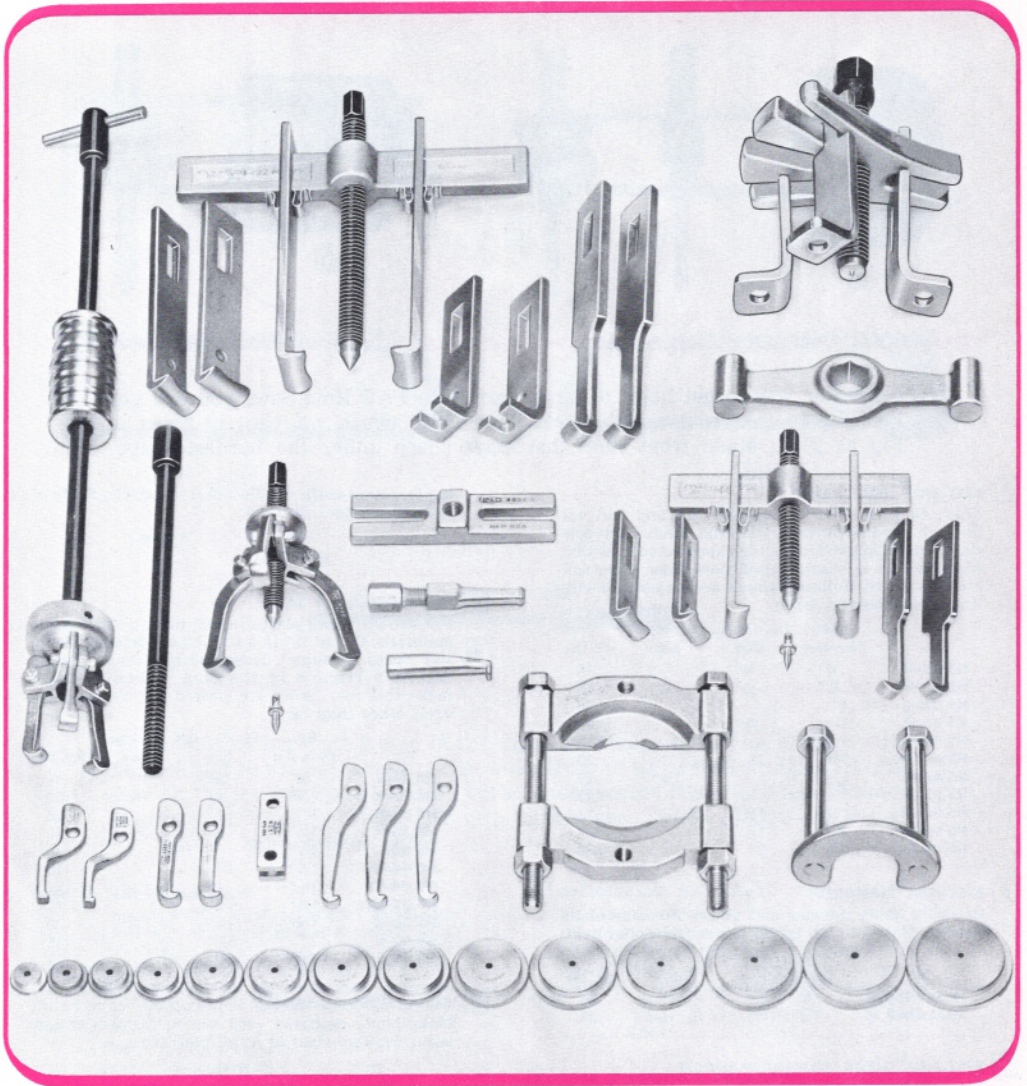

MASTER PULLER SET—No. 4000AB

With this set you will never have a puller problem that you can't lick. Interchangeability of parts makes for maximum use and efficiency. An ideal set for the shop that must be completely equipped.

Tool No.	Description	Quantity	Tool No.	Description	Quantity
4001	Universal Wheel Puller.....	1	4056	Slide-Hammer Puller.....	1
4001-W	Striking Wrench.....	1	4056-C	Cap Screw Crossarm.....	1
4020-B	Medium Duty Puller.....	1	4056-J	Reversible 3½" Jaw.....	2
4027	Narrow Jaw.....	2	4056-RS	Short Puller Rod.....	1
4030-B	Heavy Duty Puller.....	1	4056-S	Single Puller Jaw.....	1
4032	Bearing Separator.....	1	4057-J	Reversible 4½" Jaw.....	3
4040	Step Plate Adapter Set.....	1	4058-J	Pilot Bearing Jaw.....	2
4040-12	Step Plate Adapter.....	1	4061	Yoke for Two Jaws.....	1
4040-13	Step Plate Adapter.....	1	4070-C	Light Duty Puller.....	1
4040-14	Step Plate Adapter.....	1	4080	Blind Bearing Puller.....	1

Set Wt. Lbs. 52.00

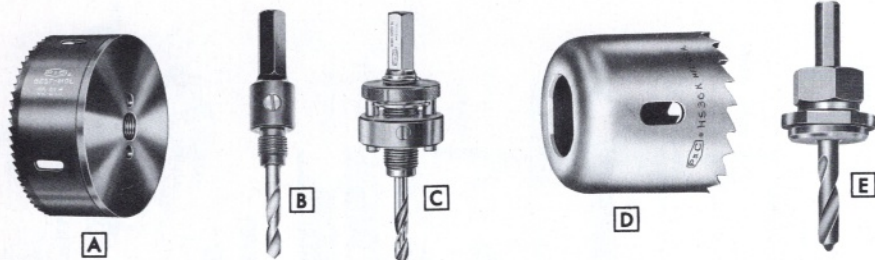

No better way to get holes of large size. With P&C Hole Saws you can get holes up to 1 1/8" with a 1/4" chuck. With 7/16" chuck you can cut holes as big as 2 1/2". Made from steel that stays sharp under the hardest usage.

A BEST-MOL[®] HOLE SAWS

These Saws are for high speed use and will cut through any machineable material. Made from special formula molybdenum high speed steel. Cutting edge welded to shatterproof steel back. Give full 1 1/8" cut depth. Follow-through design permits cutting to any desired depth.

No.	Saw Diameter	For Conduit Size	For Pipe Size	Wt. Lbs.
HS 24-M	3/4"	3/8"		.18
HS 28-M	7/8"	1/2"	3/4"	.18
HS 32-M	1"			.18
HS 36-M	1 1/4"	3/4"	1"	.20
HS 40-M	1 1/4"			.20
HS 44-M	1 3/4"	1"		.20
HS 48-M	1 1/2"		1 1/4"	.21
HS 52-M	1 5/8"			.22
HS 56-M	1 3/4"	1 1/4"	1 1/2"	.24
HS 64-M	2"	1 1/2"		.27
HS 80-M	2 1/2"	2"		.36

B BEST-MOL[®] MANDRELS

Securely holds the saw and allows for easy blade change. Has 1/4" high speed replaceable pilot drill.

No.	Fitting Saws Between Sizes	Shank	Wt. Lbs.
HSM 2436 M	3/4" - 1 1/8"	7/16" Hex	.25
HSM 4048 M	1 1/4" - 1 1/2"	7/16" Hex	.38

C BEST-MOL[®] QUICK CHANGE MANDREL

Has precision ground thread that permits fingertip adjustment. Does not require removal of mandrel from chuck for blade changes.

No.	Fitting Saws Between Sizes	Shank	Wt. Lbs.
HSM 5280 M	1 1/4" - 2 1/2"	7/16" Hex	.63

Replacement Drills for Best-Mol mandrels. Made of high speed steel. Size 1/4".

No.	Wt. Lbs.
HSM 8 D	.01

D BEST-QUIK[®] HOLE SAWS

For use on wood, plasterboard, plastic and similar materials. Cut to 7/8" in a single pass. Special exclusive "pass through" design permits even deeper cuts with removal of the plug. Knock-out holes make this easy. Saws are slotted for use on mandrels other than P&C.

No.	Saw Diameter	For Conduit Size	For Pipe Size	Wt. Lbs.
HS 24-K	3/4"	3/8"		.08
HS 28-K	7/8"	1/2"	3/4"	.08
HS 32-K	1"			.08
HS 36-K	1 1/8"	3/4"	1"	.10
HS 40-K	1 1/4"			.10
HS 44-K	1 3/8"	1"		.10
HS 48-K	1 1/2"		1 1/4"	.11
HS 52-K	1 5/8"			.12
HS 56-K	1 3/4"	1 1/4"	1 1/2"	.13
HS 64-K	2"	1 1/2"		.15
HS 80-K	2 1/2"	2"		.21

E BEST - QUIK[®] MANDRELS

Make blade changing easy and hold the hole saw securely. Two sizes to fit all hole saws.

No.	Fit Saws Between Sizes	Shank	Wt. Lbs.
HSM 2436 K	3/4" - 1 1/8"	1/4"	.13
HSM 4080 K	1 1/4" - 2 1/2"	5/16"	.16

Two types of P&C Hole Saws for big holes in all kinds of materials.

With Best-Mol Hole Saws you can saw holes in any metal that is machineable. And for lighter use on metals plus wood, plaster, plastic, hardboard you will find Best-Quik the hole saw that gets the job done smoothly and quickly. Matching mandrels assure accurate alignment and true holes.

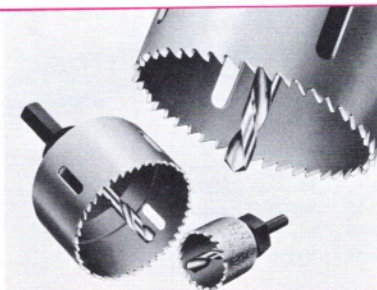

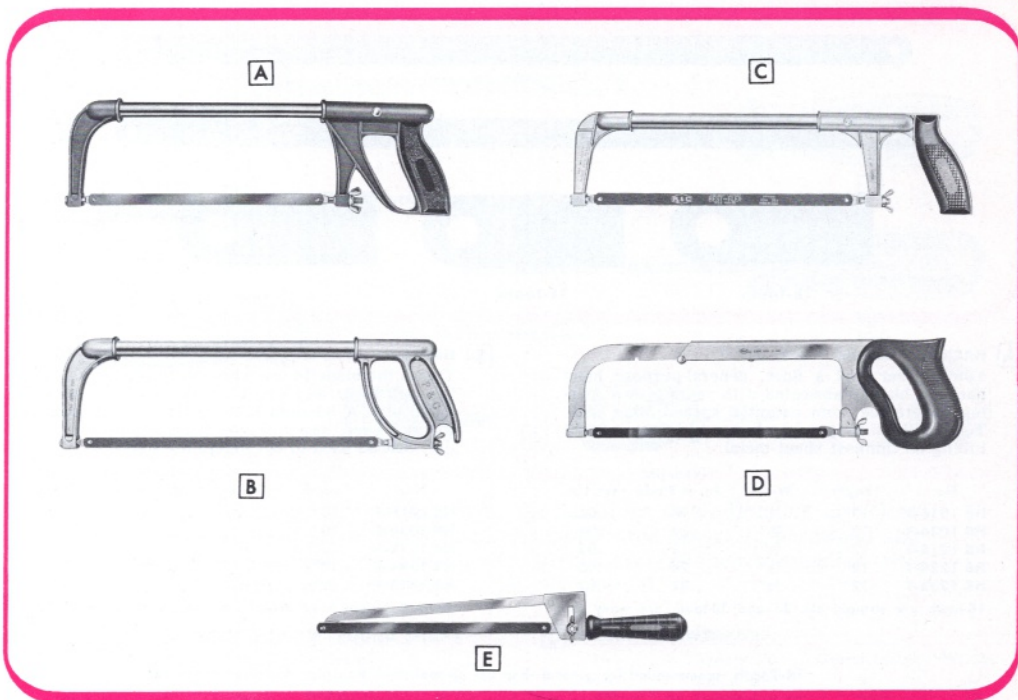

The test of a hacksaw frame is the rigidity it imparts to the blade . . . the flexibility it has in actual use . . . the soundness of its overall design so it will stay on the job for years to come. On all these scores P&C Hack Saw Frames measure up. Handles are easy to grip, blades are easy to change—to adjust for regular, side or back cuts.

A TUBULAR FRAME HACKSAW

Here is a hacksaw that won't let blades wobble or bend. Lightweight yet exceptionally strong with tubular steel frame and die cast aluminum front end and handle. Extra blade storage space provided in the tubular part of the frame. Easily adjusted to use either 10" or 12" blades. Blade adjusts for angular cuts.

No.	Overall Length	Wt. Lbs.
1353	17"	1.00

B TUBULAR FRAME HACKSAW

A popular priced tubular hacksaw that sacrifices nothing in strength and ease of use. Handle is close to blade end for better balance and more cutting pressure. Frame will not twist. Always holds the blade tight. Accommodates both 10" and 12" blades. Blade storage provided in frame.

No.	Overall Length	Wt. Lbs.
1354	17"	1.3

C TUBULAR FRAME HACKSAW

Economy priced wobble-free frame is die-cast for extra strength, reinforced at all stress points. Easy on hands, handle is practically indestructible. Extra blade storage space in the tubular frame. Handles both 10" and 12" blades. Comes with 10" blade.

No.	Overall Length	Wt. Lbs.
1355	16"	1.0

D RIGID-FRAME HACKSAW

This is a hacksaw of conventional design intended for the heaviest use. No twist or warp in the frame of tough, tempered steel. Adjustable to take 10" or 12" blades and to make side or reverse cuts. Handles of molded plastic fit the hand for easy use.

No.	Overall Length	Wt. Lbs.
1361	17½"	1.90

E LOW CLEARANCE HACKSAW

Here is the steel-cutting version of the keyhole saw. Adjustable throat gives you cuts through 1" material or insertion into a 1" hole for any inside cut. Uses standard 10" blade. Solid steel backbone gives tremendous blade tension for easy cutting.

No.	Overall Length	Wt. Lbs.
1345	16½"	1.00

For best cutting results with P&C Hacksaws use P&C Hacksaw Blades. Two types to pick from in both 10" and 12" lengths and all popular teeth sizes. See page 24.

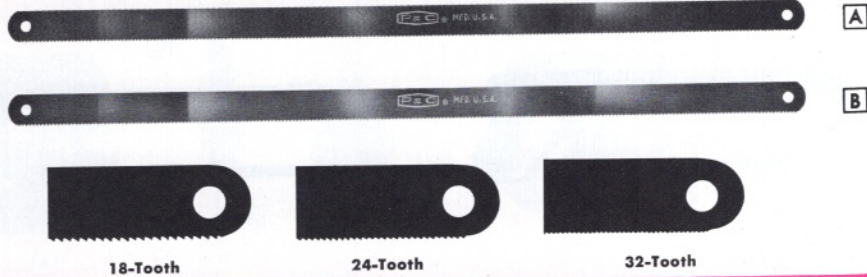
**A HACKSAW BLADES — BEST-TUF[®]**

You'll never find a finer, general-purpose hand hacksaw blade. Fabricated with years of saw making experience from patented special alloy steel. Teeth will not strip even when used on the lightest tubing or thinnest sheet metal.

No.	Length	Width	Teeth per In. of Blade	Wt. Lbs.
HB 1018-T	10"	½"	18	.04
HB 1024-T	10"	½"	24	.04
HB 1218-T	12"	½"	18	.05
HB 1224-T	12"	½"	24	.05
HB 1232-T	12"	½"	32	.05

18-tooth are straight set. 24 and 32-tooth are wavy set.

B HACKSAW BLADES — BEST-FLEX[®]

This is the blade to use when there is a tough cutting job to do and where breakage is a problem. Made of molybdenum high speed steel. Designed for high speed use and long wear. Unbreakable in use. Can be used to cut high alloy steels.

No.	Length	Width	Teeth per In. of Blade	Wt. Lbs.
HB 1018-F	10"	½"	18	.04
HB 1024-F	10"	½"	24	.04
HB 1218-F	12"	½"	18	.05
HB 1224-F	12"	½"	24	.05
HB 1232-F	12"	½"	32	.05

18-tooth blades have straight set. 24 and 32-tooth blades have wavy set.

18-Tooth recommended for general shop use on tool steel, iron pipe and light angle iron.

24-Tooth for cutting hard materials where the cross section is ⅙" or more.

32-Tooth for cutting stock up to ⅙" such as thin sheet metal, light tubing, BX.

BENCH VISES

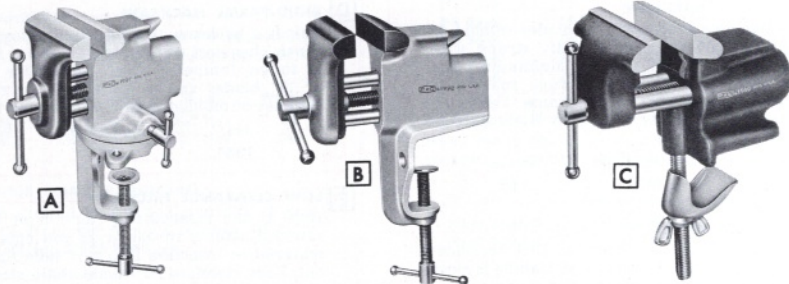
**A SWIVEL BENCH VISE**

Permits jaws to be swung to the angle best suited to the job at hand. Swivel clamping mechanism works smoothly and holds securely. Jaws are 2½" wide and open to 2¼".

No.	Description	Wt. Lbs.
1997	Swivel Bench Vise	5.50

B RIGID BENCH VISE

A strong, rigid vise that clamps firmly to the bench. Jaws open to 2¾" and are 2½" wide.

No.	Description	Wt. Lbs.
1998	Rigid Bench Vise	4.00

C PREMIER BENCH VISE

Big 3" jaws that open to 2¾". Parallel guide rods add strength and sturdiness plus keeping work from touching the screw. Has V-grooved jaws for holding rounds. Unbreakable ⅝" steel clamping stud and power-grip cantilever clamping foot fits vise to bench.

No.	Description	Wt. Lbs.
1999	Rigid Bench Vise	3.25

Jaws stay parallel on P&C Vises for a positive grip every time.

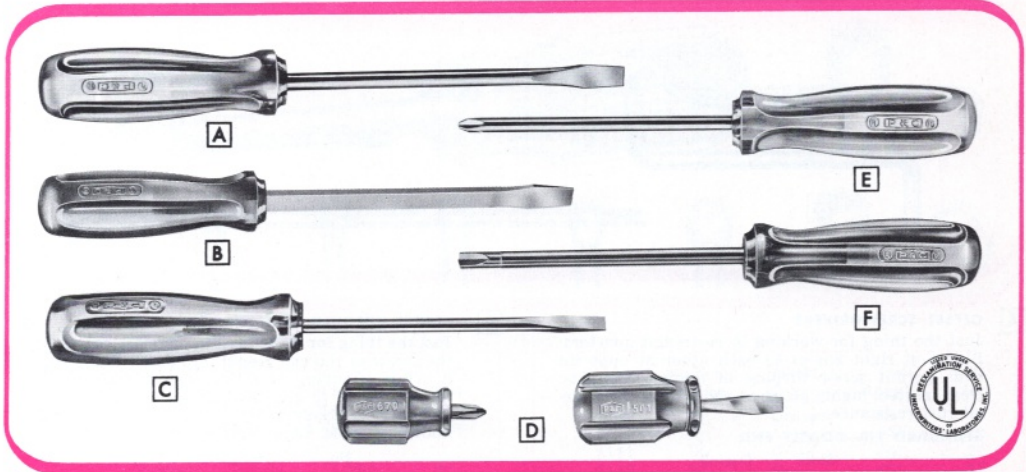

Blades are forged from toughened special alloy steel. Handles are clear shock-proof, acid-proof plastic or of special selected fine-grain hardwood and are shaped for best grip and no slip. Blades are fastened to handles with flanged end that will not loosen . . . we guarantee it.

A PLASTIC HANDLE—STANDARD TIP—ROUND SHANK

No.	Blade Diam.	Blade Length	Overall Length	Wt. Lbs.
402	1/8"	2 1/2"	5 1/4"	.05
404	1/8"	4 1/2"	7 1/4"	.06
504	3/16"	4"	7 1/2"	.10
508	3/16"	7 1/2"	11"	.13
634	1/4"	4"	8"	.17
736	3/16"	6"	10 1/2"	.30
740	3/16"	10"	14 1/2"	.39
838	3/8"	8"	13"	.47

B PLASTIC HANDLE—STANDARD TIP—SQUARE SHANK

No.	Blade Diam.	Blade Length	Overall Length	Wt. Lbs.
442	1/8"	2 1/2"	5 1/4"	.04
542	3/16"	1 1/2"	4 1/4"	.06
544	3/16"	4"	7 1/2"	.11
548	3/16"	7 1/2"	11"	.15
603	1/4"	3"	6 3/4"	.13
604	1/4"	4"	8"	.15
609	1/4"	9"	13"	.25
705	5/16"	5"	9 3/8"	.31
706	5/16"	6"	10 1/2"	.33
710	3/16"	10"	14 1/2"	.43
808	3/8"	8"	13"	.55
810	3/8"	10"	15"	.62
812	3/8"	12"	17"	.90
816	3/8"	16"	23"	1.05

C PLASTIC HANDLE—CABINET TIP—ROUND SHANK

No.	Blade Diam.	Blade Length	Overall Length	Wt. Lbs.
462	1/8"	2 1/2"	5 1/4"	.05
464	1/8"	4"	7"	.06
466	1/8"	6"	8 3/4"	.06
562	3/16"	3"	6 3/4"	.10
564	3/16"	4"	7 1/2"	.10
565	3/16"	5"	8 3/8"	.13
566	3/16"	6"	9 1/2"	.12
568	3/16"	8"	11 1/2"	.13
669	1/4"	10"	14"	.24

D STUBBY SCREWDRIVERS

No.	Type of Tip	Overall Length	Wt. Lbs.
501	Standard	3"	.07
601	Standard	3 3/8"	.13
670	Phillips No. 2	2 1/2"	.08
690	Reed & Prince	2 3/8"	.07

E PLASTIC HANDLE—CROSS SLOT SCREWDRIVERS

No.	Phillips Blade Size	Blade Length	Overall Length	Wt. Lbs.
473	0	2 1/4"	5"	.05
573	1	3"	6 1/2"	.10
674	2	4"	8"	.15
776	3	6"	10 1/2"	.28
878	4	8 1/2"	13 1/2"	.50

REED & PRINCE

No.	Blade Diam.	Blade Length	Overall Length	Wt. Lbs.
592	3/8"	3"	6 3/8"	.09
693	1/4"	4"	8"	.17
794	5/16"	6"	10 3/8"	.30

F CLUTCH HEAD

No.	Bit Size	Blade Length	Overall Length	Wt. Lbs.
483	5/32"	3 3/8"	7 3/8"	.12
584	3/16"	3 3/8"	7 3/8"	.12
685	1/4"	4 7/8"	8 7/8"	.18
786	5/16"	4 7/8"	9 3/8"	.28

ALL PURPOSE SCREWDRIVER SET
Set includes one each of P&C numbers 544, 601, 604, 706, 808, 812. Kit is vinyl plastic.

No. 500-A
Screwdriver Set
Wt. 2.30 lbs.



No. 2430
Roll up kit only
Wt. .04 lbs.

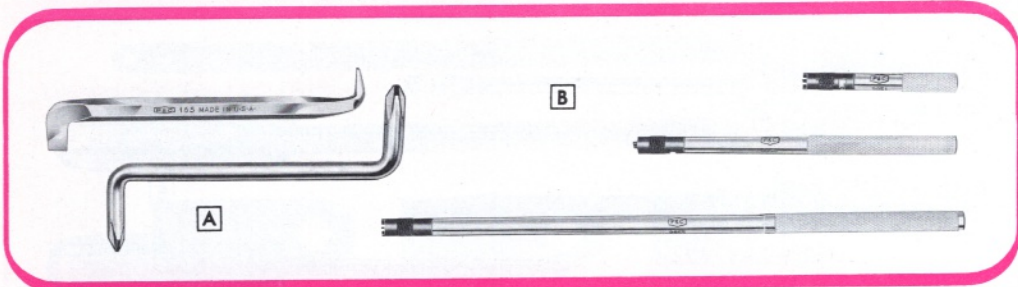

A OFFSET SCREWDRIVERS

Just the thing for working in restricted quarters. Blades at right angles to each other at opposite ends permit screw turning in minimum radius. Heat treated, highly polished and treated for overall rust resistance.

STANDARD TIP—DOUBLE END

No.	Stock Size	Overall Length	Wt. Lbs.
163	1/4"	3"	.05
164	3/8"	4 3/4"	.07
165	5/16"	5"	.11
166	3/8"	6 1/8"	.19

PHILLIPS CROSS-SLOT TIP — DOUBLE END

No.	Phillips Blade Size	Overall Length	Wt. Lbs.
152	1 & 2	4 3/4"	.19
153	3 & 4	5 1/2"	.31

B SCREW HOLDING SCREWDRIVERS

Just the thing for those hard to get at places. Holds the screw so you can feed it into position and start it before changing over to a regular screwdriver. Spring loaded to give 5-9 inch-pounds of pressure in the slot. Easily released with a twist of the knurled handle. Light weight and easy to use.

No.	Length	Wt. Lbs.
9851	2 1/2"	.05
9853	5"	.10
9855	9"	.12

SOCKET SCREWDRIVERS

You can often get the job done faster and easier with a Socket Screwdriver. See pages 31 through 37.

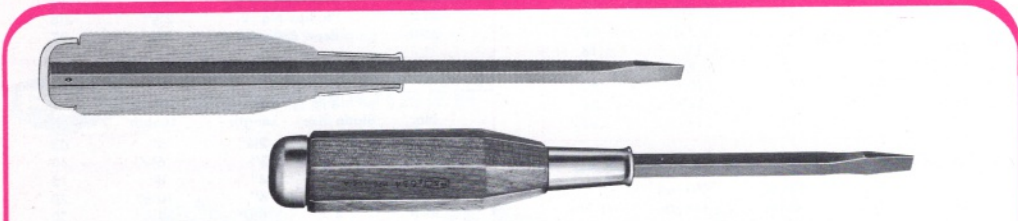

WOOD HANDLE SCREWDRIVERS

P&C Wood Handle Screwdrivers are designed for the toughest of usage. Blade extends the full length of the clear birch handle. A steel pin through the steel handle cap, then the handle and finally the blade extension, welds them all into a solid unit. In addition a steel ferrule protects the blade end of the handle.

STANDARD TIP — SQUARE SHANK

No.	Stock Size	Blade Length	Overall Length	Wt. Lbs.
452	1/8"	2 1/2"	5 3/4"	.06
551	3/16"	1 1/2"	4 1/2"	.10
553	3/16"	2 1/2"	6 5/8"	.12
554	3/16"	4"	8 7/8"	.16
559	3/16"	9"	13 1/4"	.17
654	1/4"	4"	9 1/8"	.22
660	1/4"	9 1/2"	14 1/2"	.30

STANDARD TIP — SQUARE SHANK (Cont'd)

No.	Stock Size	Blade Length	Overall Length	Wt. Lbs.
752	5/16"	1 1/4"	6"	.30
756	5/16"	6"	12"	.42
760	5/16"	10"	16"	.50
858	3/8"	8"	14 3/16"	.78
862	3/8"	12"	18 3/16"	.97
964	7/16"	13 3/8"	22 1/16"	1.55

PHILLIPS CROSS SLOT

No.	Phillips Blade Size	Blade Length	Overall Length	Wt. Lbs.
523	1	3"	6 1/4"	.08
624	2	4"	8 7/8"	.18
726	3	6"	12"	.30
828	4	8"	14 1/2"	.52

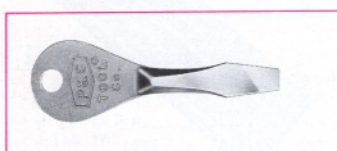

KEY RING SCREWDRIVER

Handier than a pocket knife. Fits on key ring or watch chain. Use it to open cans, open doors, emergency repairs. Makes the perfect small gift or business reminder. A good conversation starter.

No.	Bit Width	Length	Wt. Lbs.
400	3/16"	2 1/4"	.015

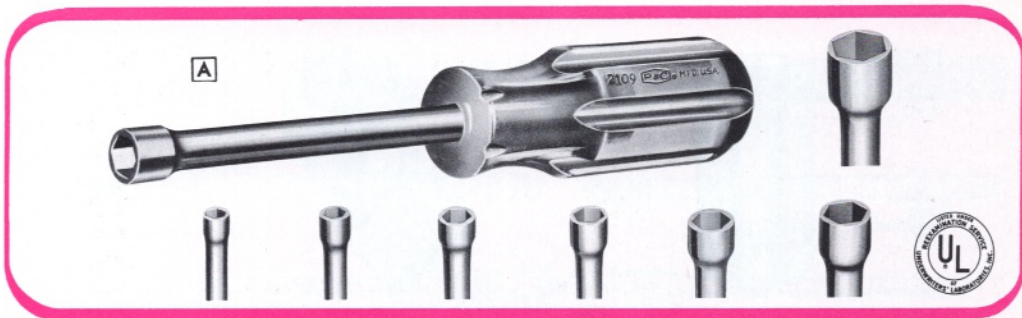

A HEX NUT DRIVERS

The handiest tool you'll ever use on small nuts and in confined places. A must on electronic equipment, instruments, radio and ignition work. Easy-on-the-hand fluted handles are color coded by size, are fire and shock resistant.

No.	Nominal Opening	Handle Color	Tool Length	Wt. Lbs.
2109	$\frac{3}{32}$ "	Orange	6 $\frac{1}{8}$ "	.16
2110	$\frac{1}{16}$ "	Amber	6 $\frac{1}{8}$ "	.22
2111	$\frac{1}{8}$ "	Green	6 $\frac{1}{8}$ "	.22
2112	$\frac{3}{16}$ "	Blue	6 $\frac{1}{8}$ "	.22
2114	$\frac{1}{4}$ "	Brown	7 $\frac{3}{16}$ "	.30
2116	$\frac{1}{2}$ "	Red	7 $\frac{3}{16}$ "	.30
2118	$\frac{5}{16}$ "	Orange	7 $\frac{3}{16}$ "	.33
2120	$\frac{3}{8}$ "	Amber	7 $\frac{3}{16}$ "	.33

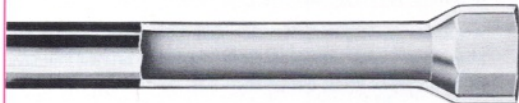

You get greater convenience and more wear from P&C Hex Drivers. Special heat treated shaft is hollow for lighter weight and to allow follow-through tightening on long bolts. Drive openings are precision formed to fit tightly for positive tightening.

STEEL LETTERS AND FIGURES

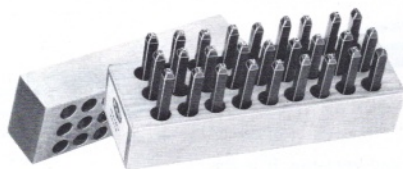

A

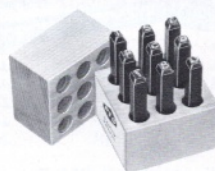

B

A STEEL LETTERS

The positive way to get permanent tool and part identification on all metals. A very readable gothic face that has been specially hardened and tempered for long life. Six letter sizes to choose from. Sets include all letters and a period.

No.	Character Height	Stock Size	Set Wt. Lbs.
1541	$\frac{1}{16}$ "	$\frac{1}{4}$ " x 2 $\frac{3}{8}$ "	1.38
1542	$\frac{3}{32}$ "	$\frac{1}{4}$ " x 2 $\frac{3}{8}$ "	1.38
1543	$\frac{1}{8}$ "	$\frac{1}{4}$ " x 2 $\frac{3}{8}$ "	1.38
1544	$\frac{3}{16}$ "	$\frac{3}{8}$ " x 2 $\frac{1}{2}$ "	2.50
1545	$\frac{1}{4}$ "	$\frac{3}{8}$ " x 2 $\frac{1}{2}$ "	3.38
1546	$\frac{3}{8}$ "	$\frac{1}{2}$ " x 2 $\frac{3}{8}$ "	6.50

B STEEL FIGURES

Make the job of serial numbering easy and quick. Also permanent. Made of hardened tool steel with deep-etched faces that will last for years. Set includes characters 0 to 8, the 6 doubling for the 9.

No.	Character Height	Stock Size	Set Wt. Lbs.
1551	$\frac{1}{16}$ "	$\frac{1}{4}$ " x 2 $\frac{3}{8}$ "	.50
1552	$\frac{3}{32}$ "	$\frac{1}{4}$ " x 2 $\frac{3}{8}$ "	.50
1553	$\frac{1}{8}$ "	$\frac{1}{4}$ " x 2 $\frac{3}{8}$ "	.50
1554	$\frac{3}{16}$ "	$\frac{3}{8}$ " x 2 $\frac{1}{2}$ "	.88
1555	$\frac{1}{4}$ "	$\frac{3}{8}$ " x 2 $\frac{1}{2}$ "	1.13
1556	$\frac{3}{8}$ "	$\frac{1}{2}$ " x 2 $\frac{3}{8}$ "	2.13

POSITIVE
NUT FIT

THIN
WALL



PLAIN
SIZE
MARKING

CHAMFERED
EDGE

HOT BROACHED
TO CLOSE
TOLERANCE

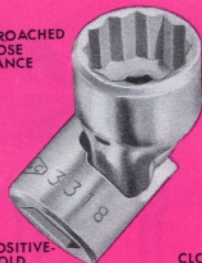

PIN STAYS
PUT

FREE
WORKING
JOINT

SOCKET
OPENING
TYPES



6 PT



8 PT



12 PT

BEAUTIFUL
CHROME
FINISH

DETENT BALL
POSITIVE MARKED

POSITIVE-
HOLD
DETENT BALL

CLOSE FIT
SQUARE DRIVE

No finer sockets, socket handles and attachments are made than those carrying the P&C label. Each is designed with care to get the job done with greatest ease and efficiency. They are made from special alloy steel, machined to perfection, clearly marked for speedier use and beautifully finished in high-polish chrome.

P&C Sockets have strong, light, thin walls to give remarkable toughness along with small size to go into tight places. Chamfered openings slip on nuts and bolts easily. Detent ball position is clearly marked as is the size of every socket.

P&C Handles give maximum utility regardless of the type. Ratchet handles work smoothly with minimum reverse

drag and completely trouble-free mechanisms. Spinner and speeder handles fit the palm of the hand for greater use comfort.

P&C Attachments make quick work of many tightening jobs. Universal Joints and Universal Sockets work smoothly even at extreme angles. Socket screwdrivers give a positive fit to prevent slot damage. Ratcheters, for converting non-ratcheting handles into a ratcheting device, add to the convenience of many tools and are designed to be easily reversed and smooth to operate.

Available in 1/4", 3/8", 1/2", 3/4" and 1" square drive sizes plus power and impact styles... there is a P&C Socket or attachment to fit every need.

TORQUE-LIMITING WRENCHES

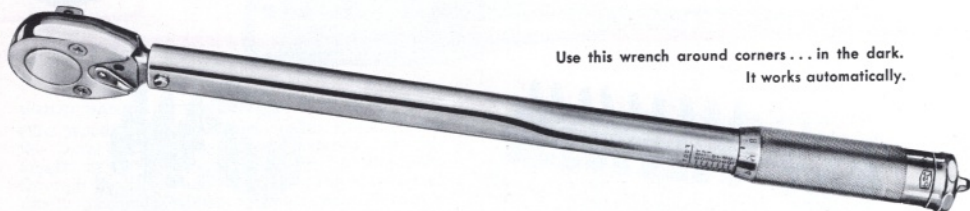

Use this wrench around corners... in the dark.
It works automatically.

The simple, easy-to-use P&C Torquer is foolproof, safe and versatile. It is the fastest torquer on the market. It gives positive torque-limiting action every time. There are no sounds to listen for and no dials to watch. It resets itself automatically. The all steel construction assures years of trouble-free use. The streamlined design lets it fit into tight spots. The automatic "clicking" signal "talks" to you through the handle. Knurled handle sets easily to the precise ft./lb. or in./lb. torque with easy to read micrometer type settings. Built-in lock holds setting during use. Eight models to pick from in plain or ratchet head.

U.S. Patent No. 3,140,623

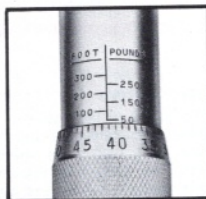

No.	Drive Size	Type Head	Capacity	Overall Length	Wt. Lbs.
6306	3/8"	Ratchet	0-80 Ft./lb.	14"	1.44
6308	1/2"	Ratchet	0-80 Ft./lb.	14"	1.50
6315	1/2"	Plain	10-150 Ft./lb.	17 1/2"	2.31
6316	1/2"	Ratchet	10-150 Ft./lb.	17 3/4"	2.50
6317	3/4"	Plain	100-500 Ft./lb.	37"	8.75
6318	3/4"	Ratchet	50-300 Ft./lb.	33"	7.56
6361	1/4"	Plain	0-150 In./lb.	9 1/4"	.94
6371	3/4"	Plain	1200-6000 In./lb.	37"	8.75

1/4" DRIVE SOCKETS, HANDLES AND ATTACHMENTS



31

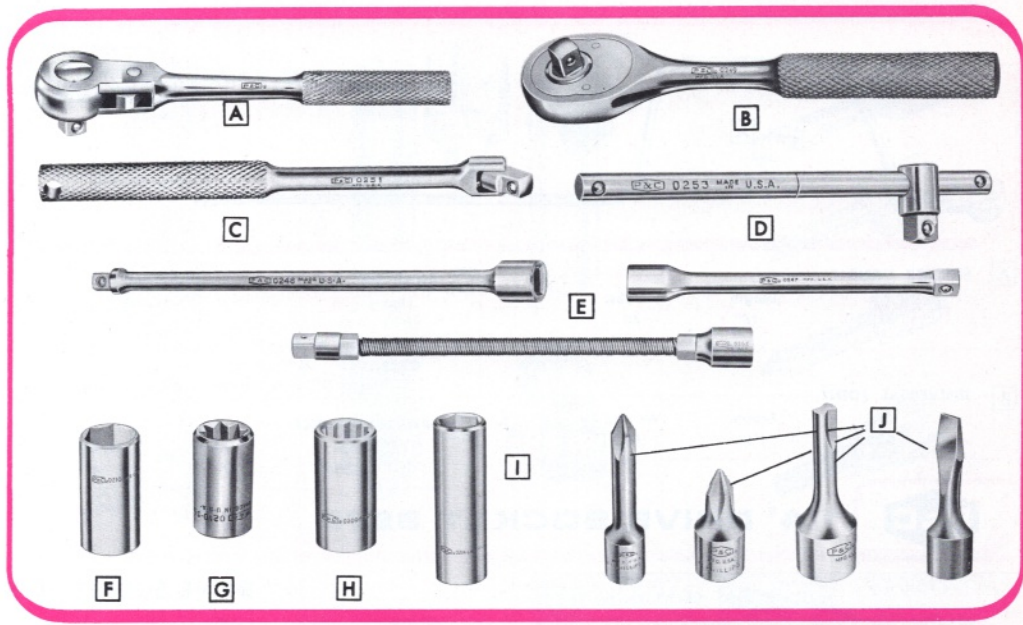

A REVERSIBLE RATCHET—SMALL HEAD

No.	Length	Wt. Lbs.
0246*	4 1/2"	.18

B REVERSIBLE RATCHET—CLOSED HEAD

No.	Length	Wt. Lbs.
0249	5"	.21

C HINGE HANDLE

No.	Length	Wt. Lbs.
0251	5 1/2"	.16

D SLIDING-T HANDLE

No.	Length	Wt. Lbs.
0253	4 1/2"	.08

E EXTENSIONS

No.	Length	Wt. Lbs.
0247	3 1/2"	.06
0248	6"	.10
0262	2"	.04
0263	14"	.15
0265	6" (Flexible)	.08

F 6-POINT EXTRA DEEP SOCKETS (All 2" Length)

No.	Size	Wt. Lbs.
0206	3/16"	.02
0207	7/32"	.02
0208	1/4"	.02
0209	9/32"	.03
0210	5/16"	.03
0211	11/32"	.03
0212	3/8"	.04
0214	7/16"	.05

G 8-POINT SOCKETS (All 7/8" Length)

No.	Size	Wt. Lbs.
0208-S	1/4"	.02
0210-S	5/16"	.04
0212-S	3/8"	.05

H 12-POINT SOCKETS (All 7/8" Length)

No.	Size	Wt. Lbs.
0207-T	7/32"	.02
0208-T	1/4"	.02
0209-T	9/32"	.02
0210-T	5/16"	.02
0211-T	11/32"	.03
0212-T	3/8"	.03
0214-T	7/16"	.04
0216-T	1/2"	.05

I 6-POINT EXTRA DEEP SOCKETS (All 2" Length)

No.	Size	Wt. Lbs.
0208-L	1/4"	.04
0209-L	9/32"	.04
0210-L	5/16"	.04
0211-L	11/32"	.07
0212-L	3/8"	.09
0214-L	7/16"	.11

J SCREWDRIVER SOCKETS

No.	Bit Size	Length	Wt. Lbs.
0235	3/32" Clutch Head	1 1/2"	.04
0236	7/16" Clutch Head	1 1/2"	.04
0237	Phillips No. 1	1"	.02
0237-L	Phillips No. 1	2"	.03
0238	Phillips No. 2	1"	.02
0238-L	Phillips No. 2	2"	.03
0244	3/16" x .030"	1 3/4"	.03
0245	1/4" x .030"	3"	.06
6535	Two-Prong Special Driver for Chev. Distributor	1 1/8"	.02

*SEE PRICE LIST FOR REPLACEMENT PARTS

P&C Sockets are clearly size marked for ease and convenience in use.



1/4" DRIVE SOCKETS, HANDLES AND ATTACHMENTS

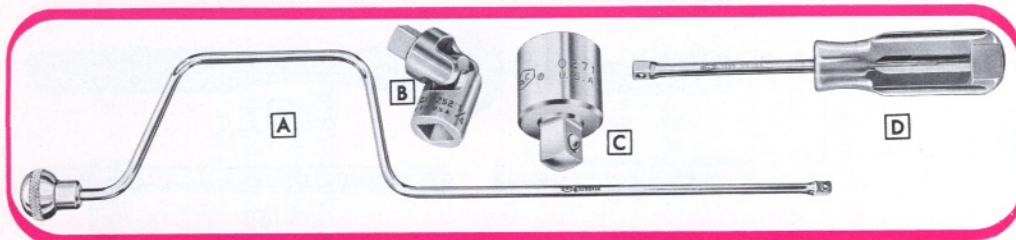

A SPEEDER HANDLE		
No.	Length	Wt. Lbs.
0280	16"	.40

B UNIVERSAL JOINT		
No.	Length	Wt. Lbs.
0252	1 1/4"	.03

C ADAPTORS		
No.	Length	Wt. Lbs.
0271	3/8" F x 1/4" M (Adapts 3/8" drive handles to 1/4" drive sockets)	1 5/16" .03
0272	1/4" F x 3/8" M (Adapts 1/4" drive handles to 3/8" drive sockets)	1 5/16" .05

D SPINNER HANDLE		
No.	Length	Wt. Lbs.
0259	6"	.14

1/4" DRIVE SOCKET SETS



Set No. 0200C



Set No. 0200F

1/4" DRIVE SOCKET SETS

No.	Description	Set No.	Set No.	Set No.	Set No.
		0200A	0200C	0200D	0200F
0206	Regular Socket, 6 pt. 3/16"	X	X
0207	Regular Socket, 6 pt. 1/8"	X	X	X	X
0208	Regular Socket, 6 pt. 1/4"	X	X	X	X
0209	Regular Socket, 6 pt. 5/32"	X	X	X	X
0210	Regular Socket, 6 pt. 3/16"	X	X	X	X
0211	Regular Socket, 6 pt. 11/32"	X	X	X	X
0212	Regular Socket, 6 pt. 3/8"	X	X	X	X
0214	Regular Socket, 6 pt. 7/16"	X	X	X	X
0216-T	Regular Socket, 12 pt. 1/2"	X	..
0208-L	Deep Socket, 6 pt. 1/4"	X	..
0209-L	Deep Socket, 6 pt. 5/32"	X	..
0210-L	Deep Socket, 6 pt. 3/16"	X	..
0211-L	Deep Socket, 6 pt. 11/32"	X	..
0212-L	Deep Socket, 6 pt. 3/8"	X	..
0214-L	Deep Socket, 6 pt. 7/16"	X	..
0208-5	Regular Socket, 8 pt. 1/4"	X	X	X	X
0210-5	Regular Socket, 8 pt. 3/16"	X	X	X	X
0212-5	Regular Socket, 8 pt. 3/8"	X	X
0237	Phillips No. 1 Socket Screwdriver	X	..
0238	Phillips No. 2 Socket Screwdriver	X	..
0244	Screwdriver, 3/16" x .030"	X	..
0245	Screwdriver, 1/4" x .030"	X	..
0246	Reversible Ratchet	..	X	X	X
0247	Extension, 3 1/2"	X	X
0248	Extension, 6"	X	X
0251	Hinge Handle, 5 1/2"	X	X
0252	Universal Joint, 1 1/4"	X	..
0253	Sliding T-Handle, 4 1/2"	X	X	X	..
0259	Spinner Handle, 6"	X	X	X	..
0265	Flexible Extension, 6"	X	..
4795-P	Molded Plastic Box of Polypropylene, 6 3/4" x 3" x 1 1/8"	X	X	..	X
4796	Metal Box, 12" x 3 1/2" x 1 1/8"	X	..
4795	Metal Box, 6 3/4" x 3" x 1 1/4"	X	..

To get above sets in metal instead of lifetime plastic, order 0200AM, 0200CM, 0200FM.

Weight of sets in plastic box 1.00 1.16 2.93 1.90

3/8" DRIVE SOCKETS, HANDLES AND ATTACHMENTS

P&C

33

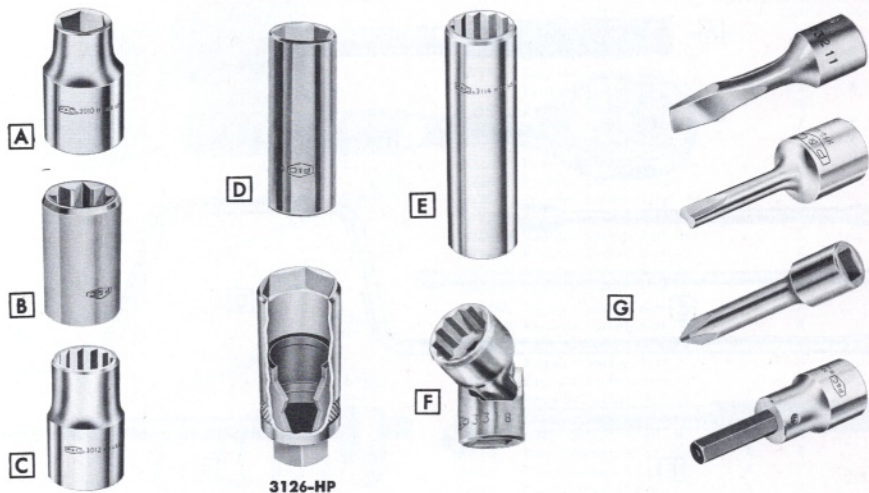

3126-HP

A 6-POINT SOCKETS

No.	Opening Size	Length	Wt. Lbs.
3010-H	5/16"	1"	.04
3012-H	3/8"	1"	.04
3014-H	7/16"	1"	.04
3016-H	1/2"	1"	.04
3018-H	9/16"	1"	.05
3020-H	5/8"	1"	.07
3022-H	11/16"	1 1/8"	.10

B 8-POINT SOCKETS

No.	Opening Size	Length	Wt. Lbs.
3008-S	1/4"	1"	.04
3009-S*	5/32"	1 3/8"	.04
3010-S	5/16"	1 1/8"	.04
3012-S	3/8"	1 1/8"	.06
3014-S	7/16"	1 1/8"	.07
3016-S	1/2"	1 1/8"	.10

*Special 4-point socket fits drain plug on Dynaflo torque converter.

C 12-POINT SOCKETS

No.	Opening Size	Length	Wt. Lbs.
3010	5/16"	1"	.04
3012	3/8"	1"	.04
3014	7/16"	1"	.04
3016	1/2"	1"	.04
3018	9/16"	1"	.05
3019	15/32"	1"	.06
3020	5/8"	1"	.07
3022	11/16"	1 1/8"	.10
3024	3/4"	1 1/8"	.13
3026	13/16"	1 3/8"	.15
3028	7/8"	1 3/8"	.17

D 6-POINT EXTRA DEEP SOCKETS

No.	Opening Size	Length	Wt. Lbs.
3112-H	3/8"	2 1/8"	.10
3114-H	7/16"	2 1/8"	.10
3116-H	1/2"	2 1/8"	.12
3118-H	9/16"	2 1/8"	.14
3120-H	5/8"	2 1/8"	.16
3122-H	11/16"	2 3/8"	.21
3126-HP*	1 1/16"	2 1/2"	.28

*Special Spark Plug Socket with Neoprene Insert. Hex head permits turning with a wrench.

E 12-POINT EXTRA DEEP SOCKETS

No.	Opening Size	Length	Wt. Lbs.
3112	3/8"	2 1/8"	.10
3114	7/16"	2 1/8"	.10
3116	1/2"	2 1/8"	.10
3118	9/16"	2 1/8"	.12
3120	5/8"	2 1/8"	.15
3122	11/16"	2 1/8"	.18
3124	3/4"	2 1/8"	.20
3126	13/16"	2 3/8"	.28
3128	7/8"	2 3/8"	.28

F 12-POINT UNIVERSAL SOCKETS

No.	Opening Size	Length	Wt. Lbs.
3312	3/8"	1 1/2"	.10
3314	7/16"	1 1/2"	.10
3316	1/2"	1 1/2"	.10
3318	9/16"	1 1/2"	.11
3320	5/8"	1 3/4"	.12
3322	11/16"	1 7/8"	.13
3324	3/4"	2"	.15

G SCREWDRIVER SOCKETS

No.	Description	Size	Length	Wt. Lbs.
3075	Regular Type	11/16"	1"	.08
3211	Regular Type	3/16"	2 1/2"	.08
3235	Clutch Head	1/4"	2"	.08
3236	Clutch Head	5/16"	2"	.08
3237	Clutch Head	3/8"	2"	.08
3241	Phillips	No. 2	1 5/8"	.05
3242	Phillips	No. 3	1 3/8"	.05
3243	Phillips	No. 4	1 3/8"	.06
3246	Regular Type	1/4"	1 7/8"	.06
3290-1/8"	Hollow Head Screws	1/8"	2"	.05
3290-3/32"	Hollow Head Screws	3/32"	2"	.06
3290-1/16"	Hollow Head Screws	1/16"	2"	.06
3290-3/16" L*	Hollow Head Screws	3/16"	3"	.07
3290-7/32"	Hollow Head Screws	7/32"	2 1/8"	.08
3290-1/4" †	Hollow Head Screws	1/4"	2 1/8"	.09
3290-1/4" †	Hollow Head Screws	1/4"	2 3/8"	.10
3290-5/16"	Hollow Head Screws	5/16"	2 1/4"	.11
3290-3/8"	Hollow Head Screws	3/8"	2 1/4"	.13
3290-3/8" L ‡	Hollow Head Screws	3/8"	3 1/8"	.14

*For GM Automatic Transmissions.

†For Chevrolet Camber Adjustment.

‡For Ford brakes and Ford, Edsel, Mercury differential filler plugs.

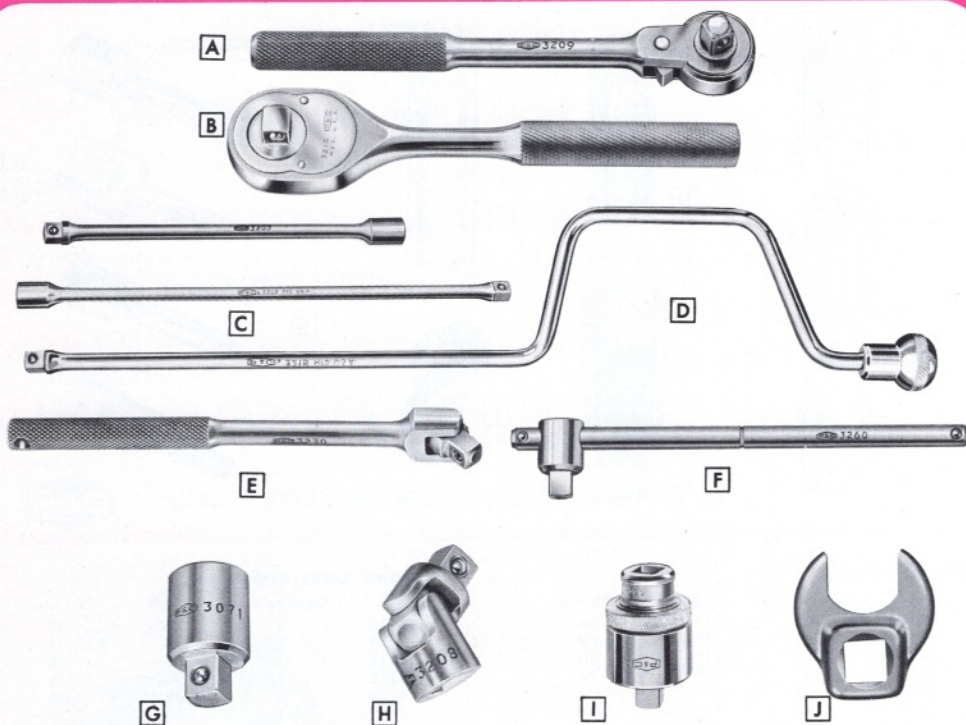

A REVERSIBLE RATCHET—SMALL HEAD
Small, narrow-head design. Exposed reversing dog.

No.	Length	Wt. Lbs.
3209*	7 1/4"	.50

B REVERSIBLE RATCHET—CLOSED HEAD
Completely enclosed head. Keeps ratcheting and reversing mechanism free of dirt.

No.	Length	Wt. Lbs.
3210*	7"	.55

C EXTENSIONS

No.	Length	Wt. Lbs.
3201	1 3/4"	.09
3202	3 1/2"	.13
3203	8"	.25
3205	12 1/2"	.38
3206	18 1/2"	.55

D SPEEDER HANDLE

No.	Length	Wt. Lbs.
3215	18"	.83

E HINGE HANDLE

No.	Length	Wt. Lbs.
3230	7 1/2"	.35
3231	12"	.83

F SLIDING T-HANDLE

No.	Length	Wt. Lbs.
3260	7 1/2"	.35

G ADAPTORS

No.	Length	Wt. Lbs.
3071	1 3/8"	.13
(Adapts 1/2" F x 3/8" M handles to 3/8" drive sockets)		
3072	1 1/8"	.10
(Adapts 3/8" F handles to 1/2" drive sockets)		

H UNIVERSAL JOINT

No.	Length	Wt. Lbs.
3208	1 3/4"	.10

I RATCHETOR
Converts any non-ratcheting handle into a reversible ratcheting device.

No.	Length	Wt. Lbs.
3247	2"	.33

J CROW FOOT WRENCHES

No.	Opening	Length	Wt. Lbs.
3412	3/8"	1 1/8"	.05
3414	7/16"	1 1/8"	.05
3416	1/2"	1 1/8"	.05
3418	9/16"	1 3/8"	.08
3420	5/8"	1 3/8"	.08
3422	11/16"	1 3/8"	.08
3424	3/4"	1 3/8"	.14

*See price list for individual replacement parts.

3/8" DRIVE SOCKET SETS

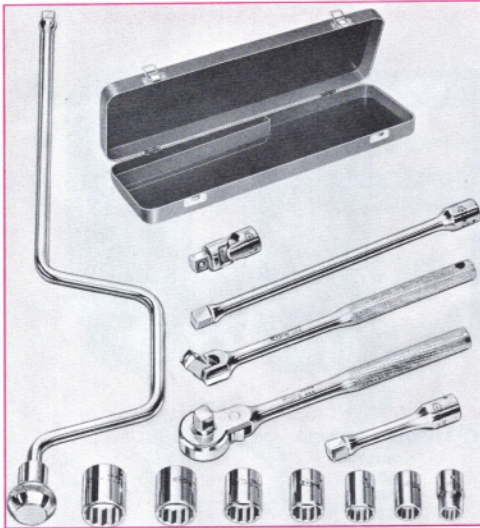

Set No. 3000K

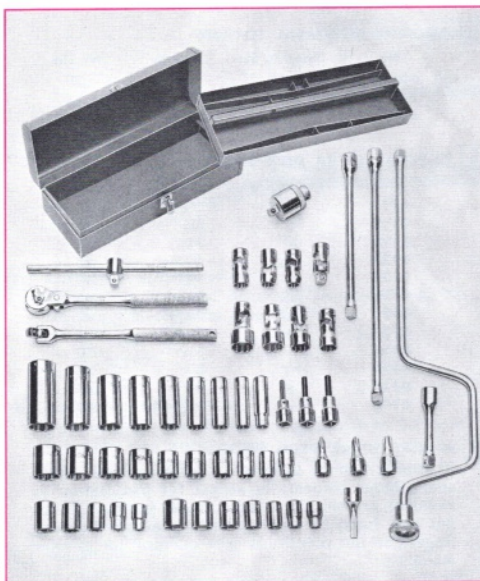

Set No. 3000G

No.	Description	Set No.	Set No.	Set No.	Set No.
		3100A	3000G	3000K	3000NR
3012	Regular Socket, 12-pt. 3/8"	..	X	X	X
3014	Regular Socket, 12-pt. 7/16"	..	X	X	X
3016	Regular Socket, 12-pt. 1/2"	..	X	X	X
3018	Regular Socket, 12-pt. 5/8"	..	X	X	X
3019	Regular Socket, 12-pt. 15/32"	..	X
3020	Regular Socket, 12-pt. 5/8"	..	X	X	X
3022	Regular Socket, 12-pt. 11/16"	..	X	X	X
3024	Regular Socket, 12-pt. 3/4"	..	X	X	X
3026	Regular Socket, 12-pt. 13/16"	..	X
3028	Regular Socket, 12-pt. 7/8"	..	X
3010-H	Regular Socket, 6-pt. 3/8"	..	X
3012-H	Regular Socket, 6-pt. 7/16"	..	X
3014-H	Regular Socket, 6-pt. 1/2"	..	X
3016-H	Regular Socket, 6-pt. 5/8"	..	X
3018-H	Regular Socket, 6-pt. 3/4"	..	X
3020-H	Regular Socket, 6-pt. 7/8"	..	X
3022-H	Regular Socket, 6-pt. 15/16"	..	X
3008-5	Regular Socket, 8-pt. 1/4"	..	X
3010-5	Regular Socket, 8-pt. 3/8"	..	X
3012-5	Regular Socket, 8-pt. 1/2"	..	X
3014-5	Regular Socket, 8-pt. 3/4"	..	X
3016-5	Regular Socket, 8-pt. 7/8"	..	X
3112	Deep Socket, 12-pt. 3/8"	X	X
3114	Deep Socket, 12-pt. 7/16"	X	X
3116	Deep Socket, 12-pt. 1/2"	X	X
3118	Deep Socket, 12-pt. 5/8"	X	X
3120	Deep Socket, 12-pt. 3/4"	X	X
3122	Deep Socket, 12-pt. 7/8"	X	X
3124	Deep Socket, 12-pt. 15/16"	X	X
3126	Deep Socket, 12-pt. 1 1/16"	X	X
3128	Deep Socket, 12-pt. 1 1/8"	X	X
5096	Metal Tray	X
3202	Extension, 3 1/2"	..	X	X	X
3203	Extension, 8"	..	X	X	..
3205	Extension, 12 1/2"	..	X
3208	Universal Joint, 1 3/4"	..	X	X	..
3209	Reversible Ratchet, 7 1/4"	..	X	X	X
3215	Speeder Handle	..	X	X	..
3230	Hinge Handle	..	X	X	X
3241	No. 2 Phillips Screwdriver	..	X
3242	No. 3 Phillips Screwdriver	..	X
3243	No. 4 Phillips Screwdriver	..	X
3246	Socket Screwdriver, 1/4" x .030"	..	X
3247	Ratchet, 2"	..	X
3260	Sliding T-Handle	..	X
3290-3/16"	Hollow Hd. Screw Socket	..	X
3290-1/8"	Hollow Hd. Screw Socket	..	X
3290-1/4"	Hollow Hd. Screw Socket	..	X
3312	Universal Socket, 12-pt. 3/8"	..	X
3314	Universal Socket, 12-pt. 7/16"	..	X
3316	Universal Socket, 12-pt. 1/2"	..	X
3318	Universal Socket, 12-pt. 5/8"	..	X
3320	Universal Socket, 12-pt. 3/4"	..	X
3322	Universal Socket, 12-pt. 7/8"	..	X
3324	Universal Socket, 12-pt. 1 1/8"	..	X
5295	Metal Box	X	X
5296	Metal Box	X	..

Wt. Lbs. 2.02 17.50 4.90 3.70

Note: To order set 3000K without box order No. 3000KK.
To order set 3000G without box order No. 3000GG.

3000-A HOLLOW HEAD SCREW SOCKET SET

No.	Description
3290-1/8"	3/8" drive, 1/8" bit size
3290-3/32"	3/8" drive, 3/32" bit size
3290-1/16"	3/8" drive, 1/16" bit size
3290-1/32"	3/8" drive, 1/32" bit size
3290-1/4"	3/8" drive, 1/4" bit size
3290-3/16"	3/8" drive, 3/16" bit size
3290-3/8"	3/8" drive, 3/8" bit size
6290-1/2"	1/2" drive, 1/2" bit size
6290-3/16"	1/2" drive, 3/16" bit size
6290-3/8"	1/2" drive, 3/8" bit size
4997	Metal Tray



Set No. 3000A



Wt. Lbs. 2.40





A



C



E



F

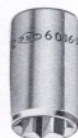

B



D

A 6-POINT SOCKETS

No.	Opening Size	Length	Wt. Lbs.
6012-H	3/8"	1 3/8"	.09
6014-H	7/16"	1 3/8"	.10
6016-H	1/2"	1 3/8"	.10
6018-H	9/16"	1 3/8"	.10
6020-H	5/8"	1 3/8"	.11
6022-H	11/16"	1 3/8"	.12
6024-H	3/4"	1 3/8"	.13

B 8-POINT SOCKETS

No.	Opening Size	Length	Wt. Lbs.
6012-S	3/8"	1 3/8"	.13
6014-S	7/16"	1 3/8"	.13
6016-S	1/2"	1 3/8"	.13
6018-S	9/16"	1 3/8"	.18
6020-S	5/8"	1 7/8"	.18
6022-S	11/16"	1 1/2"	.25
6024-S	3/4"	1 3/8"	.36
6026-S	13/16"	1 3/8"	.39
6028-S	7/8"	1 3/8"	.45
6032-S	1"	1 3/4"	.76

C 12-POINT SOCKETS

No.	Opening Size	Length	Wt. Lbs.
6012	3/8"	1 3/8"	.10
6014	7/16"	1 3/8"	.10
6016	1/2"	1 3/8"	.10
6018	9/16"	1 3/8"	.10
6019	19/32"	1 3/8"	.13
6020	5/8"	1 3/8"	.13
6021	21/32"	1 3/8"	.13
6022	11/16"	1 3/8"	.13
6024	3/4"	1 3/8"	.15
6025	25/32"	1 3/8"	.18
6026	13/16"	1 3/8"	.20
6028	7/8"	1 3/8"	.23
6029	29/32"	1 3/8"	.25
6030	15/16"	1 1/2"	.28

C 12-POINT SOCKETS—Continued

6031	31/32"	1 1/2"	.28
6032	1"	1 1/2"	.33
6034	1 1/16"	1 3/8"	.38
6036	1 1/8"	1 3/8"	.40
6038	1 3/8"	1 1/2"	.45
6040	1 1/4"	1 3/4"	.65

D 12-POINT UNIVERSAL SOCKETS

No.	Opening Size	Length	Wt. Lbs.
6016-K	1/2"	2 5/16"	.25
6018-K	9/16"	2 1/16"	.24
6020-K	5/8"	2 5/16"	.25

E 12-POINT EXTRA DEEP SOCKETS

No.	Opening Size	Length	Wt. Lbs.
6116	1/2"	3 1/4"	.23
6118	9/16"	3 1/4"	.23
6120	5/8"	3 1/4"	.23
6122	11/16"	3 1/4"	.25
6124	3/4"	3 1/4"	.30
6126	13/16"	3 1/4"	.35
6128	7/8"	3 1/4"	.43
6130	15/16"	3 1/4"	.45
6132	1"	3 1/4"	.50
6134	1 1/16"	3 1/4"	.63
6136	1 1/8"	3 1/4"	.65
6140	1 1/4"	3 1/4"	.92

F SPECIAL SPARK PLUG SOCKET

Synthetic rubber insert (see cutaway view) holds spark plugs securely in socket for installation or removal, prevents breakage, speeds work and helps get into hard to reach places; prevents burning fingers on hot manifolds. Hex opening for greater strength.

No.	Opening Size	Length	Wt. Lbs.
6126-HP	13/16"	2 1/2"	.28

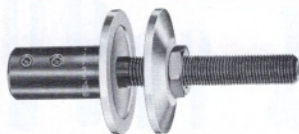
ARBORS**WORK ARBORS**

Maximum capacity between the 2" diameter flanges is 2 1/4". Spindle is 1/2" in diameter with 20 threads per inch for holding power. Shank has two set-screws for sure holding to the shaft. Available in two sizes.

No.	Fits Shaft	Wt. Lbs.
1658	1/2"	.75
1659	5/8"	.75

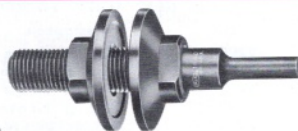
**WHEEL ARBOR**

Designed for 3/4" drills. Handles 1/2" shaft diameter attachments. Maximum distance between the 1 3/8" flanges is 1". Maximum recommended wheel: 4" x 1/2". Shank is 1/4" and can be used in any three-jaw chuck of this or larger size.

No.	Description	Wt. Lbs.
1640	1/4" Drill Arbor	.25

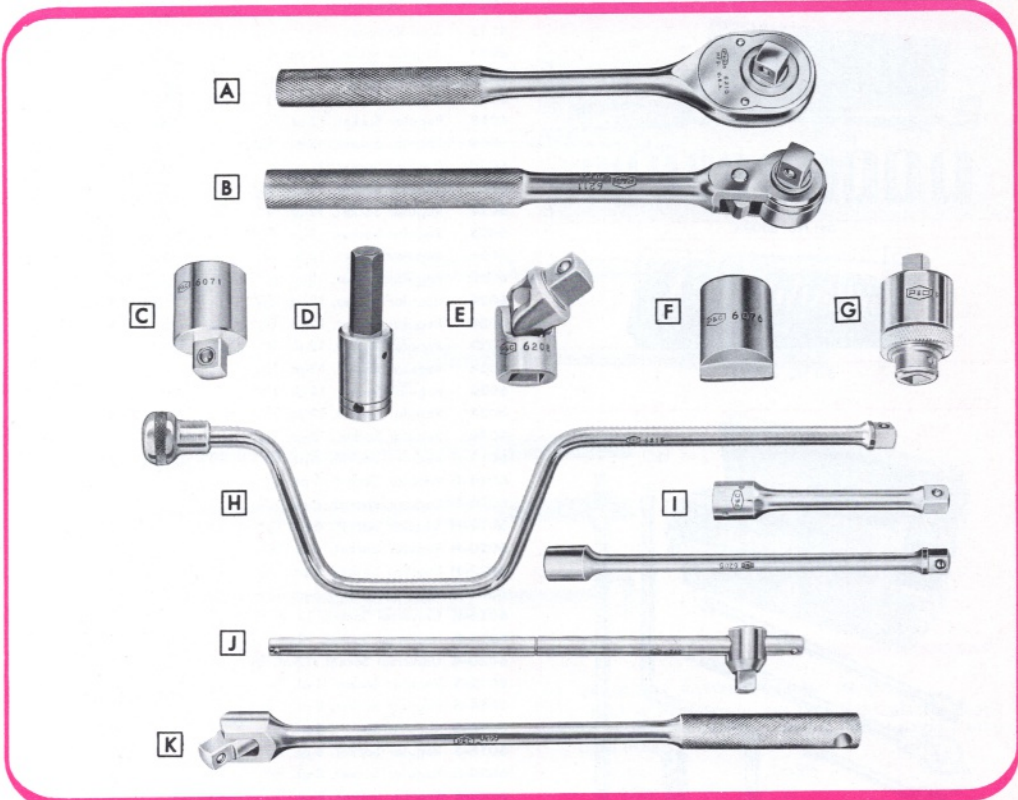

A RATCHET — CLOSED HEAD
Completely enclosed head. Keeps ratcheting and reversing mechanism free of dirt.

No.	Length	Wt. Lbs.
*6210	10"	1.28

B RATCHET — SMALL HEAD
Narrow head design fits in smaller places. Exposed reversing dog works easily.

No.	Length	Wt. Lbs.
*6211	10 1/4"	1.20
*6212	16"	1.80

C ADAPTOR

No.	Length	Wt. Lbs.
6071 (Adapts 3/4" drive handles to 1/2" drive sockets)	1 7/8"	.33
6072 (Adapts 1/2" drive handles to 3/4" drive sockets)	1 3/16"	.25

D HOLLOW HEAD SCREW SOCKETS

No.	Hex. Bit Size	Length	Wt. Lbs.
6290-1/2	1/2"	3 1/8"	.37
6290-3/16	3/16"	3 3/8"	.48
6290-3/8	3/8"	3 3/8"	.52

E UNIVERSAL JOINT

No.	Length	Wt. Lbs.
6208	2 5/16"	.23

F SCREWDRIVER SOCKETS

No.	Bit Size	Length	Wt. Lbs.
6075	3/4" x .115"	1 1/4"	.14
6076	1 5/16" x .154"	1 1/4"	.20

G RATCHETOR
A handy tool in any tool box. Makes any non-ratcheting handle a handy ratcheting tool.

No.	Length	Wt. Lbs.
6247	2 3/16"	.73

H SPEEDER HANDLE

No.	Length	Wt. Lbs.
6215	18"	1.43

I EXTENSIONS

No.	Length	Wt. Lbs.
6202	2 1/2"	.24
6203	5"	.40
6205	10"	.65
6206	18"	1.10

J SLIDING T-HANDLE

No.	Length	Wt. Lbs.
6265	13"	1.30

K HINGE HANDLE

No.	Length	Wt. Lbs.
6230	11"	1.08
6235	15"	1.56
6238	18"	1.70

*See Price List for Replacement Parts

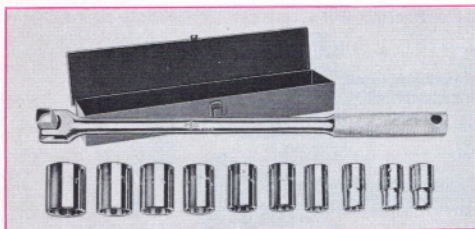

Set No. 6000-C

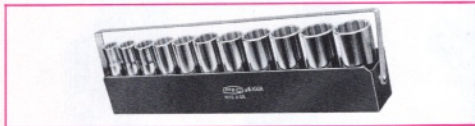

Set No. 6100-A

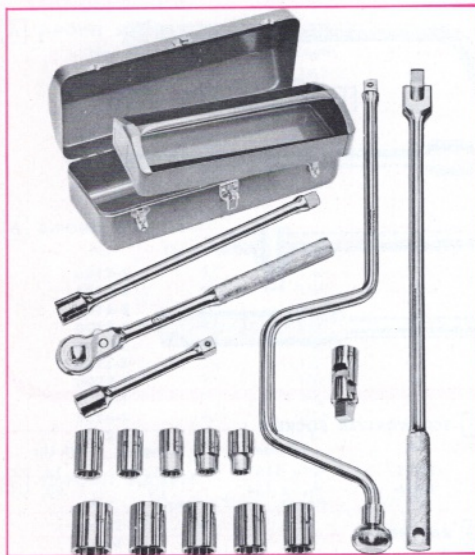

Set No. 6000K

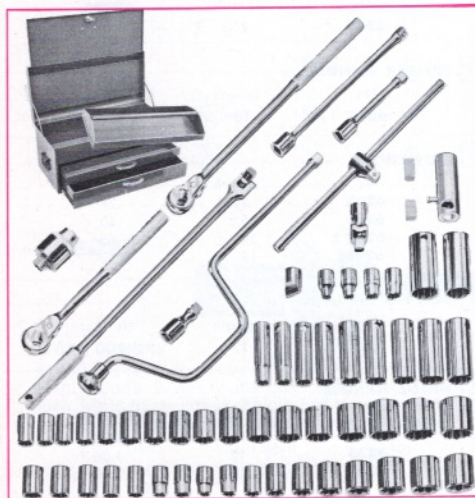

Set No. 6000E

No.	Description	Set No.	Set No.	Set No.	Set No.
		6000C	6000K	6000E	6100A
4515	Stud Remover	X	..
6012	Regular Socket, 12-pt. 3/8"	X	..
6014	Regular Socket, 12-pt. 7/16"	X	X	X	..
6016	Regular Socket, 12-pt. 1/2"	X	X	X	..
6018	Regular Socket, 12-pt. 9/16"	X	X	X	..
6019	Regular Socket, 12-pt. 19/32"	X	..
6020	Regular Socket, 12-pt. 5/8"	X	X	X	..
6022	Regular Socket, 12-pt. 11/16"	X	X	X	..
6024	Regular Socket, 12-pt. 3/4"	X	X	X	..
6025	Regular Socket, 12-pt. 29/32"	X	..
6026	Regular Socket, 12-pt. 13/16"	X	X	X	..
6028	Regular Socket, 12-pt. 7/8"	X	X	X	..
6029	Regular Socket, 12-pt. 29/32"	X	..
6030	Regular Socket, 12-pt. 15/16"	X	X	X	..
6032	Regular Socket, 12-pt. 1"	X	X	X	..
6034	Regular Socket, 12-pt. 1 1/16"	X	..
6036	Regular Socket, 12-pt. 1 1/8"	X	..
6038	Regular Socket, 12-pt. 1 3/8"	X	..
6040	Regular Socket, 12-pt. 1 1/4"	X	..
6012-H	Regular Socket, 6-pt. 3/8"	X	..
6014-H	Regular Socket, 6-pt. 7/16"	X	..
6016-H	Regular Socket, 6-pt. 1/2"	X	..
6018-H	Regular Socket, 6-pt. 9/16"	X	..
6020-H	Regular Socket, 6-pt. 5/8"	X	..
6022-H	Regular Socket, 6-pt. 11/16"	X	..
6024-H	Regular Socket, 6-pt. 3/4"	X	..
6016-K	Universal Socket, 12-pt. 1/2"	X	..
6018-K	Universal Socket, 12-pt. 9/16"	X	..
6020-K	Universal Socket, 12-pt. 5/8"	X	..
6012-S	Regular Socket, 8-pt. 3/8"	X	..
6014-S	Regular Socket, 8-pt. 7/16"	X	..
6016-S	Regular Socket, 8-pt. 1/2"	X	..
6018-S	Regular Socket, 8-pt. 9/16"	X	..
6020-S	Regular Socket, 8-pt. 5/8"	X	..
6022-S	Regular Socket, 8-pt. 11/16"	X	..
6024-S	Regular Socket, 8-pt. 3/4"	X	..
6026-S	Regular Socket, 8-pt. 13/16"	X	..
6028-S	Regular Socket, 8-pt. 7/8"	X	..
6032-S	Regular Socket, 8-pt. 1"	X	..
6076	Drag Link Socket	X	..
6116	Deep Socket, 12-pt. 1/2"	X	X
6118	Deep Socket, 12-pt. 9/16"	X	X
6120	Deep Socket, 12-pt. 5/8"	X	X
6122	Deep Socket, 12-pt. 11/16"	X	X
6124	Deep Socket, 12-pt. 3/4"	X	X
6126	Deep Socket, 12-pt. 13/16"	X	X
6128	Deep Socket, 12-pt. 7/8"	X	X
6130	Deep Socket, 12-pt. 15/16"	X	X
6132	Deep Socket, 12-pt. 1"	X	X
6134	Deep Socket, 12-pt. 1 1/16"	X	X
6136	Deep Socket, 12-pt. 1 1/8"	X	X
6202	Extension, 2 1/2"	X	..
6203	Extension, 5"	..	X	X	..
6205	Extension, 10"	..	X	X	..
6208	Universal Joint, 2 5/16"	..	X	X	..
6211	Reversible Ratchet, 10 1/4"	..	X	X	..
6212	Reversible Ratchet, 16"	X	..
6215	Speeder Handle	..	X	X	..
6235	Hinge Handle, 15"	X
6238	Hinge Handle, 18"	..	X	X	..
6247	Ratchet	X	..
6265	Sliding T-Handle	X	..
5393	Metal Tray	X
5494	Metal Box	X
5497	Metal Box	..	X
9991	Metal Box	X	..

Note: To order set 6000E without box order No. 6000D

3/4" DRIVE SOCKETS, HANDLES AND ATTACHMENTS

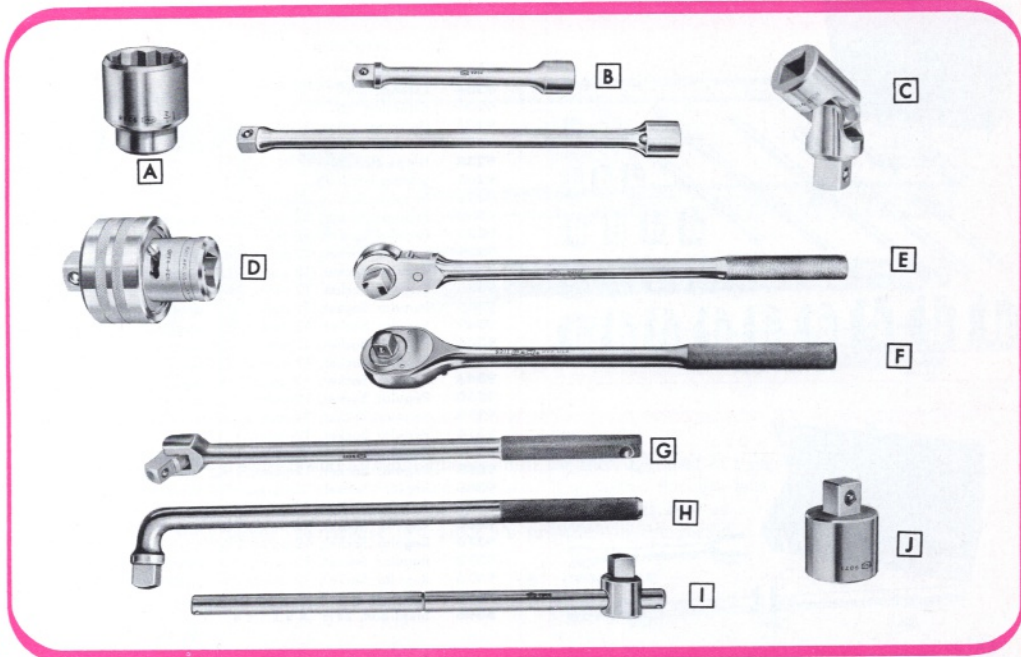

A 12-POINT SOCKETS

No.	Opening Size	Length	Wt. Lbs.
9328	7/8"	2"	.35
9330	15/16"	2"	.40
9332	1"	2"	.43
9334	1 1/16"	2"	.48
9336	1 1/8"	2 1/8"	.53
9338	1 3/16"	2 1/8"	.58
9340	1 1/4"	2 1/8"	.70
9342	1 5/16"	2 1/8"	.70
9344	1 3/8"	2 1/4"	.73
9346	1 7/16"	2 1/4"	.80
9348	1 1/2"	2 1/4"	.85
9350	1 5/8"	2 3/8"	.90
9352	1 3/4"	2 3/8"	1.05
9354	1 7/8"	2 1/2"	1.35
9356	1 3/4"	2 1/2"	1.45
9358	1 13/16"	2 3/8"	1.80
9360	1 7/8"	2 3/8"	1.90
9364	2"	2 3/4"	2.13
9368	2 1/8"	2 3/4"	2.45
9370	2 3/16"	3 1/4"	3.25
9372	2 1/4"	3 3/8"	3.50
9376	2 3/8"	3 3/8"	3.62

B EXTENSIONS

No.	Length	Wt. Lbs.
9203	5"	1.05
9204	8"	1.43
9206	16"	2.30

C UNIVERSAL JOINT

No.	Length	Wt. Lbs.
9208	3 3/4"	1.00

D RATCHETER

Converts any 3/4" square drive non-ratcheting handle into a ratcheting tool. Easily reversed. Fully enclosed.

No.	Length	Wt. Lbs.
9247	3 13/16"	2.35

E REVERSIBLE RATCHET — SMALL HEAD

Small head lets you get into tight places. Easily reversible. Powerful, positive, built to really take hard usage.

No.	Length	Wt. Lbs.
9209	20"	4.00

F REVERSIBLE RATCHET — CLOSED HEAD

Has minimum reverse drag. All closed head keeps out dirt for many years of trouble-free use. Easily reversed with a flip of the finger. Works in very short arc.

No.	Length	Wt. Lbs.
9211	20"	6.20

G HINGE HANDLE

No.	Length	Wt. Lbs.
9238	20"	3.20

H L-HANDLE

No.	Length	Wt. Lbs.
9255	17 1/2"	2.35

I SLIDING T-HANDLE

No.	Length	Wt. Lbs.
9265	18"	2.73

J ADAPTORS

No.	Length	Wt. Lbs.
9071	2 1/2"	1.10
9072	2 1/4"	.58

(Adapts 1" attachment to 3/4" drive sockets)
(Adapts 3/4" attachment to 1" drive sockets)

P&C... Quality Tools for Building America!

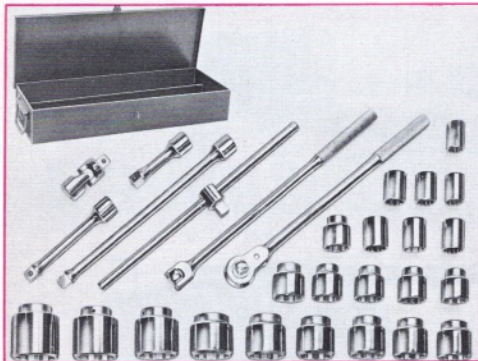

Set No. 9300A

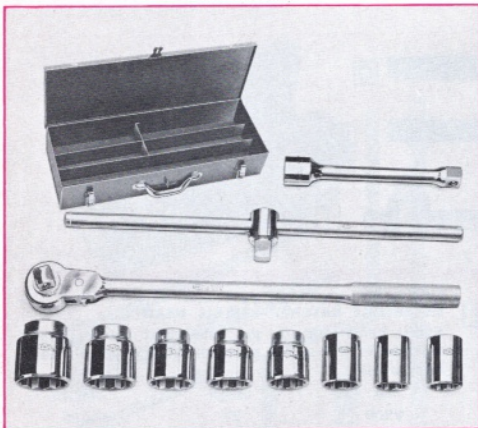

Set No. 9300NR

No.	Description	Set No. 9300A	Set No. 9300NR
9203	Extension, 5"	X	..
9204	Extension, 8"	X	X
9206	Extension, 16"	X	..
9208	Universal Joint, 3/4"	X	..
9209	Reversible Ratchet, 20"	X	X
9238	Hinge Handle	X	..
9265	Sliding T-Handle	X	X
9328	Regular Socket, 12-point, 7/16" opening	X	..
9330	Regular Socket, 12-point, 13/16" opening	X	..
9332	Regular Socket, 12-point, 1" opening	X	..
9334	Regular Socket, 12-point, 1 1/16" opening	X	X
9336	Regular Socket, 12-point, 1 1/8" opening	X	X
9338	Regular Socket, 12-point, 1 3/16" opening	X	..
9340	Regular Socket, 12-point, 1 1/4" opening	X	X
9342	Regular Socket, 12-point, 1 5/16" opening	X	X
9344	Regular Socket, 12-point, 1 3/8" opening	X	..
9346	Regular Socket, 12-point, 1 7/16" opening	X	X
9348	Regular Socket, 12-point, 1 1/2" opening	X	X
9350	Regular Socket, 12-point, 1 5/8" opening	X	..
9352	Regular Socket, 12-point, 1 5/8" opening	X	X
9354	Regular Socket, 12-point, 1 11/16" opening	X	..
9356	Regular Socket, 12-point, 1 3/4" opening	X	X
9358	Regular Socket, 12-point, 1 13/16" opening	X	..
9360	Regular Socket, 12-point, 1 7/8" opening	X	..
9364	Regular Socket, 12-point, 2" opening	X	..
9368	Regular Socket, 12-point, 2 1/8" opening	X	..
9370	Regular Socket, 12-point, 2 3/16" opening	X	..
9372	Regular Socket, 12-point, 2 1/4" opening	X	..
9376	Regular Socket, 12-point, 2 3/8" opening	X	..
5695	Metal Box, 22 1/4" x 8" x 3 3/4"	..	X
5696	Steel Box, 23 1/2" x 9 1/4" x 4"	X	..

Wt. Lbs. 75.00 20.00

Note: To order Set No. 9300A without box order 9300AA.
Weight 66.00 lbs.



SPACELITE[®] ALUMINUM

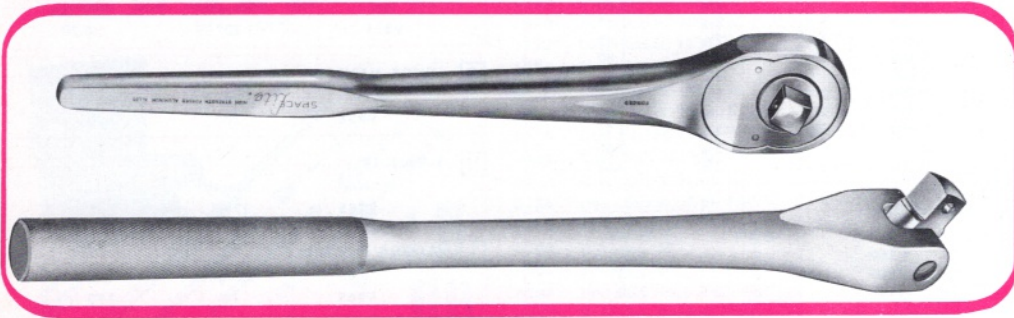

SPACELITE ALUMINUM RATCHET AND HINGE HANDLES

43% lighter than steel! Yet torque performance exceeds Federal specifications for steel ratchets and equals them in strength. Less fatigue. Handle designed for firm, comfortable grip. Strong, dependable alloy steel reversible ratchet mechanism and drive.

No.	Description	Drive	Length	Wt. Lbs.
9210	Ratchet	3/4"	19 3/4"	3.50
9237	Hinge Handle	3/4"	21 1/2"	2.75
9537	Hinge Handle	1"	26"	5.75

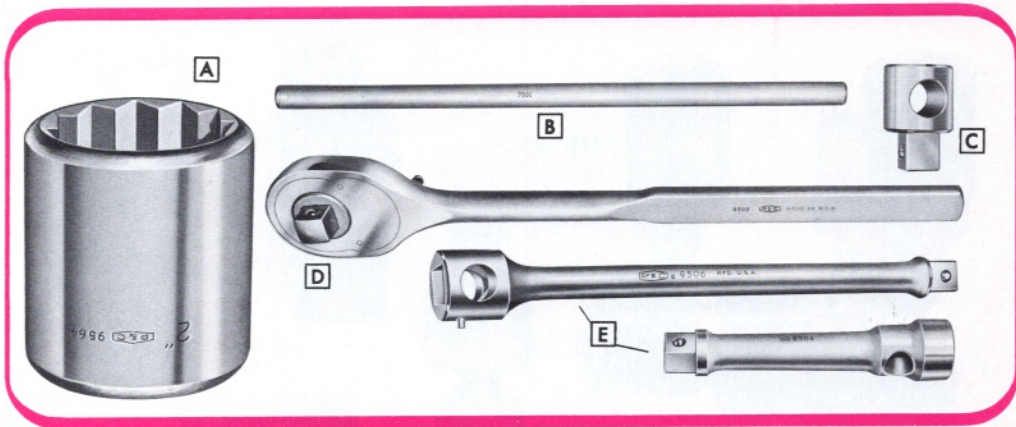

P&C 1" Drive Sockets and attachments are built for the ruggedest of usage. Made of the finest special analysis steel to reduce weight-adding metal. Sockets lock to handles by use of a spring-pellet that snaps into a hole provided. This acts as a retaining pin. A great safety factor. To release just push pin provided in the socket.

A 12-POINT SOCKETS

No.	Opening Size	Length	Wt. Lbs.
9552	1 5/8"	3 1/4"	1.73
9558	1 3/16"	3 3/16"	1.85
9560	1 7/8"	3 3/8"	1.94
9564	2"	3 7/8"	2.20
9570	2 3/16"	3 3/4"	3.10
9572	2 1/4"	3 13/16"	3.40
9576	2 3/8"	3 15/16"	3.90
9580	2 1/2"	4"	4.60
9582	2 7/16"	4"	4.90
9584	2 3/8"	4 1/8"	5.20
9588	2 3/4"	4 3/8"	6.20
9594	2 13/16"	4 3/4"	7.70
9596	3"	4 7/8"	7.90
9600	3 1/8"	4 7/8"	9.60
9612	3 1/2"	5 1/2"	15.00

B CROSS BAR

No.	Length	Wt. Lbs.
9501	24"	5.30

C SLIDING HEAD (For 9501 Bar)

No.	Length	Wt. Lbs.
9565	3"	1.48

D RATCHET

No.	Length	Wt. Lbs.
9509	26"	12.00

E EXTENSIONS

No.	Length	Wt. Lbs.
9504	8"	3.60
9506	18"	6.00



Set No. 9500-B

1" DRIVE SOCKET SETS

No.	Description	Set No. 9500-B	Set No. 9500-OC
9501	Cross Bar, 1" diameter, 24" length	X	X
9504	Extension, 9"	X	X
9506	Extension, 18"	X	..
9509	Reversible Ratchet	X	X
9565	Sliding Head	X	X
9552	Regular Socket, 12-point, 1 5/8" opening	X	..
9558	Regular Socket, 12-point, 1 3/16" opening	X	X
9560	Regular Socket, 12-point, 1 7/8" opening	X	..
9564	Regular Socket, 12-point, 2" opening	X	X
9570	Regular Socket, 12-point, 2 3/16" opening	X	X
9572	Regular Socket, 12-point, 2 1/4" opening	X	..
9576	Regular Socket, 12-point, 2 3/8" opening	X	X
9580	Regular Socket, 12-point, 2 1/2" opening	X	..
9582	Regular Socket, 12-point, 2 7/16" opening	X	..
9584	Regular Socket, 12-point, 2 3/8" opening	X	..
9588	Regular Socket, 12-point, 2 3/4" opening	X	X
9594	Regular Socket, 12-point, 2 13/16" opening	X	..
9596	Regular Socket, 12-point, 3" opening	X	..
9600	Regular Socket, 12-point, 3 1/8" opening	X	..
9612	Regular Socket, 12-point, 3 1/2" opening	X	..
5894	Metal Box, 30" x 8 1/4" x 5"	..	X
5895	Metal Box, 30" x 12 1/2" x 5 1/2"	X	..
	Wt. Lbs.	150	60

All P & C Tools are size marked to speed use on the job.

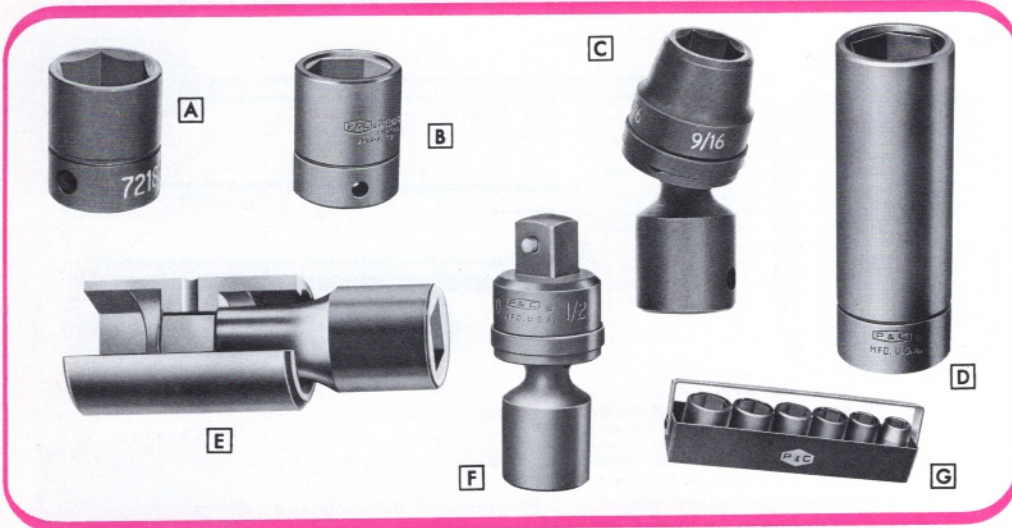

P&C Power and Impact Sockets are rugged, tough, designed to take long-time hard usage. They are made from special analysis tool steel. All points of strain are "beefed up." Finish is black oxide and lacquered. All P&C Power Sockets are exclusive Dyna-Ring for longer life.

3/8" DRIVE POWER SOCKETS

A 6-POINT SOCKETS					
No.	Opening Size	Bolt Depth	Total Length	Wt. Lbs.	
7210-H	5/16"	1 1/32"	1 5/16"	.07	
7212-H	3/8"	1 1/32"	1 5/16"	.05	
7214-H	7/16"	7/16"	1 5/16"	.05	
7216-H	1/2"	7/16"	1 5/16"	.06	
7218-H	9/16"	7/16"	1 5/16"	.07	
7220-H	5/8"	7/16"	1 5/16"	.10	
7222-H	1 1/8"	9/16"	1"	.16	
7224-H	3/4"	9/16"	1"	.21	

1/2" DRIVE POWER SOCKETS

B 6-POINT SOCKETS					
No.	Opening Size	Bolt Depth	Total Length	Wt. Lbs.	
7412-H*	3/8"	9/16"	1 1/2"	.13	
7414-H*	7/16"	9/16"	1 1/2"	.14	
7416-H*	1/2"	9/16"	1 1/2"	.17	
7418-H*	9/16"	3/4"	1 1/2"	.17	
7420-H	5/8"	3/4"	1 1/2"	.22	
7422-H	1 1/16"	13/16"	1 1/2"	.26	
7424-H	3/4"	1 1/8"	1 1/2"	.38	
7426-H	13/16"	1 1/8"	1 1/2"	.31	
7428-H	7/8"	1 1/8"	1 3/4"	.45	
7430-H	1 5/16"	1"	1 3/4"	.48	
7432-H	1"	1 1/4"	2"	.55	
7434-H	1 1/16"	1 1/4"	2"	.66	
7436-H	1 1/8"	1 1/4"	2"	.71	
7438-H	1 3/16"	1 1/4"	2"	.79	
7440-H	1 1/4"	1 1/4"	2"	.79	

*These sizes do not have Dyna-Ring.

C 6-POINT UNIVERSAL SOCKETS					
No.	Opening Size	Bolt Depth	Total Length	Wt. Lbs.	
7474	7/16"	7/16"	2 1/2"	.35	
7475	1/2"	1/2"	2 1/2"	.35	
7476	9/16"	9/16"	2 3/8"	.36	
7477	5/8"	9/16"	2 3/8"	.36	
7478	1 1/16"	9/16"	2 3/8"	.36	
7479	3/4"	3/8"	2 3/8"	.36	

D 6-POINT DEEP LENGTH SOCKETS					
No.	Opening Size	Bolt Depth	Total Length	Wt. Lbs.	
7312-H	3/8"	2 3/16"	3 1/4"	.33	
7314-H	7/16"	2 3/16"	3 1/4"	.33	
7316-H	1/2"	2 3/16"	3 1/4"	.31	
7318-H	9/16"	2 3/16"	3 1/4"	.37	
7320-H	5/8"	2 3/16"	3 1/4"	.36	
7322-H	1 1/16"	2 3/16"	3 1/4"	.41	
7324-H	3/4"	2 3/16"	3 1/4"	.59	
7326-H	13/16"	2 3/16"	3 1/4"	.56	
7328-H	7/8"	2 3/16"	3 1/4"	.62	
7330-H	15/16"	2 3/16"	3 1/4"	.86	
7332-H	1"	2 3/4"	3 1/2"	.90	
7334-H	1 1/16"	2 3/4"	3 1/2"	1.00	
7336-H	1 1/8"	2 3/4"	3 1/2"	1.02	
*57336-H	1 1/8"	5"	5 3/4"	1.76	

*(This special socket has been designed for use on the spindle nut of cotton picking machines.)

E WHEEL LUG SOCKET WRENCH		
No.	Description	Wt. Lbs.
7402W	Wheel Lug Socket Set	.75
(7401 Socket only. 7182-P Extension only)		

F UNIVERSAL JOINT		
No.	Description	Wt. Lbs.
7470	Universal Joint—Ball Type	.38

G 1/2" DRIVE POWER SOCKET SET #7400D		
No.	Description	
7416-H	Regular Socket, 6-point, 1/2" opening	
7418-H	Regular Socket, 6-point, 9/16" opening	
7420-H	Regular Socket, 6-point, 5/8" opening	
7422-H	Regular Socket, 6-point, 11/16" opening	
7424-H	Regular Socket, 6-point, 3/4" opening	
7426-H	Regular Socket, 6-point, 13/16" opening	
9974	Metal Tray with handle lock	
Wt. Lbs. 1.70		



A D



B



C F



E

DYNA-RING® ADDS LIFE TO P&C SOCKETS



Exclusive design feature that adds amazing life to power sockets. Distributes the impact force away from the corners and minimizes splitting. Tested under the severest dynamic strain to assure you the Best Money Can Buy.

1" DRIVE IMPACT SOCKETS

D 4-POINT SOCKET — 1" DRIVE

No.	Opening Size	Bolt Depth	Total Length	Wt. Lbs.
*10013-5S	1 3/16"	7/8"	2 3/16"	1.16

*Designed for Budd Wheels.

E 6-POINT SOCKETS — 1" DRIVE

No.	Opening Size	Bolt Depth	Total Length	Wt. Lbs.
10012	3/4"	1"	2 3/16"	.96
10014	7/8"	1"	2 3/16"	1.04
10015	1 1/16"	1 1/8"	2 3/16"	1.02
10016	1"	1 1/4"	2 3/16"	1.06
10017	1 1/16"	1 1/2"	2 3/16"	1.28
**10018	1 1/8"	1 3/4"	2 3/16"	1.30
10019	1 3/16"	1 3/4"	2 3/16"	1.28
10020	1 1/4"	1 3/8"	2 1/2"	1.28
10021	1 3/8"	1 1/2"	2 3/16"	1.30
10022	1 3/8"	1 3/8"	2 3/16"	1.46
10023	1 7/8"	1 1/2"	2 1/4"	1.46
**10024	1 1/2"	1 1/2"	2 3/4"	1.46
10025	1 3/8"	1 3/8"	2 13/16"	1.56
10026	1 3/8"	1 3/8"	2 7/8"	1.78
10027	1 11/16"	1 3/4"	2 15/16"	1.96
10028	1 3/4"	1 3/4"	3"	2.00
10029	1 13/16"	1 13/16"	3 1/16"	2.50
10030	1 7/8"	1 7/8"	3 1/8"	2.30
10032	2"	1 7/8"	3 1/4"	3.20
10034	2 1/8"	1 7/8"	3 3/8"	3.40
10036	2 1/4"	2"	3 1/2"	4.10
10038	2 3/8"	2"	3 3/8"	4.20
10040	2 1/2"	2 3/8"	4"	4.90

**Suitable for Budd Wheels.

3/4" DRIVE IMPACT SOCKETS

A 4-POINT SOCKET

No.	Opening Size	Bolt Depth	Total Length	Wt. Lbs.
*07513-5S	1 3/16"	1 7/8"	2 7/16"	.82

*Designed for Budd Wheels.

B 6-POINT SOCKETS — 3/4" DRIVE

No.	Opening Size	Bolt Depth	Total Length	Wt. Lbs.
07509	3/16"	3/4"	1 7/8"	.67
07510	3/8"	3/4"	1 7/8"	.67
07511	1/2"	3/4"	1 7/8"	.66
07512	3/4"	1"	1 7/8"	.68
07513	1 3/16"	1"	1 7/8"	.62
07514	7/8"	1"	2"	.70
07515	1 5/16"	1"	2"	.86
07516	1"	1 1/16"	2 1/8"	1.00
07517	1 1/16"	1 1/16"	2 1/16"	1.14
07518	1 1/8"	1 1/8"	2 3/8"	1.28
07519	1 3/16"	1 1/8"	2 3/8"	1.32
07520	1 1/4"	1 1/8"	2 3/8"	1.36
07521	1 3/8"	1 1/8"	2 3/8"	1.42
07522	1 3/8"	1 1/8"	2 1/4"	1.62
07523	1 7/16"	1 5/8"	2 5/8"	1.56
*07524	1 1/2"	1 5/8"	2 3/8"	1.62

**Suitable for Budd Wheels.

C 6-POINT DEEP SOCKET — 3/4" DRIVE

No.	Opening Size	Bolt Depth	Total Length	Wt. Lbs.
*07524-L	1 1/2"	2 3/8"	3 1/2"	2.60

*Designed for Budd Wheels.

F 6-POINT DEEP SOCKET — 1" DRIVE

No.	Opening Size	Bolt Depth	Total Length	Wt. Lbs.
*10024-L	1 1/2"	2 1/4"	3 1/2"	2.40

*Designed for Budd Wheels.

"O" RINGS AND PINS FOR IMPACT SOCKETS

No.	Drive Size	Description	For Sockets Numbered
07500-P	3/4"	Pin	07509 thru 07524
07500-R	3/4"	"O" Ring	07513SS & 07524L
10000-P1	1"	Pin	10012 thru 10024
10000-R1	1"	"O" Ring	10013SS & 10024L
10000-P2	1"	Pin	10025 thru 10040
10000-R2	1"	"O" Ring	

AIR IMPACT WRENCH

Extra Heavy Duty

This P&C Air Impact Wrench will save you time and money and it has built-in ruggedness, that will keep it on the job for years. Has a torque range (fully adjustable at a touch of the finger) of 75-200 ft/lb. Features rugged impact mechanism, balanced 6-vane motor, continuous self-lubrication and built-in oil reservoir. Is encased in strong steel hammer case. Match this gun with P&C Dyna-ring sockets and you have an unbeatable combination for getting the toughest jobs done... fast! Standard and extended anvil models available.

No. load speed 6600 RPM
Average Impacts 1350/Min.
Size Air Inlet 1/4" Pipe Tap
Recommended Hose Size 3/16"

No.	Type Anvil	Overall Length	Wt. Lbs.
AH-16	Standard	6 3/4"	5.56
AH-16-2	Extended	8 3/4"	5.56



Special Impact Wrench Grease
Formulated for this wrench.
No. AH-16-11
1 lb. can



Leather Boot
High quality leather to protect your gun.
No. AH-16-12



Steel Carrying Case
Stores gun and accessories. Heavy gauge with snap-lock lid.
No. AH-16-13



1/2" Drive
Reversible

ELECTRIC IMPACT WRENCH



Made for the professional user by the world's largest maker of hand-held tools for the auto mechanic. This wrench is doubly insulated and may be used with absolute safety even under the dampest conditions. Housing of sturdy aluminum alloy and handle of insulating Lexan. Delivers 2000 impacts per minute with 95-130 pounds of torque. No load speed is 1900 RPM. Will handle up to 3/8" bolt size. This wrench delivers 37% more torque than any comparable priced wrench. Available in both two-cord and three-cord models. Draws 4 amps at 115 volts AC.

No.	Type Cord*	Overall Length	Wt. Lbs. (Less cord)
EN16	2-wire	11 1/16"	6 3/4
EN16-1	3-wire	11 1/16"	6 3/4



POWERFUL
SHOCK SAFE
EASY TO HANDLE
37% MORE TORQUE

1/2" Drive
Reversible



U.S. Patent No. 2,905,037

THE SENSATIONAL P&C CLIK-STOP ADJUSTABLE

- No other adjustable wrench like it.
- Automatically locks in any position setting.
- No levers to move or buttons to push.
- Positively will not creep or crawl.
- Works easily, smoothly to any opening.

The P&C Clik-Stop is the first important improvement to adjustable wrenches since this tool was invented. It overcomes easily and positively the one weakness of the adjustable wrench . . . its tendency to change adjustment while being used. Now with the P&C Clik-Stop you avoid those damaged bolt heads and nuts. No longer do you have to fear skinned knuckles and the hazards from slipping tools. The answer is the fast, positive, locking action of the Clik-Stop. You set it and it stays. Every position is a locked position.

In addition to the Clik-Stop feature, P&C measures up in every other way to make it the finest tool money can buy. This wrench is thinner to fit into tight places. Yet nothing in the way of strength and tightening power has been sacrificed. All important points of stress are "beefed up" with added metal. Only the finest special alloy steel is used. The handle is of I-beam construction for maximum strength. Head is offset $22\frac{1}{2}^\circ$ for turning nuts in tight places. Available in both beautiful chrome and black industrial finish.

CLIK-STOP ADJUSTABLE WRENCH—FULL CHROME FINISH

No.	Length	Max. Opening	Wt. Lbs.
1704-L	4"	$\frac{1}{2}$ "	.10
1706-L	6"	$\frac{3}{4}$ "	.23
1708-L	8"	1"	.54
1710-L	10"	$1\frac{1}{8}$ "	.85
1712-L	12"	$1\frac{3}{8}$ "	1.56
1715-L	15"	$1\frac{11}{16}$ "	3.25
1716-L	16"	$1\frac{7}{8}$ "	3.68
1718-L	18"	$2\frac{1}{8}$ "	4.75
1720-L	20"	$2\frac{1}{2}$ "	6.28

CLIK-STOP ADJUSTABLE WRENCH—INDUSTRIAL FINISH

No.	Length	Max. Opening	Wt. Lbs.
1704-SL	4"	$\frac{1}{2}$ "	.10
1706-SL	6"	$\frac{3}{4}$ "	.23
1708-SL	8"	1"	.54
1710-SL	10"	$1\frac{1}{8}$ "	.85
1712-SL	12"	$1\frac{3}{8}$ "	1.56
1715-SL	15"	$1\frac{11}{16}$ "	3.25
1716-SL	16"	$1\frac{7}{8}$ "	3.68
1718-SL	18"	$2\frac{1}{8}$ "	4.75
1720-SL	20"	$2\frac{1}{2}$ "	6.28

TRY THIS LOCK TEST



Tighten the Clik-Stop on your finger. Try to turn the Golden Knurl. You can't. The weight of the handle alone keeps it locked. Yet it always adjusts easily.

THIS IS HOW THE CLIK-STOP WORKS!

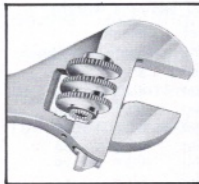

A series of serrations are cast in the Golden Knurl of the Clik-Stop. These serrations lock into teeth forged into the side of the knurl opening. These "locking" elements are kept engaged by a light spring loading of the knurl. There is always full freedom to adjust the wrench and every setting is a locked setting.

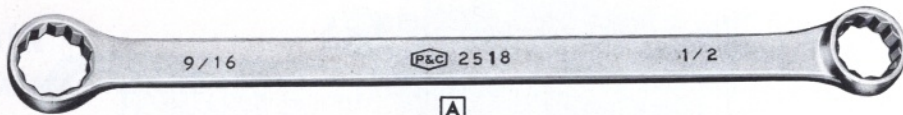

A

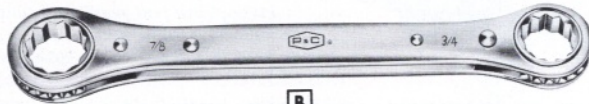

B

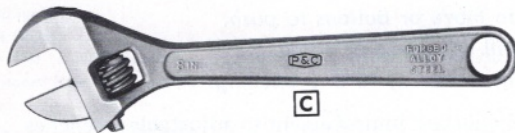

C



D

Hot forging from special alloy steel followed by scientific tempering and precision machining... this is the combination that makes P&C Wrenches unbeatable. Each is shaped for fitting into tight places with thin heads that sacrifice no strength or toughness. Handles are flat and thin with eased edges to make them easy on the hands.

A BOX WRENCHES — 12-POINT

Box openings chamfered to guide wrench onto nut, bolt heads. Once on, it cannot slip or spread, needs only 15° swing to turn a nut. Heads offset 15° from shank to provide knuckle clearance.

No.	Opening Size	Length	Wt. Lbs.
2512	3/16" x 3/8"	5"	.06
2514	3/8" x 7/16"	6 1/2"	.10
2516	7/16" x 1/2"	7 1/2"	.15
2518	1/2" x 5/8"	8"	.20
2520	5/8" x 3/4"	8 1/2"	.25
2522	3/4" x 7/8"	9 1/2"	.35
2524	3/4" x 3/4"	10 3/8"	.40
2525	11/16" x 3/4"	11"	.50
2528	3/4" x 7/8"	12"	.63
2529	13/16" x 7/8"	13 3/8"	.68
2532	15/16" x 1"	15 1/2"	.90
2536	1 1/16" x 1 1/8"	17 1/4"	1.30
2540	1 1/16" x 1 1/4"	18 1/4"	1.38
2542	1 1/4" x 1 3/8"	19 1/4"	1.54
2544	1 1/4" x 1 3/8"	20 1/4"	1.82
2548	1 3/8" x 1 1/2"	21 1/4"	2.00

B RATCHETING BOX WRENCHES — 6 AND 12-POINT

Turning over wrench reverses direction. Laminated construction adds strength and reduces weight.

No.	Opening Size	Type of Opening	Overall Length	Wt. Lbs.
1190	7/16" x 1/2"	6-point	5"	.30
1191	1/4" x 5/16"	6-point	4 1/4"	.12
1192	3/8" x 7/16"	6-point	5 1/2"	.20
1193	1/2" x 3/8"	6-point	6 3/4"	.40
1194	3/8" x 1/2"	12-point	8"	.66
1195	3/4" x 7/8"	12-point	9 1/4"	.79
1196	5/8" x 3/4"	12-point	8 1/8"	.64

C ADJUSTABLE WRENCHES — STANDARD

This wrench is designed for maximum strength with minimum weight. This combination is achieved by engineering skill in design and master craftsmanship in manufacture.

FULL CHROME PLATED

No.	Length	Max. Opening	Wt. Lbs.
1704	4"	1/2"	.10
1706	6"	3/4"	.23
1708	8"	1"	.54
1710	10"	1 1/8"	.85
1712	12"	1 3/8"	1.56
1715	15"	1 1/2"	3.25
1716	16"	1 7/8"	3.68
1718	18"	2 1/8"	4.75
1720	20"	2 1/2"	6.28

INDUSTRIAL FINISH

No.	Length	Max. Opening	Wt. Lbs.
1704-S	4"	1/2"	.10
1706-S	6"	3/4"	.23
1708-S	8"	1"	.54
1710-S	10"	1 1/8"	.85
1712-S	12"	1 3/8"	1.56
1715-S	15"	1 1/2"	3.25
1716-S	16"	1 7/8"	3.68
1718-S	18"	2 1/8"	4.75
1720-S	20"	2 1/2"	6.28

D OBSTRUCTION BOX WRENCHES

Works around corners. Handy for removing, replacing many starter motors.

No.	Opening Size	Length	Wt. Lbs.
1725	3/8" x 1/2"	5 3/8"	.12
1730	3/8" x 5/8"	7 3/4"	.20
1731	5/8" x 3/4"	7 3/4"	.33

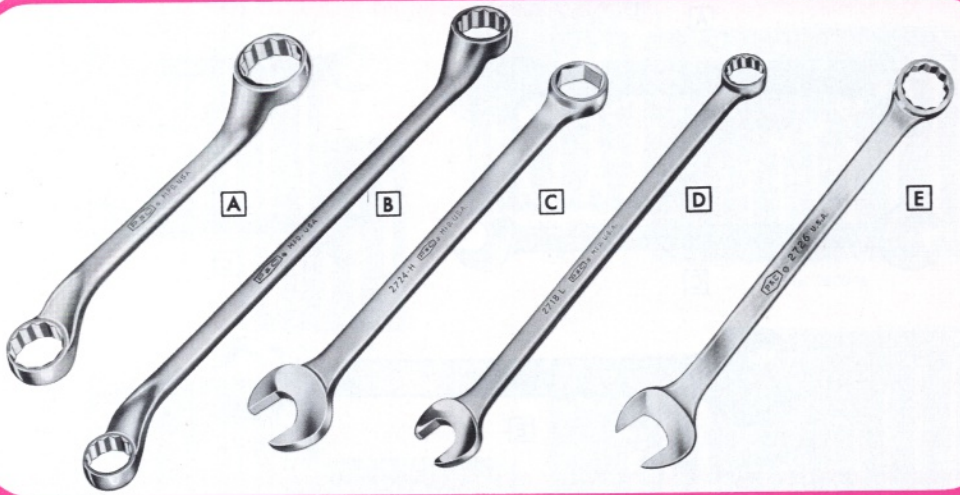

A SHORT OFFSET BOX WRENCH — 12 PT.
Has offset ends to clear nearby obstructions. Short length permits use in tight places.

No.	Opening	Length	Wt. Lbs.
2260	3/8" x 7/16"	5"	.08
2261	1/2" x 3/8"	5 1/2"	.12
2262	5/8" x 11/16"	6"	.19
2263	3/4" x 13/16"	6 1/2"	.25

B LONG OFFSET BOX WRENCH — 12 PT.
Great for reaching into tough spots where ordinary wrench can't be used. Ends offset to clear obstructions.

No.	Opening	Length	Wt. Lbs.
2280	3/8" x 7/16"	7 3/4"	.16
2281	1/2" x 3/8"	9"	.25
2282	5/8" x 11/16"	10 1/4"	.38
2283	25/32" x 13/16"	11 1/2"	.46
2284	3/4" x 3/8"	12 3/4"	.66
2285	5/8" x 1"	14"	.93

C COMBINATION WRENCH — 6 PT.
The right tool to tighten hex nuts. Both ends have same opening size for fast run down and final tightening without changing wrenches. Closed head offset.

No.	Opening	Length	Wt. Lbs.
2712H	3/8"	4 1/2"	.06
2714H	7/16"	5 1/4"	.10
2716H	1/2"	6"	.14
2718H	9/16"	6 3/4"	.20
2720H	5/8"	7 1/2"	.27
2722H	11/16"	8 1/4"	.34
2724H	3/4"	9 1/4"	.45

D COMBINATION WRENCH — LONG — 12 PT.
These wrenches give you extra leverage for tough tightening situations, also reach those hard-to-get-at spots. Same opening on both ends.

No.	Opening	Length	Wt. Lbs.
2708L	1/4"	4 7/8"	.04
2710L	3/8"	5 3/4"	.05
2712L	1/2"	6 5/8"	.08
2714L	7/16"	7 1/2"	.13
2716L	1/2"	8 1/4"	.17
2718L	9/16"	9 1/8"	.25
2720L	5/8"	10"	.33
2722L	11/16"	10 7/8"	.38
2724L	3/4"	11 3/4"	.51

E COMBINATION BOX AND OPEN-END WRENCHES
Box end offset 15° for knuckle clearance, 12-point design turns hex nut with only 15° swing. Open end at 15° angle to shank needs only 30° swing.

No.	12-point Opening	Length	Wt. Lbs.
2708	1/4" (6-pt.)	3"	.02
2710	3/16"	3 3/16"	.05
2712	3/8"	4 1/2"	.07
2714	7/16"	5 5/16"	.10
2716	1/2"	6 1/4"	.14
2718	9/16"	7"	.20
2720	5/8"	7 3/4"	.26
2722	11/16"	8 1/2"	.32
2724	3/4"	9 1/4"	.41
2726	13/16"	10 3/8"	.50
2728	7/8"	11 1/4"	.59
2730	15/16"	12 1/4"	.62
2732	1"	13 3/8"	.86
2734	1 1/16"	14 1/2"	1.03
2736	1 3/16"	15 3/4"	1.23
2740	1 1/4"	17"	1.70
2742	1 3/8"	18 1/4"	1.95
2744	1 3/8"	19 1/2"	2.20
2746	1 7/8"	20 3/4"	2.50
2748	1 1/2"	21 7/8"	2.90
2752	1 5/8"	23"	3.50
2754	1 11/16"	23"	3.40
2756	1 3/4"	26"	5.80
2758	1 13/16"	26"	5.70
2760	1 7/8"	26"	5.60
2764	2"	26"	5.50

P&C Wrenches are all made from special analysis steel that has been alloyed to assure toughness, wear resistance and true tempering. Every wrench is rigidly inspected and fully guaranteed.

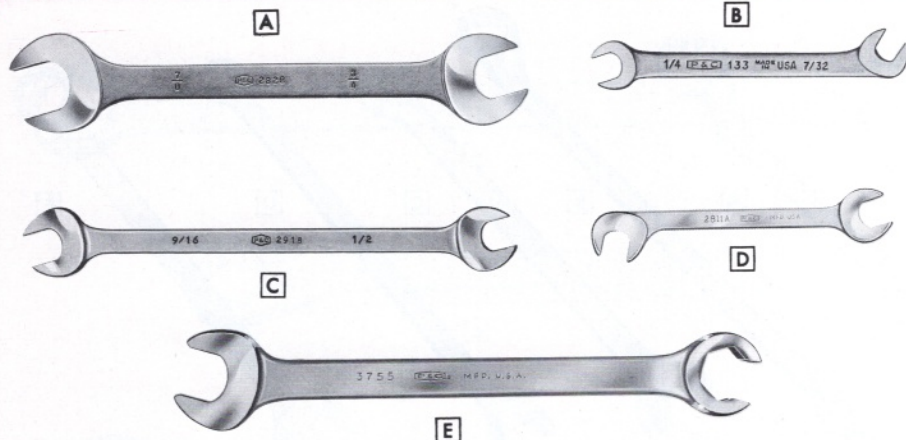

Every P&C Wrench goes through a scientifically controlled and space-age-engineered 17-step process from alloy-steel selection to final inspection and packaging. Over 40 years of tool manufacturing skill is behind every step to assure you the best wrenches money can buy.

A OPEN-END WRENCHES

Jaw openings precisely milled for positive fit without slipping. The 15° jaw angle, by "flopping" wrench, allows continuous turning of hex nut in 30° swing.

No.	Opening	Length	Wt. Lbs.
2808	3/16" x 1/4"	4 1/8"	.02
2810	1/4" x 5/16"	3 1/2"	.05
2812	5/16" x 3/8"	4"	.06
2814	3/8" x 7/16"	4 1/2"	.08
2816	7/16" x 1/2"	5"	.11
2818	1/2" x 5/8"	5 1/2"	.15
2819	1/2" x 9/32"	6"	.15
2820	5/8" x 3/8"	6 1/2"	.21
2821	9/32" x 11/16"	7"	.26
2822	3/4" x 1 1/16"	7 1/2"	.28
2824	3/4" x 3/4"	8 1/4"	.30
2825	1 1/16" x 3/4"	9"	.33
2828	3/4" x 7/8"	10"	.46
2829	13/16" x 7/8"	10 1/2"	.59
2831	7/8" x 1 1/16"	11 1/8"	.70
2832	1 5/16" x 1"	12"	.85
2836	1 1/16" x 1 1/8"	13 3/8"	1.30
2840	1 1/8" x 1 1/4"	14 7/8"	1.50
2842	1 1/4" x 1 3/8"	16 1/4"	2.10
2846	1 3/8" x 1 7/8"	17 3/4"	2.40
2852	1 1/2" x 1 3/4"	19 1/2"	3.80

B MIDJET WRENCHES

One jaw at 15°, other at 60° on each wrench. Opening sizes duplicated at other angle on companion wrench.

No.	15° End	60° End	Length	Wt. Lbs.
130	13/32"	15/32"	3"	.02
131	15/32"	13/32"	3"	.02
132	7/32"	1/4"	3"	.02
133	3/4"	7/32"	3"	.02
134	9/32"	5/16"	3 1/2"	.03
135	5/16"	3/32"	3 1/2"	.03
136	11/32"	3/8"	3 3/4"	.05
137	3/8"	11/32"	3 3/4"	.05

C THIN HEAD OPEN-END WRENCHES

Especially designed for tappet work. Special alloy steel gives extra strength to very thin, tapered jaws. Long handles increase leverage.

No.	Opening	Length	Wt. Lbs.
2916	7/16" x 1/2"	9"	.18
2918	1/2" x 9/16"	9"	.18
2920	5/8" x 3/8"	10"	.24
2925	11/16" x 3/4"	10"	.27
2929	13/16" x 7/8"	10"	.35

D MIDJET OPEN-END WRENCHES — 80°

Designed for work on generators, distributors and electronic equipment. End size is matched and heads are at 15° and 80° angle to shank.

No.	Opening	Length	Wt. Lbs.
2807A	7/32"	3 1/4"	.02
2807AB	15/64"	3 1/4"	.02
2808A	1/4"	3 1/4"	.02
2809A	9/32"	3 5/8"	.03
2810A	5/16"	3 5/8"	.03
2811A	11/32"	4"	.04
2812A	3/8"	4"	.04
2814A	7/16"	4 3/4"	.07
2816A	1/2"	4 3/4"	.07
2818A	9/16"	5 3/4"	.14
2820A	5/8"	5 3/4"	.14

E FLARE NUT WRENCHES

Semi-box head slips over tubing for seating onto flare nuts. For use on fluid or gas lines in hydraulic units, air brake systems, compressors, etc.

No.	6-Point Opening	Length	Wt. Lbs.
3751	3/8"	5 5/8"	.26
3752	7/16"	6"	.30
3753	1/2"	6 3/8"	.34
3754	9/16"	6 7/8"	.40
3755	5/8"	7 5/8"	.47
3756	11/16"	8 3/4"	.54
3757	3/4"	9 1/4"	.65

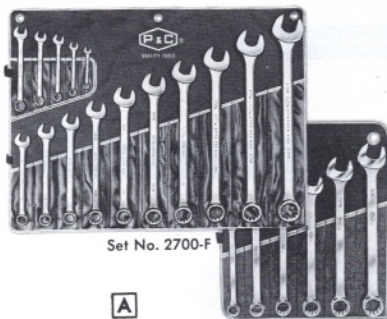

Set No. 2700-F

A

Set No. 2700-B



Set No. 2800-B

B

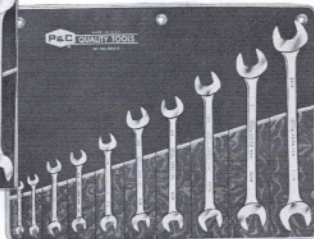

Set No. 2800-H

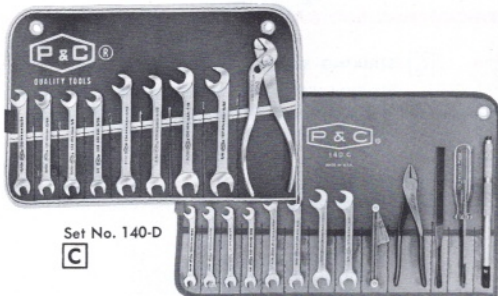

Set No. 140-D

C

Set No. 140-C

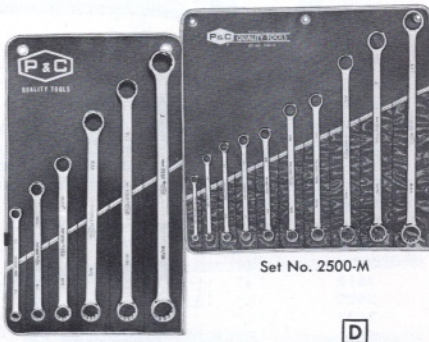

Set No. 2500-M

Set No. 2500-B

D

A COMBINATION WRENCH SETS

No.	Description	Set No. 2700B	Set No. 2700F
2710	5/16" opening	..	X
2712	3/8" opening	..	X
2714	7/16" opening	X	X
2716	1/2" opening	X	X
2718	9/16" opening	X	X
2720	5/8" opening	X	X
2722	11/16" opening	X	X
2724	3/4" opening	X	X
2726	13/16" opening	..	X
2728	7/8" opening	..	X
2730	15/16" opening	..	X
2732	1" opening	..	X
2734	1 1/16" opening	..	X
2736	1 1/8" opening	..	X
2740	1 1/4" opening	..	X
2413	Plastic Kit	..	X
2427	Plastic Kit	X	..
Wt. Lbs.		1.70	10.00

C IGNITION WRENCH SETS

No.	Description	Set No. 140-C	Set No. 140-D
	15° End 60° End		
130	13/64" 15/64"	X	X
131	15/64" 13/64"	X	X
132	7/32" 1/4"	X	X
133	1/4" 7/32"	X	X
134	9/32" 5/16"	X	X
135	5/16" 9/32"	X	X
136	11/32" 3/8"	X	X
137	3/8" 11/32"	X	X
442	Screwdriver	X	..
1235	Pliers	..	X
1281	Pliers	X	..
2302	Point File — 5"	X	..
9503	Screw Starter	X	..
000-D	Ignition Gauge Set	X	..
2416	Vinyl Kit	..	X
2420	Vinyl Kit	X	..
Wt. Lbs.		.50	.60

B OPEN-END WRENCH SETS

No.	Description	Set No. 2800B	Set No. 2800H
2810	1/4" x 5/16" opening	..	X
2812	3/8" x 3/8" opening	X	X
2816	7/16" x 1/2" opening	X	X
2818	1/2" x 7/16" opening	..	X
2820	9/16" x 5/8" opening	X	X
2824	5/8" x 3/4" opening	..	X
2825	11/16" x 3/4" opening	X	X
2829	13/16" x 7/8" opening	X	X
2832	15/16" x 1" opening	X	X
2836	1 1/16" x 1 1/8" opening	..	X
2410	Plastic Kit	..	X
2428	Plastic Kit	X	..
Wt. Lbs.		2.50	4.60

D BOX WRENCH SETS

No.	Description	Set No. 2500B	Set No. 2500M
2512	5/16" x 3/8" opening	..	X
2514	3/8" x 7/16" opening	X	X
2516	7/16" x 1/2" opening	..	X
2518	1/2" x 9/16" opening	X	X
2520	9/16" x 5/8" opening	..	X
2522	5/8" x 11/16" opening	X	..
2524	3/4" x 3/4" opening	..	X
2525	11/16" x 3/4" opening	..	X
2528	3/4" x 7/8" opening	X	..
2529	13/16" x 7/8" opening	X	X
2532	15/16" x 1" opening	X	X
2536	1 1/16" x 1 1/8" opening	..	X
2418	Vinyl Kit	..	X
2425	Vinyl Kit	X	..
Wt. Lbs.		3.30	5.20

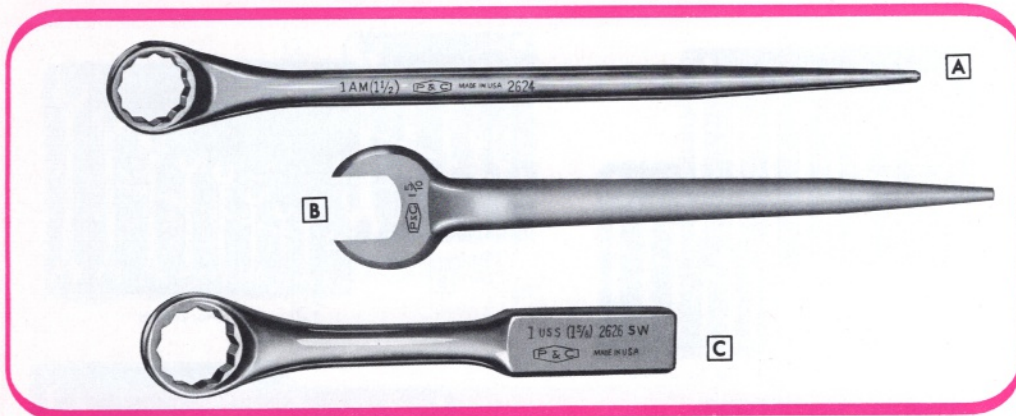
**A SPUD-END WRENCHES — 12-POINT BOX**

Makes quick work of loosening frozen or rusted bolts or nuts. The spud end is handy for aligning holes in flanges. Note the clearance provided by the offset head which overcomes the usual obstruction problems.

No.	Size	Total Length	Wt. Lbs.
2615	1 $\frac{3}{16}$ "	14 $\frac{1}{2}$ "	1.13
2617	1 $\frac{1}{8}$ "	15 $\frac{3}{8}$ "	1.30
2618	1 $\frac{1}{8}$ "	16 $\frac{1}{4}$ "	1.94
2620	1 $\frac{1}{4}$ "	17"	2.20
2623	1 $\frac{7}{16}$ "	19"	3.00
2624	1 $\frac{1}{2}$ "	20 $\frac{1}{8}$ "	3.30
2626	1 $\frac{3}{8}$ "	21 $\frac{1}{4}$ "	3.60
2627	1 $\frac{1}{2}$ "	22 $\frac{1}{4}$ "	3.70
2629	1 $\frac{3}{8}$ "	23 $\frac{1}{4}$ "	5.50
2630	1 $\frac{7}{8}$ "	24 $\frac{1}{4}$ "	5.60
2632	2"	25 $\frac{1}{4}$ "	6.00
2635	2 $\frac{3}{16}$ "	26"	6.40
2638	2 $\frac{3}{8}$ "	26 $\frac{1}{2}$ "	7.00
2641	2 $\frac{7}{16}$ "	28"	8.70
2644	2 $\frac{3}{4}$ "	29"	8.20
2647	2 $\frac{13}{16}$ "	29 $\frac{3}{4}$ "	12.00

C STRIKING WRENCHES — 12-POINT BOX

Striking wrenches have a square striking surface for use with a sledge or hammer. They are offset to allow maximum clearance.

No.	Size	Total Length	Wt. Lbs.
2617-SW	1 $\frac{1}{8}$ "	8 $\frac{1}{2}$ "	1.70
2618-SW	1 $\frac{1}{8}$ "	8 $\frac{1}{2}$ "	1.60
2620-SW	1 $\frac{1}{4}$ "	10 $\frac{3}{4}$ "	3.20
2621-SW	1 $\frac{3}{8}$ "	10 $\frac{3}{4}$ "	3.00
2623-SW	1 $\frac{7}{8}$ "	12"	4.70
2624-SW	1 $\frac{1}{2}$ "	12"	4.40
2626-SW	1 $\frac{3}{8}$ "	12 $\frac{1}{2}$ "	4.60
2627-SW	1 $\frac{1}{2}$ "	12 $\frac{1}{2}$ "	4.50
2629-SW	1 $\frac{3}{8}$ "	13 $\frac{1}{8}$ "	6.60
2630-SW	1 $\frac{7}{8}$ "	13 $\frac{1}{8}$ "	6.80
2632-SW	2"	13 $\frac{1}{8}$ "	6.60
2635-SW	2 $\frac{3}{16}$ "	13 $\frac{3}{8}$ "	8.20
2638-SW	2 $\frac{3}{8}$ "	13 $\frac{3}{8}$ "	7.80
2641-SW	2 $\frac{7}{16}$ "	13 $\frac{3}{8}$ "	8.70
2644-SW	2 $\frac{3}{4}$ "	13 $\frac{3}{8}$ "	8.20
2647-SW	2 $\frac{13}{16}$ "	16"	13.00
2650-SW	3 $\frac{1}{8}$ "	16"	12.00

B STRUCTURAL WRENCHES — OPEN END

Tapered handle aligns bolt holes. Offset handle to clear adjoining bolts, protect operator's hands. Hot forged from special analysis alloy steel, scientifically heat treated for greatest strength and longest wear. Sand blasted satin finish clear lacquer coated.

No.	Opening Size	Length	Wt. Lbs.
924	3/4"	11"	.80
926	1 $\frac{1}{8}$ "	12 $\frac{1}{8}$ "	.90
928	7/8"	12 $\frac{1}{8}$ "	.90

No.	Opening Size	Length	Wt. Lbs.
932	1"	13"	1.30
934	1 $\frac{1}{8}$ "	14"	1.50
936	1 $\frac{1}{8}$ "	14"	1.50
940	1 $\frac{1}{4}$ "	16"	2.50
942	1 $\frac{3}{8}$ "	16"	2.50
946	1 $\frac{7}{16}$ "	18"	3.80
948	1 $\frac{1}{2}$ "	18"	3.80
952	1 $\frac{3}{8}$ "	20"	5.80

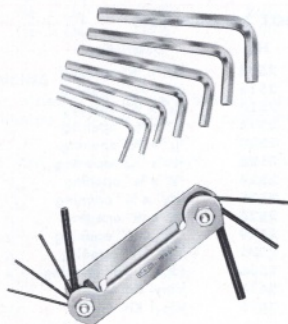
**HOLLOW HEAD WRENCH SET**

This set has seven of the most popular sizes to fit Allen head screws. Hexagon shape in leverage providing "L" form. Sizes 5/64 (fits No. 8 set screws), 3/32 (No. 10), 1/8 (1/4"), 5/32 (5/16"), 3/16 (3/8"), 7/32 (7/16") and 1/4 (1/2").

No.	Item	Wt. Lbs.
4977	Wrench Set with plastic case	.20

HEX KEY SET

Holds seven hex keys for Allen heads, socket head and hollow head screws all in a handy pocket size case. Wrenches fit sizes 4 through 3/16".

No.	Item	Wt. Lbs.
4978	Set in metal case	.16

See page 35 for Socket Drive Allen Head Wrenches



A DRAG LINK AND SHOCK ARM TOOL
Slim, tapered fork is designed to facilitate insertion. Fork opening, 21/32".

No.	Length	Wt. Lbs.
6545	16"	2.30

B PITMAN ARM PRY BAR
Use for pulling bearings, pulleys, gears, for lifting blocks, heavy parts. Fork opening, 1 1/4".

No.	Length	Wt. Lbs.
6546	20"	2.80

C PISTON RING COMPRESSOR
Band-operating ratchet prevents breakage and slippage. Wide band (3 1/2") has 2 1/8" to 5" range. Ell handle included.

No.	Wt. Lbs.
2316	.70

D VALVE GUIDE CLEANER
Turning a nut adjusts the five flexible blades to any valve guide size.

No.	Length	Wt. Lbs.
2335	9 3/4"	.10

E GASKET SCRAPER
Has U.L. approved handle of tough, fire-resistant plastic, and forged blade of special alloy steel.

No.	Blade Width	Length	Wt. Lbs.
2336	1 1/2"	11 1/4"	.41

F FLEXIBLE CARBON SCRAPER
Sliding band regulates the flexibility.

No.	Blade Width	Length	Wt. Lbs.
2337	1"	9"	.30

G CONNECTING ROD SOCKET
Thin nose, hexagon, 1/2" drive socket for Ford V8s.

No.	Opening	Length	Wt. Lbs.
6523	3/16"	1 3/8"	.11

H CARBURETOR JET WRENCHES
Turns jets quickly without damaging soft jet metal.

No.	Fits	Wt. Lbs.
6526	Fits Holley and Chandler-Groves carburetors	.07
6528	Fits most Strombergs	.06

I DISTRIBUTOR POINT SOCKET
For Chevrolets. Two prongs turn the housing terminal screw. Alloy steel. Drive, 1/4".

No.	Length	Wt. Lbs.
6535	1 1/8"	.02

J VALVE LIFTER
Ford V8-85. Long leverage breaks loose the toughest guides. Stock, 3/4". Alloy steel.

No.	Length	Wt. Lbs.
6539	30"	3.50

K IGNITION POINT FILE
Blade is 5/16" wide and 5 1/4" long.

No.	Description	Wt. Lbs.
2302	Ignition Point File	.02

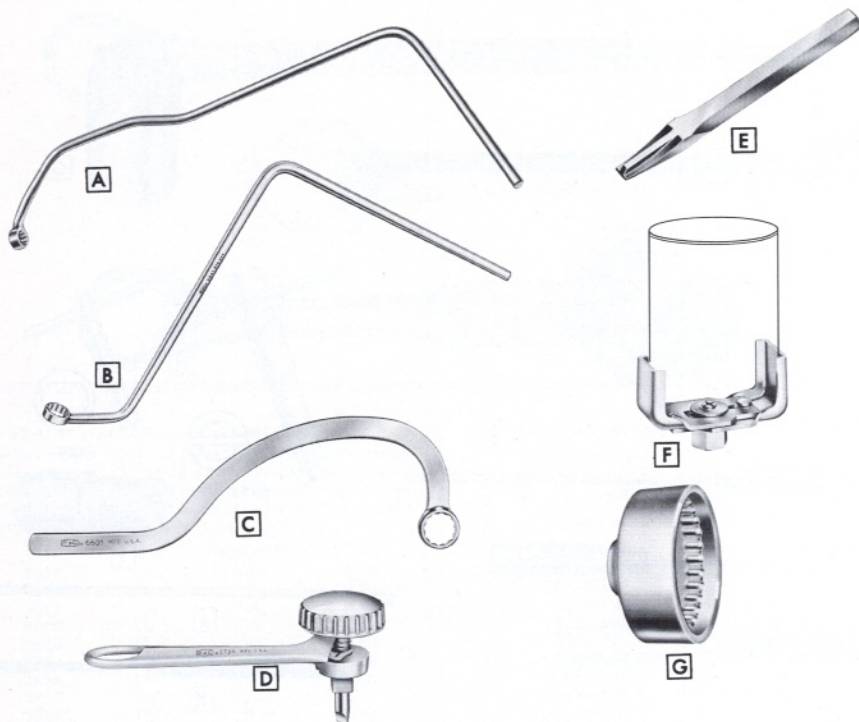
**A UNIVERSAL DISTRIBUTOR WRENCH**

Designed especially for '57 Fords, but desirable wherever $\frac{1}{2}$ " hold-down nuts are used on distributors. Alloy steel, chrome plated.

No.	Length	Wt. Lbs.
6540	17"	.70

B BUICK DISTRIBUTOR WRENCH

For reaching and turning distributor mounting bolt on certain Buicks. Head has 12-point, $\frac{9}{16}$ " box opening and is offset $1\frac{1}{8}$ " to clear obstructions. Alloy steel.

No.	Length	Wt. Lbs.
6541	$10\frac{3}{8}$ " x 8"	.57

C STARTER WRENCH

For Plymouth, Dodge, DeSoto and Chrysler cars. Clears objects when removing or replacing starter. $\frac{5}{8}$ " box opening. Alloy steel.

No.	Length	Wt. Lbs.
6601	$9\frac{3}{4}$ "	.35

D OVERHEAD VALVE ADJUSTERS

For accuracy, speed and ease when adjusting overhead valves. Using a $\frac{1}{2}$ " drive socket, loosen lock nut, turn alloy steel screwdriver with knob for adjustment (setting valve clearance with feeler gauges), and tighten lock nut with handle while holding screwdriver knob. Also used with clutch adjusting machines.

For all 6-cylinder and many V8 overhead valve engines without hydraulic lifters. Has clearance for

D OVERHEAD VALVE ADJUSTERS—Continued

adjusting valves under fire wall on certain 6-cylinder Chevrolets.

No.	Max. Bit Length	Wt. Lbs.
6734	$1\frac{3}{8}$ "	.33
6735	$3\frac{3}{32}$ "	.36

E MUFFLER REMOVAL TOOL

Best way yet to remove worn out mufflers and tail-pipes! Safe, fast and easy to use. Helps prevent damage to usable parts. Made of special high-strength alloy steel.

No.	Length	Wt. Lbs.
2301	5 $\frac{7}{8}$ "	.29

F OIL FILTER REMOVAL TOOL

Takes a vise-like grip to remove oil filters in a breeze! Self locking, self adjusting. Use on most standard domestic units and many foreign types of disposable filters. Designed to protect hands and arms from hot manifolds.

No.	Wt. Lbs.
2304	.90

G FORD FUEL FILTER WRENCH

Eliminates damage and distortion to fuel filter bowls. Special socket gives precise fit and makes removal easy. Made of high-strength die-cast aluminum.

No.	Wt. Lbs.
2303	.30

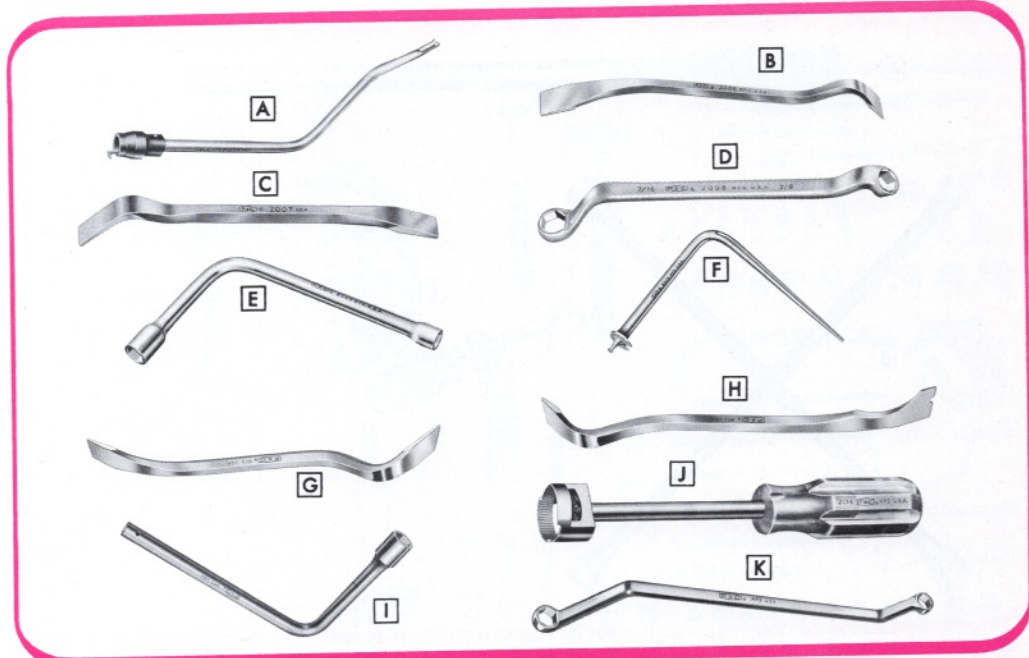
**A BRAKE ADJUSTING TOOL**

To remove and replace Bendix Brake Springs (General Motors' cars and many others) and any type where the spring is attached to a post. Replaceable spring removal socket.

No.	Wt. Lbs.
2005	.40

B BENDIX BRAKE ADJUSTING TOOL

Adjusts star nuts on two-shoe Bendix brakes. Has 1 $\frac{3}{4}$ " spoons.

No.	Length	Wt. Lbs.
2006	9 $\frac{1}{16}$ "	.30

C CHEVROLET BRAKE ADJUSTING TOOL

For Chevrolet brakes and other close places. Has 1-3/16" and 1-7/16" spoons.

No.	Length	Wt. Lbs.
2007	6 $\frac{15}{16}$ "	.18

D CHRYSLER BRAKE WRENCH

Has $\frac{3}{8}$ " hex socket for brake bleeder screws and 7/16" hex socket for adjusting screw in late Chryslers and DeSotos. Clears tires. Alloy steel.

No.	Length	Wt. Lbs.
2008	7 $\frac{5}{16}$ "	.19

E BRAKE BLEEDER WRENCH

For Chevrolets, Fords and Lincolns with ball-joint front end suspension. L-shaped handle has 5/16" hex socket to remove bleeder screw cap and $\frac{3}{8}$ " hex socket for turning screw. Alloy steel.

No.	Length	Wt. Lbs.
2009	6 $\frac{3}{4}$ "	.24

F CHRYSLER BRAKE SPRING TOOL

Forged, milled and swaged from alloy steel, this tool designed to quickly remove and replace brake shoe returns on certain Chryslers, DeSotos, Dodges and Plymouths.

No.	Length	Wt. Lbs.
2010	5 $\frac{1}{2}$ " x 6 $\frac{1}{2}$ "	.25

G CORVAIR BRAKE TOOL

Designed to clear suspension systems in Corvaire, Chevrolet and Buick. Opposite end adjusts many other Bendix brakes.

No.	Length	Wt. Lbs.
2011	9"	.29

H PONTIAC TEMPEST BRAKE TOOL

This tool clears suspension obstructions on front wheels of this car. Special angled blade with notches speeds the jobs.

No.	Length	Wt. Lbs.
2012	9 $\frac{1}{16}$ "	.28

I BRAKE BLEEDER TOOL

Has $\frac{1}{4}$ " hex opening for compact cars; $\frac{3}{8}$ " hex for conventional cars and trucks. Vent hole lets line be bled without removing tool.

No.	Length	Wt. Lbs.
2013	6 $\frac{3}{4}$ "	.24

J BRAKE SHOE TOOL

Removes and replaces the dished retaining washer of spring assembly. Does the job quick and easy.

No.	Length	Wt. Lbs.
2014	7"	.33

K CHRYSLER BRAKE TOOL

Designed for late models. Clears all obstructions. Has $\frac{3}{8}$ " and 7/16" hex openings to handle bleeder and shoe.

No.	Length	Wt. Lbs.
2015	10"	.28

Every P&C Tool is **GUARANTEED** against defects in workmanship or materials. You can buy P&C with confidence.

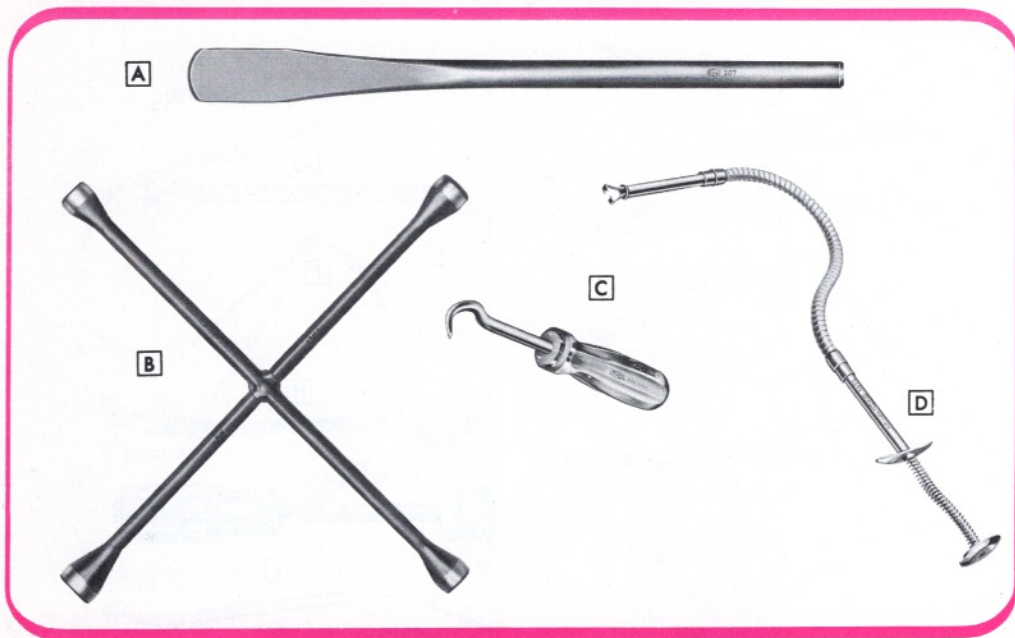
**A BROAD TIRE IRON**

Paddle shaped blade lifts larger area of tire from rim. Thin blade gives best balance with light weight. Hot forged alloy steel with dipped, satin finish.

No.	Description	Wt. Lbs.
207	18"	2.00

B FOUR-WAY LUG WRENCHES

Forged from alloy steel and induction welded for greatest strength and durability. Hex openings. Two sizes to clear wide fenders.

No.	Size	Length	Wt. Lbs.
1175	3/4" x 13/16" x 3/4" x 7/8"	18"	3.00
1176	3/4" x 13/16" x 3/4" x 7/8"	21 1/2"	3.20

C COTTER PIN PULLER

Even the toughest give way with this puller. Just insert point and pry pin out. Exerts big leverage and is built to take it. Hand easy handle.

No.	Length	Wt. Lbs.
2306	7 3/4"	.25

D GRAB-ALL

Will hold or retrieve both metal and non-metal items. Flexible. Two grippers are spring loaded. The handiest tool you'll ever own to get into impossible places.

No.	Length	Wt. Lbs.
2344	17 1/2"	.18
2345	26"	.30

**AUTOMATIC TRANSMISSION SET**

For adjusting all auto and light truck automatic transmissions. Here are all the special tools needed for this important maintenance work. Every item precision engineered to fit the need. Handy reference chart with adjustment specs and easy-to-understand instruction book included in the sturdy metal storage box.

No. 2350-A — Weight 6.50

Consists of the following:

No.	Description	No.	Description
2361	Chart	4710-S	5/16" Socket, 1/4" Drive
9973	Metal Box	4710	3/16" Socket, 1/4" Drive
5324	3/4" Opening, 1/2" Drive Socket	4743	Screwdriver Bit
2357	Band Adjuster	2359	Handle & 1/4" Gauge
2353	1/4" Gauge	2354	Servo Gauge—Front
6061	Torque Wrench, 1/4" Drive	2355	Servo Gauge—Rear
4742	1/4" Allen Hex Socket	2356	3/8" O. E. Wrench
4741	5/32" Allen Hex Socket	2352	3/8" O. E. Wrench

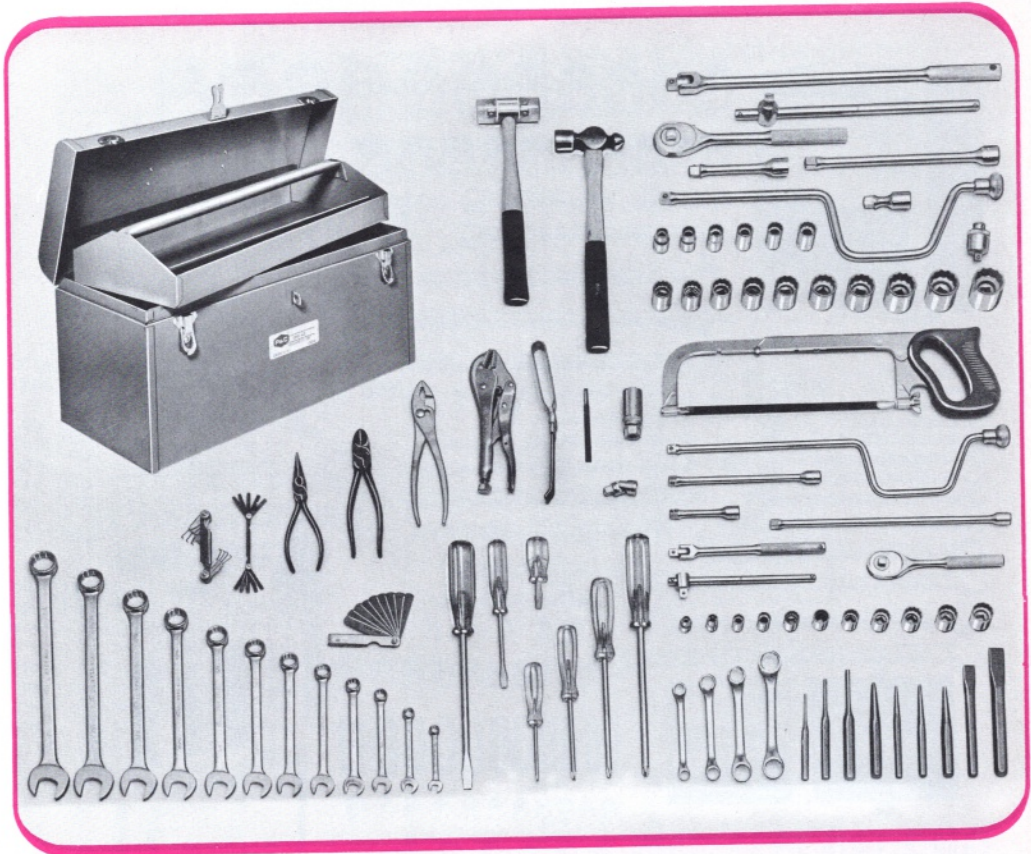

No. 9912 BASIC TOOL SET

Here's a carefully selected set of the 88 most-needed hand tools that will enable any mechanic to handle the service and repair jobs encountered in a normal day. Use it as a starting tool set—add more P&C tools later as needed.

No.	Description	No.	Description	No.	Description
000A	Feeler Gauge Set—9 short blades, .003 - .018	2263	3/4" x 13/16" Short Box Wrench	3210	Ratchet, closed head, 3/8" Drive
000D	Ignition Gauge Set—10 blades, .013 - .040	2302	Distributor Point File	3215	Speed Handle, 3/8" Drive
000K	Spark Plug Gauge Set—complete	2337	Flexible Carbon Scraper	3230	Hinge Handle, 3/8" Drive
12A	1/2" Cut Cold Chisel	2710	5/16" Combination Wrench	3260	Sliding "T", 3/8" Drive
14	3/4" Cut Cold Chisel	2712	3/8" Combination Wrench	6014	7/16", 1/2" Drive Socket
23	1/2" Center Punch	2714	7/16" Combination Wrench	6016	1/2", 1/2" Drive Socket
61	1/8" Point, Pin Punch	2716	1/8" Combination Wrench	6018	9/16", 1/2" Drive Socket
63	3/16" Point, Pin Punch	2718	9/16" Combination Wrench	6019	19/32", 1/2" Drive Socket
64-1	1/4" Point, Pin Punch	2720	3/8" Combination Wrench	6020	5/8", 1/2" Drive Socket
65	1/8" Point Starter Punch	2722	11/16" Combination Wrench	6022	11/16", 1/2" Drive Socket
66	5/32" Point Starter Punch	2724	3/4" Combination Wrench	6024	3/4", 1/2" Drive Socket
67	3/16" Point Starter Punch	2726	13/16" Combination Wrench	6025	29/32", 1/2" Drive Socket
573	No. 1 Phillips Screwdriver	2728	7/8" Combination Wrench	6026	13/16", 1/2" Drive Socket
601	1/4" x 1 1/2" Blade Screwdriver	2730	1 5/8" Combination Wrench	6028	7/8", 1/2" Drive Socket
634	1/4" x 4" Blade Screwdriver	2732	1" Combination Wrench	6030	1 5/8", 1/2" Drive Socket
674	No. 2 Phillips Screwdriver	3010H	5/16", 3/8" Drive Socket	6032	1", 1/2" Drive Socket
776	No. 3 Phillips Screwdriver	3012H	3/8", 3/8" Drive Socket	6034	1 1/16", 1/2" Drive Socket
838	3/8" x 8" Blade Screwdriver	3014H	7/16", 3/8" Drive Socket	6036	1 1/8", 1/2" Drive Socket
878	No. 4 Phillips Screwdriver	3016H	1/2", 3/8" Drive Socket	6038	1 3/16", 1/2" Drive Socket
1207	7" Diagonal Cutting Pliers	3018	9/16", 3/8" Drive Socket	6040	1 1/4", 1/2" Drive Socket
1220	Needle Nose Pliers	3019	19/32", 3/8" Drive Socket	6202	2 1/2" Extension, 1/2" Drive
1278	8" Slip Joint Pliers	3020	5/8", 3/8" Drive Socket	6203	5" Extension, 1/2" Drive
1291R	Lever Wrench Pliers—quick release	3022	11/16", 3/8" Drive Socket	6205	10" Extension, 1/2" Drive
1361	Hacksaw—rigid frame for 10" and 12" blades	3024	3/4", 3/8" Drive Socket	6210	Ratchet, Closed Head, 1/2" Drive
1383	Plastic Tip Hammer	3026	1 1/16", 3/8" Drive Socket	6215	Speed Handle, 1/2" Drive
2260	3/8" x 3/16" Short Box Wrench	3028	7/8", 3/8" Drive Socket	6238	Hinge Handle, 1/2" Drive
2261	1/2" x 3/16" Short Box Wrench	3126HP	1 3/16" Spark Plug Socket	6247	Ratchet, 1/2" Drive
2262	3/8" x 11/16" Short Box Wrench	3202	3 1/2" Extension, 3/8" Drive	6265	Sliding "T", 1/2" Drive
		3203	8" Extension, 3/8" Drive	8612	3/4 lb. Ball Pein Hammer
		3205	12" Extension, 3/8" Drive	D-1120	20" x 8 1/2" x 9 5/8" Metal Box
		3208	Universal Joint, 3/8" Drive		

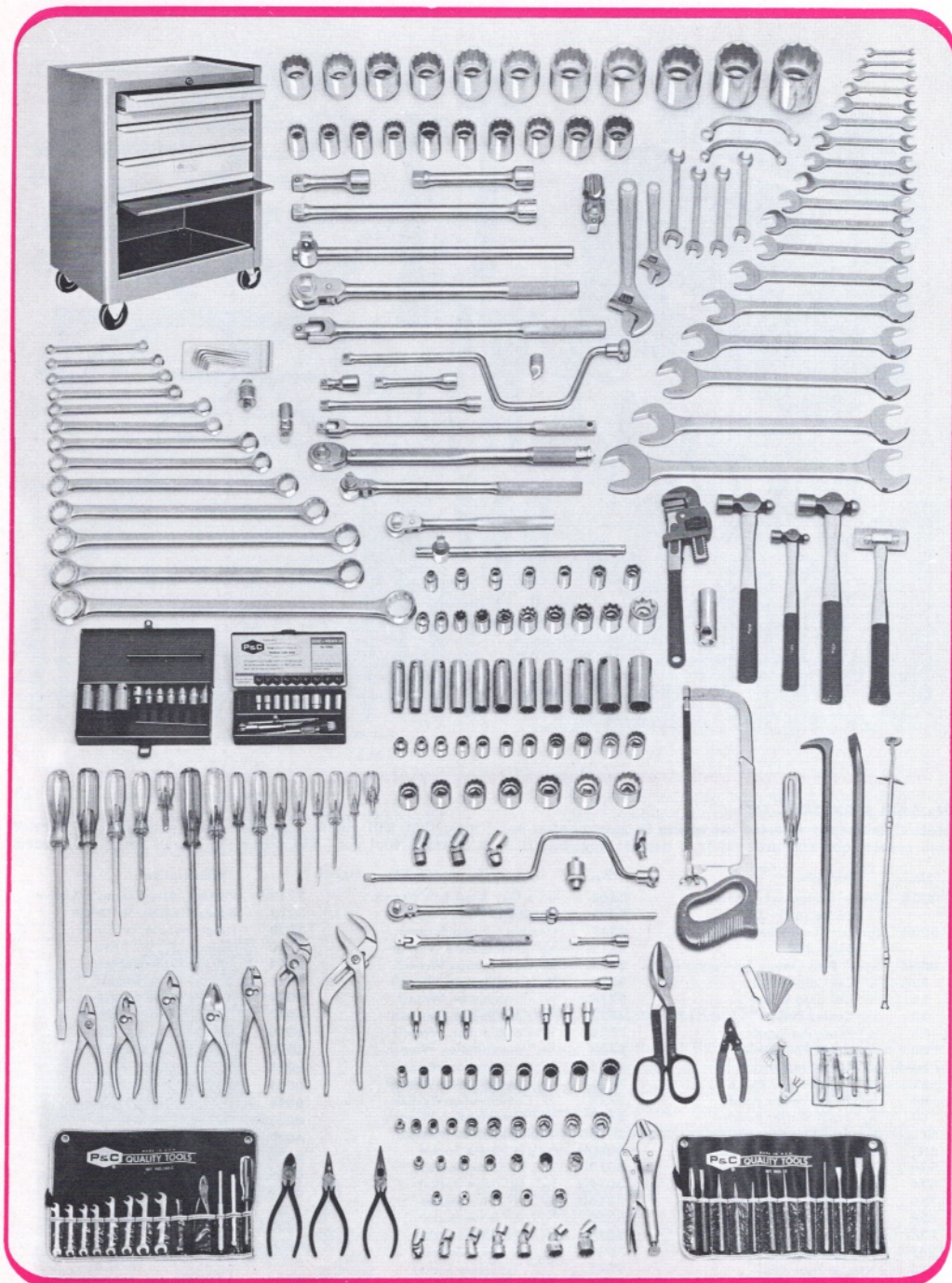

No. 9902-A MAINTENANCE MASTER SET (WITH TOOLMOBILE)

This tool set gives you everything you need for industrial maintenance work. Complete assortment includes 286 quality P&C tools—ideal for factories, railroads, shipyards, refineries, mills, utilities. Use it, too, for repairing automobiles, buses, tractors, trucks, farm machinery, aircraft, construction equipment. Toolmobile provides handy, orderly storage for complete tool set.

The tools in this Master Maintenance set have been carefully selected by practical, practicing maintenance mechanics to assure you everything needed to get the majority of jobs done with speed and ease. No needless, seldom used tools. No gadgets or single purpose equipment. From pullers to pliers, from sockets to screwdrivers, from grab-all to gauge you'll find these the finest quality you can ever buy... and the best way to get the job done.

P&C MASTER SET — NO. 9902-A Wt. 302 lbs.

No.	Description	No.	Description
000A	Feeler Gauge Set	2516	$\frac{3}{16}$ " x $\frac{1}{2}$ " Box Wrench
000K	Spark Plug Gauge Set	2518	$\frac{1}{2}$ " x $\frac{9}{16}$ " Box Wrench
2	12-Piece Punch and Chisel Set	2520	$\frac{3}{16}$ " x $\frac{3}{8}$ " Box Wrench
102	Lining Up Bar	2524	$\frac{3}{8}$ " x $\frac{3}{4}$ " Box Wrench
140C	13-Piece Ignition Set	2525	$\frac{1}{8}$ " x $\frac{3}{4}$ " Box Wrench
0200C	$\frac{1}{4}$ " Socket Set	2528	$\frac{3}{4}$ " x $\frac{7}{8}$ " Box Wrench
464	$\frac{1}{8}$ " x 4" Cabinet Screwdriver	2529	$\frac{13}{16}$ " x $\frac{7}{8}$ " Box Wrench
473	No. 0 Phillips Screwdriver	2532	$\frac{15}{16}$ " x 1" Box Wrench
504	$\frac{3}{16}$ " x 4" Blade Screwdriver	2536	$\frac{1}{8}$ " x $\frac{11}{16}$ " Box Wrench
566	$\frac{3}{16}$ " x 6" Cabinet Screwdriver	2542	$\frac{1}{4}$ " x $\frac{13}{16}$ " Box Wrench
573	No. 1 Phillips Screwdriver	2544	$\frac{1}{4}$ " x 1 $\frac{3}{8}$ " Box Wrench
601	$\frac{1}{4}$ " x 1 $\frac{1}{2}$ " Blade Screwdriver	2548	$\frac{1}{8}$ " x 1 $\frac{1}{2}$ " Box Wrench
604	$\frac{1}{4}$ " x 4" Blade Screwdriver	2810	$\frac{1}{4}$ " x $\frac{5}{8}$ " Open End Wrench
669	$\frac{1}{4}$ " x 10" Cabinet Screwdriver	2812	$\frac{3}{16}$ " x $\frac{3}{8}$ " Open End Wrench
670	No. 2 Stubby Phillips Screwdriver	2814	$\frac{3}{8}$ " x $\frac{3}{4}$ " Open End Wrench
674	No. 2 Stubby Phillips Screwdriver	2816	$\frac{7}{16}$ " x $\frac{1}{2}$ " Open End Wrench
706	$\frac{3}{16}$ " x 6" Blade Screwdriver	2818	$\frac{1}{2}$ " x $\frac{9}{16}$ " Open End Wrench
776	No. 3 Phillips Screwdriver	2820	$\frac{9}{16}$ " x $\frac{3}{8}$ " Open End Wrench
808	$\frac{3}{8}$ " x 8" Blade Screwdriver	2821	$\frac{19}{32}$ " x $\frac{11}{16}$ " Open End Wrench
812	$\frac{3}{8}$ " x 12" Blade Screwdriver	2822	$\frac{3}{8}$ " x $\frac{11}{16}$ " Open End Wrench
878	No. 4 Phillips Screwdriver	2824	$\frac{3}{8}$ " x $\frac{3}{4}$ " Open End Wrench
1202	Thin Jaw Pliers	2825	$\frac{13}{16}$ " x $\frac{3}{4}$ " Open End Wrench
1203	Bent Jaw Pliers	2828	$\frac{3}{4}$ " x $\frac{7}{8}$ " Open End Wrench
1206	6" Diagonal Pliers	2829	$\frac{13}{16}$ " x $\frac{7}{8}$ " Open End Wrench
1225	Curved Needle Nose Pliers	2832	$\frac{15}{16}$ " x 1" Open End Wrench
1226	Needle Nose w/Cutter	2836	$\frac{1}{8}$ " x $\frac{11}{16}$ " Open End Wrench
1243	10" Power Track Pliers	2840	$\frac{13}{16}$ " x 1 $\frac{1}{4}$ " Open End Wrench
1246	6" Combination Pliers	2842	$\frac{1}{4}$ " x $\frac{13}{16}$ " Open End Wrench
1248P	Plumbing Pliers	2846	$\frac{13}{16}$ " x $\frac{1}{16}$ " Open End Wrench
1252A	Hose Clamp Pliers	2852	$\frac{1}{2}$ " x $\frac{13}{16}$ " Open End Wrench
1278	8" Slip Joint Pliers	3000A	Hollow Head Screw Socket Set
1291R	Lever Wrench Pliers	3000GG	$\frac{3}{8}$ " Drive Socket Set
1299	Wire Stripper	3752	$\frac{3}{16}$ " Flare Nut Wrench
1320	10" Snips	3753	$\frac{1}{2}$ " Flare Nut Wrench
1361	Hacksaw	3754	$\frac{3}{16}$ " Flare Nut Wrench
1383	Plastic Tip Hammer	3755	$\frac{3}{8}$ " Flare Nut Wrench
1708L	8" Adjustable Wrench	4977	Hex Key Set
1712L	12" Adjustable Wrench	6000D	$\frac{1}{2}$ " Drive Socket Set
1725	$\frac{7}{16}$ " x $\frac{1}{2}$ " Obstruction Wrench	6316	$\frac{1}{2}$ " Drive Torque Wrench
1730	$\frac{3}{16}$ " x $\frac{3}{8}$ " Obstruction Wrench	8604	4 oz. Hammer
1814	14" Pipe Wrench	8612	12 oz. Hammer
2126	16" Rolling Head Bar	8616	1 lb. Hammer
2336	Gasket Scraper	9300AA	$\frac{3}{4}$ " Drive Socket Set
2344	17 $\frac{1}{2}$ " Grab-all	9500A	Screw Extractor Set
2514	$\frac{3}{8}$ " x $\frac{7}{16}$ " Box Wrench	9960	Toolmobile Cabinet

Set Includes Mobile Storage Cabinet

Toolmobile cabinets save time on the job, help eliminate costly tool losses. Drawers and trays are partitioned, make it easy to find the right tool. All parts made of heavy gauge steel, electrically welded, reinforced for rugged use, long life. Attractively finished in rocket red, and mechanics gray. Big 4" true tracking casters roll smoothly over rough surfaces. Full stop easy slide drawer suspensions, removable for cleaning. Hide-a-way panel locks along with drawers providing maximum protection.

Overall size: 26 $\frac{1}{2}$ " x 18" x 32 $\frac{1}{2}$ ". Weight: Chest only—104 lbs.

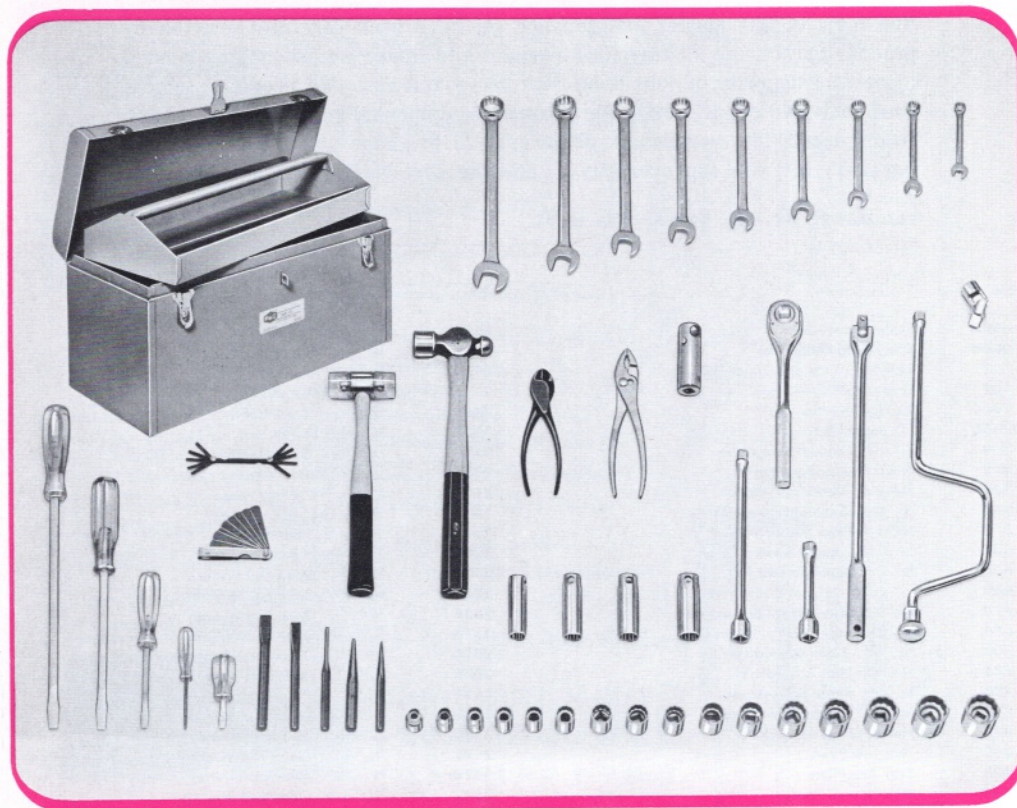

No. 9914 APPRENTICE TOOL SET

With this 52-piece tool set, you can handle most service jobs. Low initial investment. Then from this base you can build a complete mechanic's tool set tool by tool while you work! Nothing to throw away . . . you just add to your efficiency with more of the right tools for the job.

No.	DESCRIPTION	No.	DESCRIPTION	No.	DESCRIPTION
000A	Feeler Gauge Set—9 short blades, .003 - .018	2716	1/2" Combination Wrench	6030	1 3/16", 1/2" Drive Socket
000D	Ignition Gauge Set—10 blades, .013 - .040	2718	3/8" Combination Wrench	6032	1", 1/2" Drive Socket
11	3/8" Cut Cold Chisel	2720	3/8" Combination Wrench	6034	1 1/8", 1/2" Drive Socket
13	3/8" Cut Cold Chisel	2722	1 1/8" Combination Wrench	6036	1 1/8", 1/2" Drive Socket
22	3/8" Center Punch	2724	3/4" Combination Wrench	6040	1 1/4", 1/2" Drive Socket
63	3/8" Point, Pin Punch	2726	1 3/8" Combination Wrench	6120	3/8", 1/2" Drive, Deep Socket
67	3/8" Point, Starter Punch	2728	7/8" Combination Wrench	6122	1 1/8", 1/2" Drive, Deep Socket
442	1/8" x 2 1/2" Blade Screwdriver	4515	Stud Remover	6124	3/4", 1/2" Drive, Deep Socket
601	1/4" x 1 1/2" Blade Screwdriver	6012	3/8", 1/2" Drive Socket	6126	1 3/8", 1/2" Drive, Deep Socket
604	1/4" x 4" Blade Screwdriver	6014	7/16", 1/2" Drive Socket	6203	5" Extension, 1/2" Drive
808	3/8" x 8" Blade Screwdriver	6016	1/2", 1/2" Drive Socket	6205	10" Extension, 1/2" Drive
812	3/8" x 12" Blade Screwdriver	6018	9/16", 1/2" Drive Socket	6208	Universal Joint, 1/2" Drive
1209	Diagonal Cutting Pliers	6019	1 1/2", 1/2" Drive Socket	6210	Ratchet, Reversing, 1/2" Drive
1278	8" Slip Joint Pliers	6020	3/8", 1/2" Drive Socket	6215	Speed Handle, 1/2" Drive
1383	Plastic Tip Hammer	6022	1 1/4", 1/2" Drive Socket	6238	18" Hinge Handle, 1/2" Drive
2712	3/8" Combination Wrench	6024	3/4", 1/2" Drive Socket	8616	1 lb. Ball Pein Hammer
2714	7/16" Combination Wrench	6025	25/32", 1/2" Drive Socket	D-1120	20" x 8 1/2" x 9 3/4" Metal Box
		6026	1 3/8", 1/2" Drive Socket		
		6028	7/8", 1/2" Drive Socket		

Total weight of set . . . 31.30 lbs.

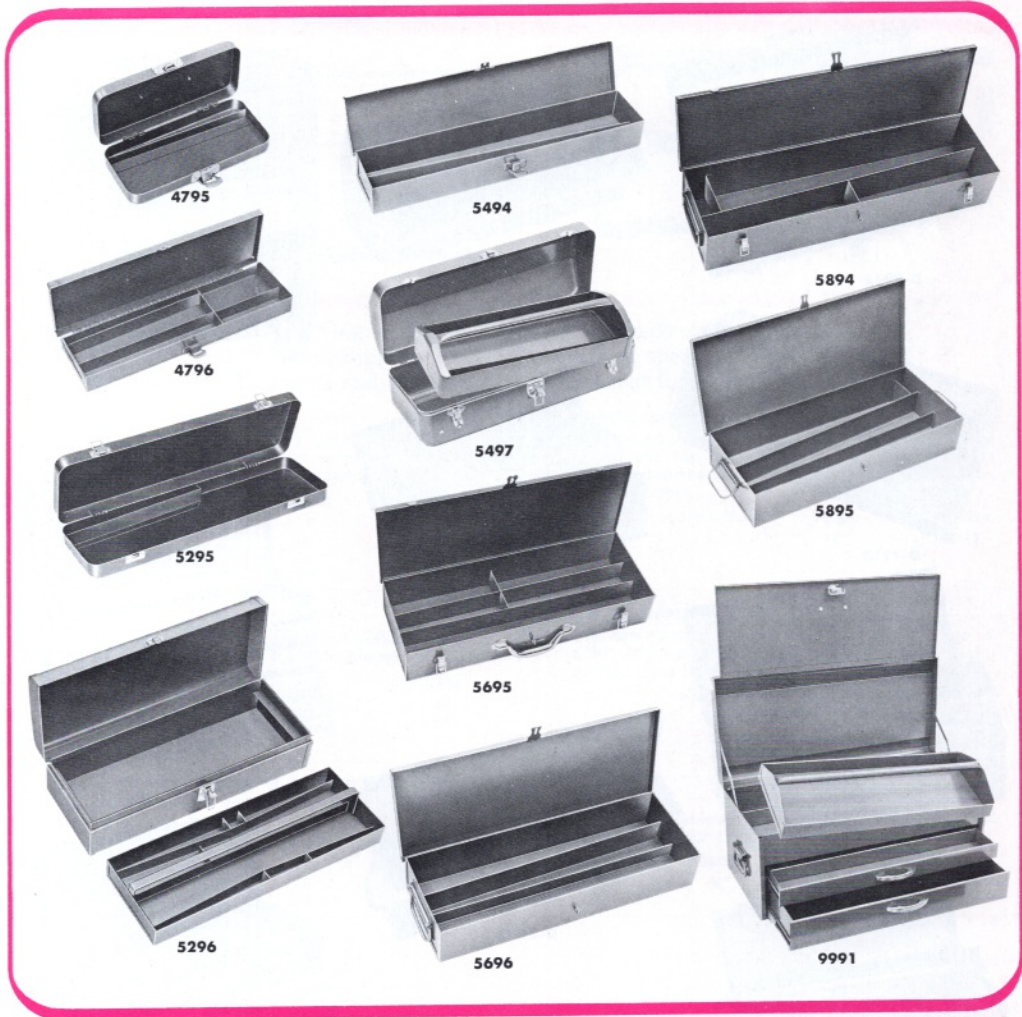

P&C Tool Boxes, Chests and Cabinets are designed by men who use them every day. Forming is precise, joints are tight and smooth, welds will not give way, handles are smooth for ease in carrying and finishes are baked on for years of lasting under the toughest of usage. From hasp to hinge, P&C Boxes are the professional's choice.

No.		Length	Width	Depth	Wt. Lbs.
4795	Just the thing for small parts like 1/4" drive sockets and attachments.	6 3/4"	3"	1 1/4"	.52
4796	A quality box with tapered compartment for sockets, room for more.	12"	3 1/2"	1 1/8"	1.16
5295	Has sturdy hinge and sure-hold catch. Just the size for 3/8" drive.	17 1/4"	5 1/4"	1 1/2"	1.70
5296	Capacity for 3/8" drive and more. Rounded corners and deep top.	19"	7"	4 3/4"	9.00
5494	Holds large number of 1/2" drive sockets plus associated tools.	16 1/4"	3"	2"	1.86
5497	A beauty. Rounded corners, easy-carry handle, full piano hinge.	18 3/4"	7 1/4"	6"	7.00
5695	For 3/4" drive sockets and attachments. Has 2 spring catches and hasp.	22 1/8"	8"	3 3/4"	9.00
5696	Big and heavy duty for 3/4" drive plus many other tools. Handle on end.	23 1/2"	9 1/4"	4"	19.50
5894	Extra heavy duty for the biggest of sets. Reinforced, riveted.	30"	8 3/4"	5"	13.60
5895	Made just like the previous box but has more capacity.	30"	12 1/2"	5 1/2"	37.00
9991	For master sets. Has tote tray, divided top section, 2 big drawers.	26"	12"	11 3/4"	34.00

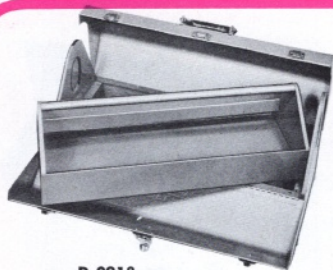

D-0918



D-1121



D-1216

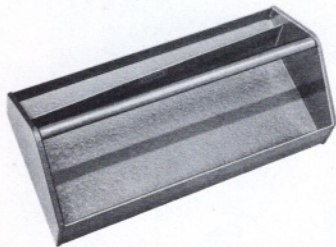

D-1113



D-1123



D-1225

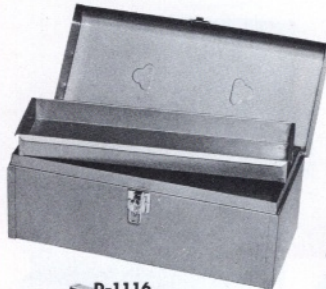

D-1116

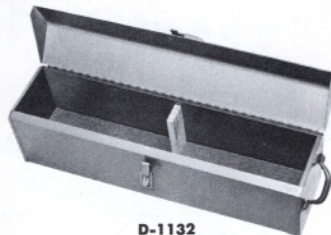

D-1132

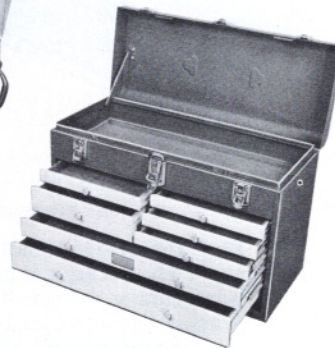

D-1250

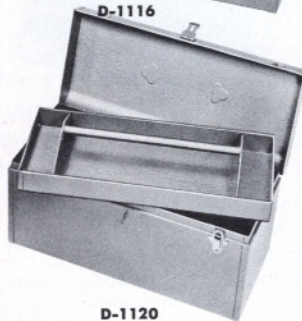

D-1120

No.		Length	Width	Depth	Wt. Lbs.
D-0918	Large tool compartment plus tote tray. Full length hinge.....	19"	10"	13"	16.50
D-1113	Has big capacity with socket section. Handle rolled steel.....	19"	9 $\frac{1}{8}$ "	3"	3.75
D-1116	Has removable tote tray and big storage space. Full length hinge.....	16"	7"	7"	6.00
D-1120	Handles a big assortment. Full length hinge, hasp and catches.....	20"	8 $\frac{1}{2}$ "	9 $\frac{5}{8}$ "	11.50
D-1121	Spill-proof design easy to carry, open and use. Tote tray included.....	21"	8 $\frac{1}{2}$ "	7 $\frac{1}{2}$ "	10.00
D-1123	Cantilever tray type that is easy to use. Sturdy with big capacity.....	19"	7"	7"	6.50
D-1132	Popular hip design. Has clips to hold level, block for saws.....	32 $\frac{1}{4}$ "	8"	9 $\frac{3}{4}$ "	12.00
D-1216	The best of roller cabinets. Cover gives complete safety.....	26 $\frac{3}{8}$ "	18"	32 $\frac{1}{2}$ "	86.00
D-1225	The best of cabinets. Matches roller cabinet above for a set.....	26"	12"	14 $\frac{3}{8}$ "	54.50
D-1250	For use with precision tools. Drawers lined with green flock.....	20 $\frac{1}{8}$ "	8 $\frac{1}{2}$ "	13 $\frac{1}{2}$ "	31.50

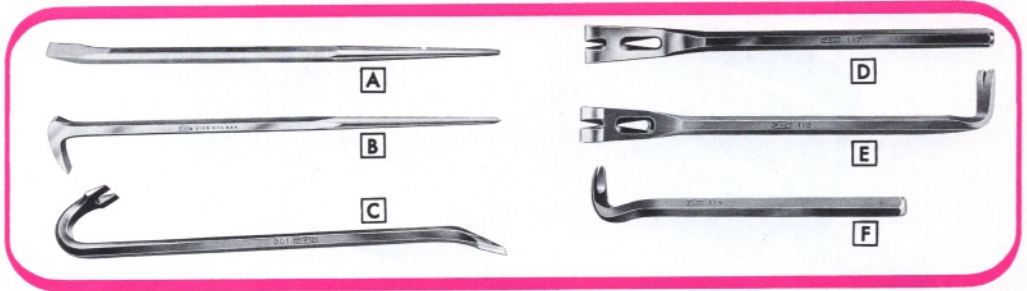

When you have a prying or ripping job to do, you need strength and leverage. These P&C Bars and Ripping Chisels are made of special analysis steel, hot forged for toughness and scientifically heat treated for extra strength.

A LINING-UP BARS

Working easily for prying and aligning jobs. Prying end designed for optimum leverage, tapered end has long slim taper for increased utility.

No.	Stock Size	Length	Wt. Lbs.
101	1/2"	14"	.65
102	5/8"	18"	1.33
103	3/4"	24"	2.55
104	15/16"	30"	5.50

B ROLLING HEAD BARS

A functional design idea with a 90° rolling head. Just the thing for getting into tight places.

No.	Stock Size	Length	Wt. Lbs.
2126	1/2"	16"	.86
2130	3/8"	18"	1.62

C WRECKING BARS

Have long, fully polished chisel point on the pry end. Nail puller end has half polished, deep-bevel nail claw.

No.	Stock Size	Length	Wt. Lbs.
105	3/8"	18"	2.15
106	3/4"	24"	3.63
108	3/4"	30"	4.50

D RIPPING CHISEL

For use where the work is speeded by having the ripper and the nail puller on the same end. Has heat-treated shank end, fully polished chisel blade, dual nail slots.

No.	Stock Size	Length	Wt. Lbs.
117	3/4"	18"	2.17

E OFFSET RIPPING CHISEL

The same as No. 117 plus additional advantage of a 90° offset claw. Heat treated to withstand hammering. Has triple nail slots.

No.	Stock Size	Length	Wt. Lbs.
118	3/4"	18"	2.48

F NAIL PULLER

Two or three blows of a hammer firmly seats this handy puller for the toughest of nail pulling jobs.

No.	Stock Size	Length	Wt. Lbs.
119	5/8"	10 1/2"	1.16

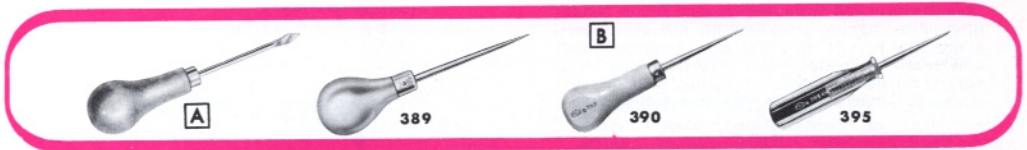

P&C Awls are designed for maximum utility. Points are of hardened steel to resist bending and hold the point. Handles are of highest grade hardwood or toughest plastic and are designed to fit the palm comfortably. Point and handle are bonded together for a lifetime of use.

A TIRE PRODDING AWL

Designed to remove imbedded particles from automobile tires without damaging the tube. Tapered blade spreads rubber.

No.	Length	Wt. Lbs.
230	7 1/4"	.10

B GENERAL PURPOSE AWLS

A variety of lengths and handle designs to choose from. Wooden handles have nickel plated ferrule for protection.

No.	Length	Wt. Lbs.
389	4 7/8"	.06
390	6 1/2"	.12
395	6 1/2"	.14



A

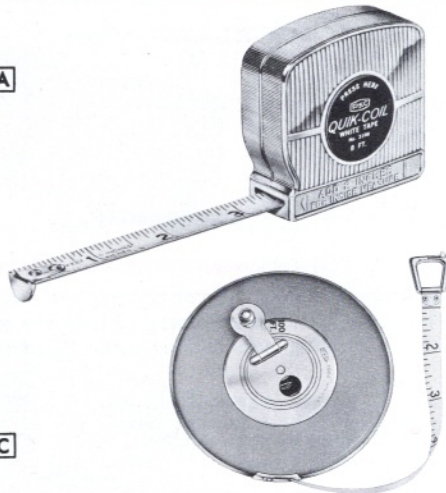

B

D

Tapes that are easy to read and easy to use carry the P&C name. All push-pull and power tapes have 2" cases for easy inside measuring. Blades are replaceable, have clear markings and are bonderized for years of heavy use.

A PUSH-PULL TAPES

In beautiful chrome plated metal case. Tape is tempered steel with white bonderized enamel finish and black, easy-to-read foot and inch markings. Self-adjusting end hook permits inside and outside measurements. Blade easily replaced. Comes complete with free belt hook.

No.	Type	Blade Width	Blade Length	Wt. Lbs.
1949	Push-Pull	1/2"	6'	.30
1950	Push-Pull	1/2"	8'	.33
1951	Push-Pull	1/2"	10'	.35
1952	Push-Pull	1/2"	12'	.38
1953	Push-Pull	3/4"	12'	.54
2026	Push-Pull	3/4"	10'	.52

D STEEL LONG TAPES

Tape is 3/8" white finished steel with clear inch and foot markings. Throat has double throat rollers. Flush folding rewind handle. Hook ring included at end of blade. Case is zinc plated steel covered with attractive vinyl fabric.

No.	Length	Wt. Lbs.
1961	50 ft.	.75
1962	100 ft.	1.13

REPLACEMENT BLADES

Wound in reverse for easy replacement. Universal type that fits most makes of tapes of power and push-pull type.

No.	Fits P&C Tape No.	Blade Width	Blade Length
1949-R	1949	1/2"	6'
1950-R	1950 & 1954	1/2"	8'
1951-R	1951 & 1955	1/2"	10'
1952-R	1952 & 1956	1/2"	12'
1953-R	1953 & 1957	3/4"	12'
2026-R	2026 & 2027	3/4"	10'

B POWER TAPES

Gives you positive control of blade return with smooth action and no dangerous snap action. Nylon internal mechanism gives long life and quiet operation. Has heavily chromed case, tempered and bonderized white steel blade. Giant size end hook adjusts for inside-outside measuring. Blades easily changed. Comes complete with free belt hook.

No.	Type	Blade Width	Blade Length	Wt. Lbs.
1954	Power	1/2"	8'	.44
1955	Power	1/2"	10'	.46
1956	Power	1/2"	12'	.47
1957	Power	3/4"	12'	.60
2027	Power	3/4"	10'	.58

C NARROW PUSH-PULL TAPES

Thin, slim-line design makes this tape handier for pocket and purse. Same accurate measure and ease of reading.

No.	Type	Blade Width	Blade Length	Wt. Lbs.
2020	Push-Pull	1/4"	6'	.16
2021	Push-Pull	1/4"	8'	.25
2022	Push-Pull	1/4"	10'	.30



Makes
Tape-Rule
display
easy

Look for this carded P&C
Tape Rule. It tells the
entire tape story.

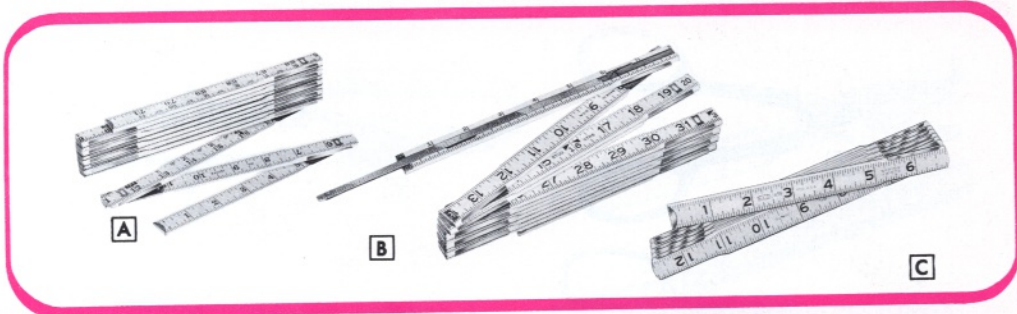

A HEAVY DUTY FOLDING RULE
 Made of select hardwood with triple-coat white enamel finish. Has 6" folds for greatest convenience in use. Brass plated steel spring joints and brass strike plates to protect markings. Graduated in inches and feet and inches for quick reading.

No.	Type Reading	Width	Length	Wt. Lbs.
1959	Outside	5/8"	6'	.25
1960	Inside	5/8"	6'	.25

C ECONOMY FOLDING RULE
 A real utility rule. Has coil spring joints and strike plates to protect markings. Made of seasoned hardwood and multiple coated with clear figures and accurate markings.

No.	Type Reading	Width	Length	Wt. Lbs.
1958	Outside	5/8"	6'	.25
1958-I	Inside	5/8"	6'	.25

B HEAVY DUTY EXTENSION RULE
 Made to the same rigid specifications as P&C No. 1959 and 1960 but has 6" long brass extension that makes possible measurements inside door jams and the like. Can also be used as a depth gauge. Natural boxwood finish.

No.	Type Reading	Width	Length	Wt. Lbs.
1960-E	Outside	5/8"	6'	.38



P&C Rules Packaged
 with Handy Hang-Up
 Sleeves for easy display

UTILITY KNIVES

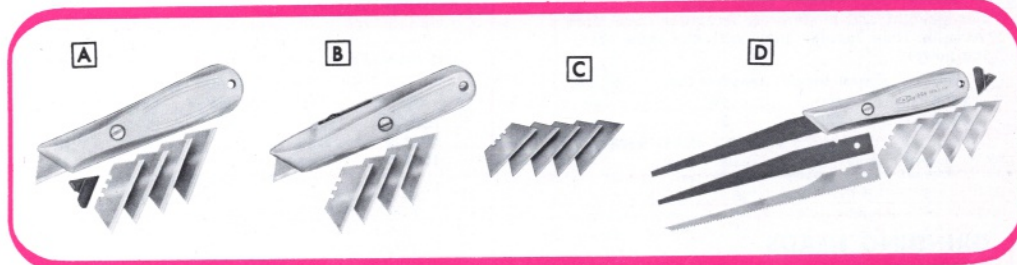

This is the handy successor to the pocket knife in the average shop. Has a thousand uses from opening cartons to cutting flooring materials and wallboards. P&C Utility blades are of finest tool steel sharpened to a razor edge.

A REPLACEABLE BLADE KNIFE
 Comes with five No. 1691 blades stored in the handle. All metal and shaped to fit the hand. Hang-up hole in handle and metal knife guard included.

No.	Description	Wt. Lbs.
1690	Knife with five blades	.25

C REPLACEMENT BLADES
 Sharp, long-lasting replacement blades for both styles of P&C Utility Knife. Notched to fit all popular styles of knives.

No.	Description	Wt. Lbs.
1691	Pkg. of 5 Standard Blades	.04
1692	Pkg. of 5 Heavy Duty Blades	.05
1691-X	Pkg. of 100 Standard Blades	.7
1692-X	Pkg. of 100 Heavy Duty Blades	.9

B PUSHBUTTON SLIDE-LOCK KNIFE
 Provides instant fingertip positioning to four positions for maximum safety and efficiency in use. Comes with five heavy duty alloy steel blades, No. 1692. Extra blades store in the handle.

No.	Description	Wt. Lbs.
1693	Slide-Lock Knife with five blades	.25

D SAW-KNIFE SET
 A complete utility knife and a set of handy saws all in one unit. Knives and saw blades are quickly interchangeable. Set consists of P&C No. 1690 handle with five blades plus No. 1966-M 18-tooth metal-cutting saw, No. 1966-N 24-tooth metal-cutting saw and 1966-W 9-tooth wood cutting saw.

No.	Description	Wt. Lbs.
1694	Saw-Knife Set	.42

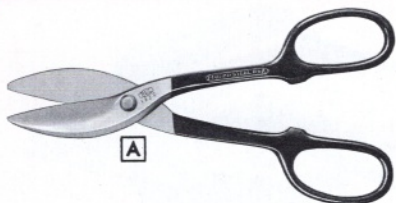

A



C

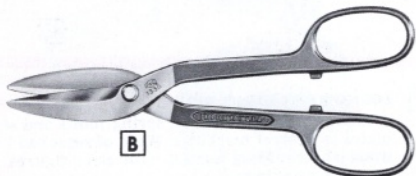

B

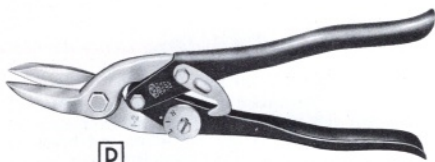

D

With P&C Snips you get fast, smooth cuts in sheet metal, sheet brass, copper, plastic cloths and many other materials. Blades are hot drop forged from special analysis steel and electrically heat treated to provide long-wearing toughness. Pivot screws are tightened precisely for the best cut without binding and then locked in that position. Blades give uniform shearing with minimum metal distortion. Handles are hand contoured.

A STRAIGHT OR REGULAR

Will handle all kinds of cutting jobs. Gives lots of shearing power.

No.	Overall Length	Length of Cut	Wt. Lbs.
1317	7"	1¾"	.38
1320	10"	2½"	.86
1322	12"	3"	1.50

C DUCKBILL OR CIRCULAR

For cutting circles and other curved designs. Blades hollow ground for better work.

No.	Overall Length	Length of Cut	Wt. Lbs.
1307	7"	1¾"	.38
1310	10"	2½"	.84
1312	12"	3"	1.46

B COMBINATION PATTERN

For straight and moderately irregular cuts. More versatile than regular snips with the same shearing power.

No.	Overall Length	Length of Cut	Wt. Lbs.
1330	10"	2½"	.88
1332	12"	3"	1.46

D MULTIPLE LEVERAGE

Aviation type with compound action that greatly increases shearing power. Available in straight cut, left cut and right cut.

No.	Type Cut	Overall Length	Length of Cut	Wt. Lbs.
1303-L	Left	9¾"	1½"	.70
1303-R	Right	9¾"	1½"	.70
1303-S	Straight	9¾"	1½"	.72

GRINDING HEADS

P&C Grinding Heads are cast of alloy metal and then machined with care and skill to assure years of vibration-free, smooth, true running. The ½" steel spindle runs in oil-impregnated bearings. Bearings are each 1¼" long to give strength and rigidity. The V-belt pulley can be run from above, below, or from either side. Height to center of spindle is 6".

A DOUBLE HEAD

Has two sets of flanges for ¾" face wheels up to 4" in diameter. Handles wheels with ½" diameter.

No.	Wt. Lbs.
1656	5.00

B COMBINATION HEAD

Has longer spindle on right side with a 0-¾" capacity three-jawed chuck. Can be used for drilling and other chores. Spindles are ½" in diameter and threaded 20 to the inch.

No.	Wt. Lbs.
1657	5.63

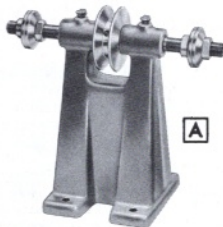

A

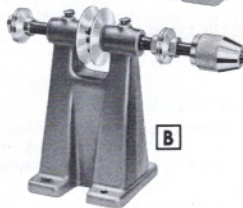

B

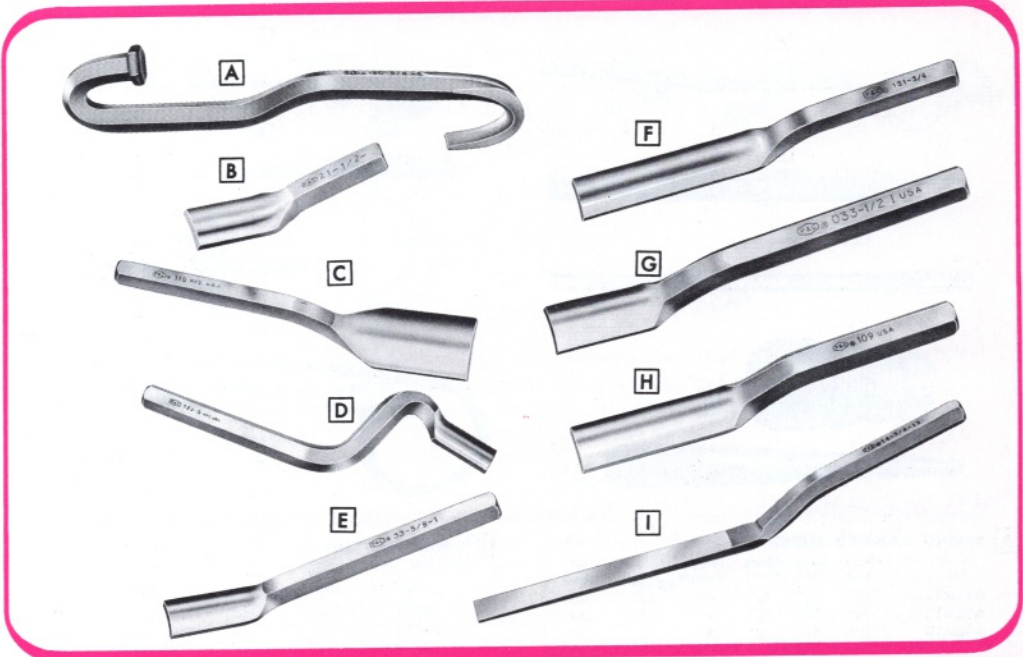

A CEILING CALKER

No.	Stock Size	Blade Thickness	Blade Width	Blade Length	Overall Length	Wt. Lbs.
130- $\frac{3}{8}$	$\frac{5}{8}$ "	$\frac{5}{32}$ "	$1\frac{1}{16}$ "	1 $\frac{5}{8}$ "	10"	1.20

B CURVED PONY CALKERS (Inside and Outside)

No.	Stock Size	Blade Thickness	Blade Width	Blade Length	Overall Length	Wt. Lbs.
21- $\frac{1}{2}$ In	$\frac{1}{2}$ "	$\frac{1}{8}$ "	$\frac{3}{4}$ "	$1\frac{1}{4}$ "	3"	.13
21- $\frac{1}{2}$ Out	$\frac{1}{2}$ "	$\frac{1}{8}$ "	$\frac{3}{4}$ "	$1\frac{1}{4}$ "	3"	.13

C BROAD CURVED NOSE CALKING IRON

No.	Stock Size	Blade Thickness	Blade Width	Blade Length	Overall Length	Wt. Lbs.
110	$\frac{5}{8}$ "	$\frac{1}{8}$ "	$1\frac{1}{2}$ "	2"	$8\frac{1}{2}$ "	.71

D LEFT AND RIGHT CALKERS

No.	Stock Size	Blade Thickness	Blade Width	Blade Length	Overall Length	Wt. Lbs.
132-L	$\frac{5}{8}$ "	$\frac{5}{32}$ "	$\frac{7}{8}$ "	1 $\frac{5}{8}$ "	8 $\frac{7}{8}$ "	.87
132-R	$\frac{5}{8}$ "	$\frac{5}{32}$ "	$\frac{7}{8}$ "	1 $\frac{5}{8}$ "	8 $\frac{7}{8}$ "	.87

E LONG CALKERS (Inside and Outside)

No.	Stock Size	Blade Thickness	Blade Width	Blade Length	Overall Length	Wt. Lbs.
33- $\frac{1}{2}$ In	$\frac{1}{2}$ "	$\frac{7}{64}$ "	$\frac{3}{4}$ "	$1\frac{1}{2}$ "	$6\frac{1}{2}$ "	.32
33- $\frac{1}{2}$ Out	$\frac{1}{2}$ "	$\frac{7}{64}$ "	$\frac{3}{4}$ "	$1\frac{1}{2}$ "	$6\frac{1}{2}$ "	.32
33- $\frac{3}{8}$ In	$\frac{1}{2}$ "	$\frac{1}{8}$ "	$\frac{7}{8}$ "	$1\frac{3}{4}$ "	7"	.52
33- $\frac{3}{8}$ Out	$\frac{1}{2}$ "	$\frac{1}{8}$ "	$\frac{7}{8}$ "	$1\frac{3}{4}$ "	7"	.52

F LONG GASKET CALKERS

No.	Stock Size	Blade Thickness	Blade Width	Blade Length	Overall Length	Wt. Lbs.
131- $\frac{3}{8}$	$\frac{5}{8}$ "	$\frac{5}{32}$ "	$\frac{7}{8}$ "	4"	$9\frac{1}{2}$ "	.67
131- $\frac{3}{4}$	$\frac{3}{4}$ "	$\frac{3}{16}$ "	1"	$4\frac{3}{4}$ "	$9\frac{1}{2}$ "	.98

G OFFSET CALKERS (Inside and Outside)

No.	Stock Size	Blade Thickness	Blade Width	Blade Length	Overall Length	Wt. Lbs.
033- $\frac{1}{2}$ In	$\frac{1}{2}$ "	$\frac{7}{64}$ "	$\frac{3}{4}$ "	$1\frac{1}{2}$ "	$6\frac{1}{2}$ "	.33
033- $\frac{1}{2}$ Out	$\frac{1}{2}$ "	$\frac{7}{64}$ "	$\frac{3}{4}$ "	$1\frac{1}{2}$ "	$6\frac{1}{2}$ "	.33
033- $\frac{3}{8}$ In	$\frac{5}{8}$ "	$\frac{1}{8}$ "	$\frac{7}{8}$ "	1 $\frac{5}{8}$ "	7"	.57
033- $\frac{3}{8}$ Out	$\frac{5}{8}$ "	$\frac{1}{8}$ "	$\frac{7}{8}$ "	1 $\frac{5}{8}$ "	7"	.57

H WATER MAIN CALKERS

No.	Stock Size	Blade Thickness	Blade Width	Blade Length	Overall Length	Wt. Lbs.
107- $\frac{3}{8}$	$1\frac{1}{8}$ "	$\frac{3}{8}$ "	1"	$1\frac{1}{16}$ "	8"	1.01
107- $\frac{1}{2}$	$1\frac{1}{8}$ "	$\frac{1}{2}$ "	1"	$2\frac{3}{16}$ "	8"	1.04
109	$\frac{3}{4}$ "	$\frac{3}{16}$ "	1"	$3\frac{1}{16}$ "	8"	.83

I OFFSET YARNING IRONS

No.	Stock Size	Blade Thck.	Blade Width	Blade Length	Overall Length	Wt. Lbs.
14 $\frac{1}{2}$ x 12 $\frac{1}{2}$	$\frac{1}{2}$ "	$\frac{1}{16}$ "	$\frac{5}{8}$ "	$6\frac{3}{4}$ "	$12\frac{1}{2}$ "	.52
14 $\frac{3}{8}$ x 13	$\frac{5}{8}$ "	$\frac{3}{32}$ "	$1\frac{1}{8}$ "	$7\frac{1}{4}$ "	13"	.79
14 $\frac{3}{8}$ x 19	$\frac{5}{8}$ "	$\frac{3}{32}$ "	$1\frac{1}{8}$ "	$12\frac{3}{4}$ "	19"	.99
14 $\frac{3}{4}$ x 15	$\frac{3}{4}$ "	$\frac{3}{32}$ "	$\frac{3}{4}$ "	$9\frac{1}{2}$ "	15"	1.18



INTERNAL PIPE WRENCHES

Easy to operate. Just screw mandrel to force tough gripping dogs against interior of broken pipe or close nipples, etc. Then turn with wrench. No hammering to release.

No.	Pipe Size	Overall Length	Spare Set of 3 Jaws No.	Spare Screw No.	Wt. Lbs.
140	$\frac{1}{2}$ "	$3\frac{1}{2}$ "	140-J	140-S	.30
141	$\frac{3}{4}$ "	$3\frac{3}{4}$ "	141-J	141-S	.51
142	1"	4"	142-J	142-S	.57

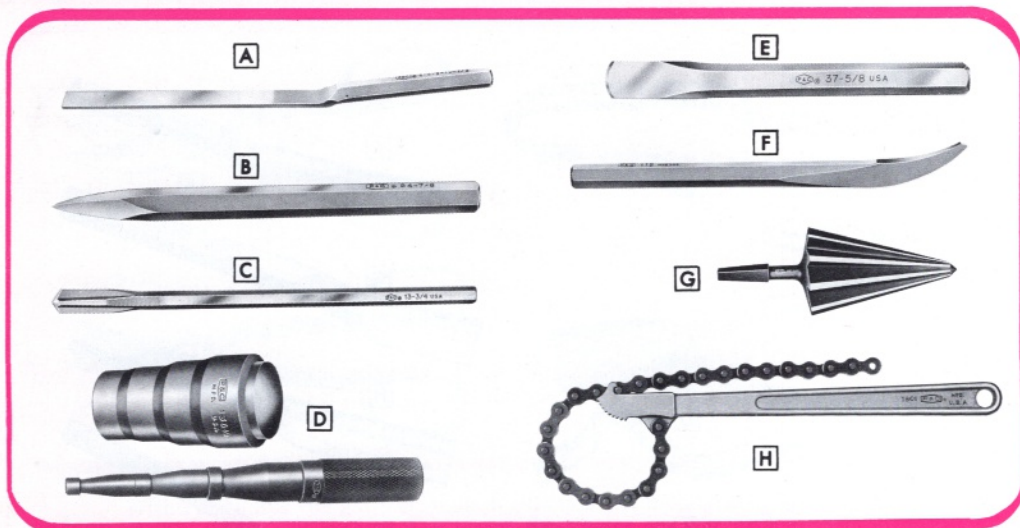
**A SPRING YARNING IRONS**

No.	Stock Size	Blade Thick.	Blade Width	Blade Length	Overall Length	Wt. Lbs.
6 1/2 x 12	1/2"	3/16"	5/8"	6 1/2"	12"	.45
6 3/8 x 12 1/2	5/8"	1/8"	3/4"	7"	12 1/2"	.64
6 3/8 x 18	5/8"	3/32"	3/4"	13"	18"	.80

B CONCRETE GADS

No.	Stock Size	Overall Length	Wt. Lbs.
84 3/4	3/4"	12"	1.40
84 7/8	1 3/16"	12"	1.80
84-1	1 5/16"	12"	2.30

C STAR DRILLS

No.	Stock Size	Drill Tip Diameter	Overall Length	Wt. Lbs.
13 1/4	1/4"	1/4"	12"	.16
13-5/16	1/4"	3/16"	12"	.16
13 3/8	5/8"	3/8"	12"	.26
13 1/2	7/8"	1/2"	12"	.38
13 5/8	7/8"	5/8"	12"	.52
13 3/4	1 1/2"	3/4"	12"	.70
13 7/8	5/8"	7/8"	12"	1.07
13-1	3/4"	1"	12"	1.92

D TUBING EXPANDERS

A handy tool when you have tube to expand. Ruggedly made to take the pounding. Gradual tapers make the job easier.

136-1/2	Handles 1 1/4", 1 3/8" and 1 1/2" Overall length 3 3/8". Wt. .86 lbs.
137-1/2	Handles 3/8", 1/2" and 3/4" Overall length 9". Wt. 1.25 lbs.

E SOIL PIPE CHISELS

No.	Stock Size	Blade Width	Overall Length	Wt. Lbs.
37 1/2	1/2"	5/8"	6 1/2"	.35
37 5/8	5/8"	3/4"	7"	.57
37 3/4	3/4"	7/8"	7 1/2"	.84

F LEAD-PICKING TOOL

No.	Stock Size	Blade Width	Overall Length	Wt. Lbs.
112	1/2"	3/16"	9"	.46

G PIPE REAMERS

The quickest thing you can use to remove burrs from the ends of pipe and tubing. Can also be used to enlarge holes in sheet metal and as a large countersink. Engineered with care and skill from special hardened steel for long life. Has bit brace shank.

No.	Pipe Fit Diameters	Wt. Lbs.
1653	1/8" - 1"	.25
1654	1/4" - 1 1/4"	.50
1655	1/4" - 2"	1.38

H RATCHETING CHAIN WRENCH

Works on all shapes . . . round, square, hexagon, etc. Gives real turning leverage. Handles all sizes from 3/8" to 4". Chain heat treated for strength of 6200 lbs.

No.	Handle Length	Chain Length	Wt. Lbs.
1801	12 1/8"	16 1/4"	1.60

TUBE CUTTING AND FLARING KIT

Everything you need to cut and flare thin wall tubing up to 1 1/8". Cutter has retractable reamer blade and heat-treated, replaceable alloy steel cutting wheel. Also has special flare-cut-off rollers. Flaring tool handles tubing from 3/16" through 5/8". Slip-on yoke is easy opening and closing. Flare forming cone rides on ball bearing. Metal storage box.

No.	Item	Wt. Lbs.
349	Tube Cutting and Flaring Kit, complete With Box No. 4029	3.30
350	Tube Cutter only	.75
351	Tube Flaring Tool only	1.90

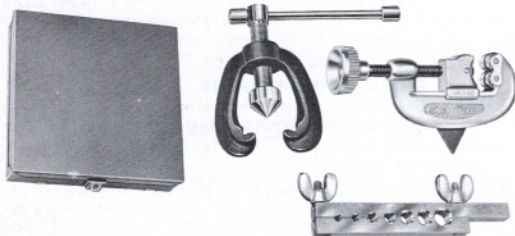

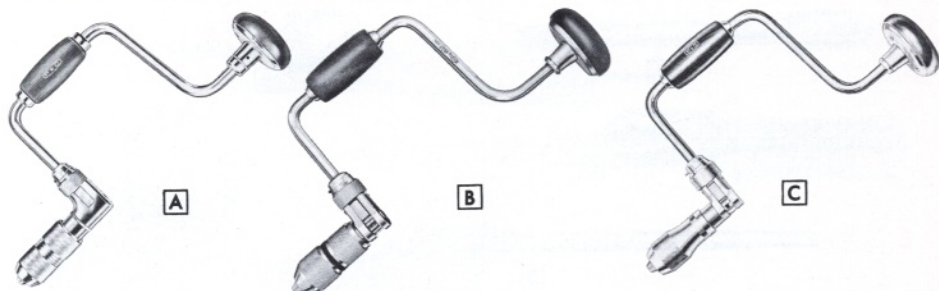

P&C Braces are designed to hold the bit securely, ratchet easily and get the hole making job done with the least effort. Handles are of rich hardwood properly seasoned.

A BOXED RATCHET

The most popular P&C Brace. Has fully enclosed ratcheting mechanism. Holds square and round shanks from $\frac{1}{8}$ " to $\frac{1}{2}$ " diameter. Has new self-centering chuck. All exposed parts nickel plated.

No.	Sweep	Wt. Lbs.
1606	10"	3.50

B SEMI-BOXED RATCHET

This P&C Brace has a Barber chuck with alligator jaws and a semi-boxed steel ratchet. Ratcheting mechanism is controlled by a knurled shifter ring. Head is ball bearing. Exposed parts nickel plated.

No.	Sweep	Wt. Lbs.
1607	10"	2.63

C ECONOMY RATCHET

Does a great job at a popular price. Has Barber chuck and a semi-boxed ratchet operated by a knurled ring shift that works easily.

No.	Sweep	Wt. Lbs.
1608	10"	2.31

Over 17,000 stores display and sell P & C Tools from unique, eye-appealing Self Selling Merchandiser units. It's the easiest way ever devised to select the right tool needed for any job.

BITS AND ACCESSORIES

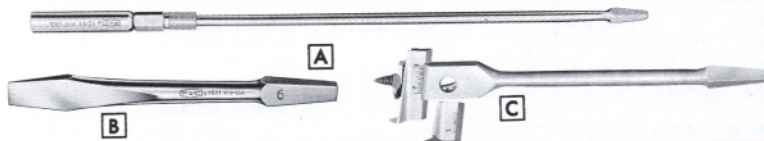
**A BIT EXTENSION**

Get that extra reach when drilling holes. Has one-piece socket and shank construction. Holds bit securely and fits chuck positively. Can be used with $1\frac{1}{16}$ " bit or larger.

No.	Length	Wt. Lbs.
1644	18"	.81

B SCREWDRIVER BITS

The way to drive those tough screws quickly and easily. Hot forged from special steel, then hardened, tempered and polished. Blade tips are carefully engineered to fit the screw slot. Square shanks to fit securely in bit brace chuck. Overall length 5".

No.	Blade Width	Screw Size	Wt. Lbs.
1609	4/16"	6 to 8	.08
1610	5/16"	8 to 12	.10
1611	6/16"	12 to 16	.14

C EXPANSIVE BITS

Clark pattern type. Two cutters for each bit.

No.	Capacity	Wt. Lbs.
1642	$\frac{1}{2}$ " - $1\frac{1}{2}$ "	.25
1643	$\frac{3}{8}$ " - 3"	.50

REPLACEMENT CUTTERS

No.	Capacity
1642A	$\frac{1}{2}$ " - $\frac{3}{8}$ "
1642B	$\frac{3}{8}$ " - $1\frac{1}{2}$ "
1643A	$\frac{3}{8}$ " - $1\frac{3}{4}$ "
1643B	$1\frac{3}{4}$ " - 3"

Every P & C Tool is GUARANTEED against defects in workmanship or materials. You can buy P & C with confidence.

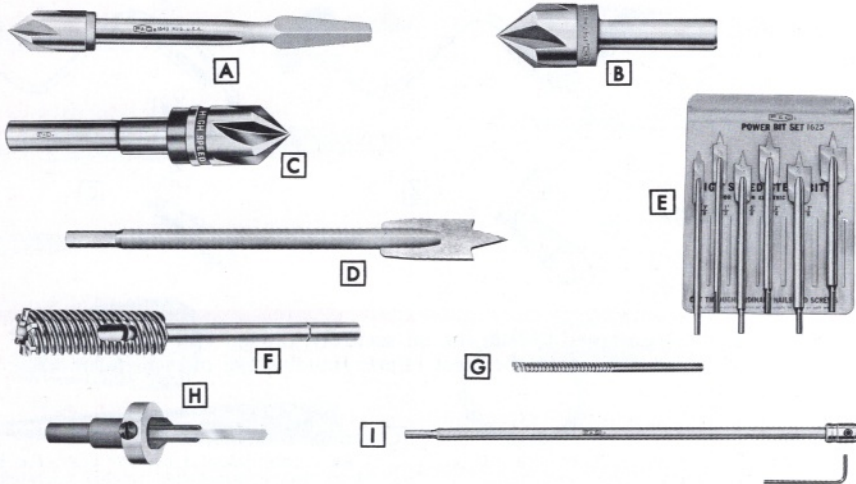
**A COUNTERSINKS**

Do a fast and clean job in wood, non-ferrous metals and even mild steel. Give an 82° countersink that fits the screwhead perfectly. Overall length 4¼".

No.	Diameter	Wt. Lbs.
1648	½"	.10
1649	¾"	.15

B COUNTERSINK — STRAIGHT SHANK

Fits drill presses and hand drills. Does a smooth countersinking job in mild steel, non-ferrous metals, wood, etc. Countersinks at 82° angle.

No.	Description	Wt. Lbs.
1647	¼" shank — ½" body	.04

C COUNTERSINK — HIGH SPEED

Will work in any machinable material. Produces standard 82° angle. Overall length is 2¾".

No.	Description	Wt. Lbs.
1650	¼" shank — ½" body	.06
1651	¼" shank — ¾" body	.09
1652	¼" shank — ¾" body	.12

D HIGH SPEED POWER BITS

The fastest way yet to put holes in hard or soft woods, plastic, plywood or similar materials. Chuck end fits all standard ¼" drills and is flattened to hold fast in regular three-jaw chuck. Shank length permits full cut to 5" depth.

No.	Hole Diameter	Shank Diameter	Wt. Lbs.
1612	⅜"	¼"	.10
1613	½"	¼"	.10
1614	⅝"	⅜"	.13
1615	¾"	⅜"	.15
1616	¾"	¾"	.17
1617	1"	¾"	.19

E POWER BIT SET

All the above sizes of Power Bits in a handy plastic carrying roll. With this set you will always have the bit you need for fast hole drilling in all materials.

No.	Description	Wt. Lbs.
1625-B	Set of 6 Power Bits	.88

MASONRY DRILLS — CARBIDE POWER TYPE

For fast, accurate drilling of concrete, tile, brick, slate, marble, rock, stone, plastic, glass, steel, plaster, asphalt, mica, etc. Sharp tungsten carbide cutters and three or more spirals.

F HOLLOW CORE TYPE

No.	Hole Size	Shank Diameter	Overall Length	Wt. Lbs.
12-5/8	⅝"	¾"	8"	.24
12-3/4	¾"	¾"	8½"	.32
12-7/8	⅞"	½"	9"	.54
12-1	1"	½"	9"	.60
12-1-1/8	1⅛"	½"	10"	.78

G SOLID SHAFT TYPE

No.	Hole Size	Shank Diameter	Overall Length	Wt. Lbs.
11-3/16	⅜"	⅜"	4"	.03
11-1/4	¼"	¼"	5"	.06
11-5/16	⅜"	¼"	5"	.06
11-3/8	⅜"	¼"	5"	.09
11-7/16	⅞"	¼"	5"	.11
11-1/2	½"	¼"	6"	.18

H SCREW GUIDES

The easiest way ever to put screws into wood. Works with either hand or power drills. Drills the pilot hole, gives a larger hole for the screw body and provides a countersink all in one operation. Can also be set to provide for hole plug. Easily adjustable to handle screws of all lengths. This one tool replaces a whole set of other makes that do this job with less efficiency.

No.	Size Screw Handled	Wt. Lbs.
1630	#6 (also 5 and 7)	.12
1631	#8 (also 7 and 9)	.12
1632	#10 (also 9 and 11)	.12
1633	#12 (also 11 and 13)	.12

I POWER BIT EXTENSION

Gives real long reach when used with P&C Power Bits (Nos. 1612 to 1617). Takes all sizes and will "follow through" when used with ¾" or larger. Comes with hex key.

No.	Length	Wt. Lbs.
1635	12"	.53

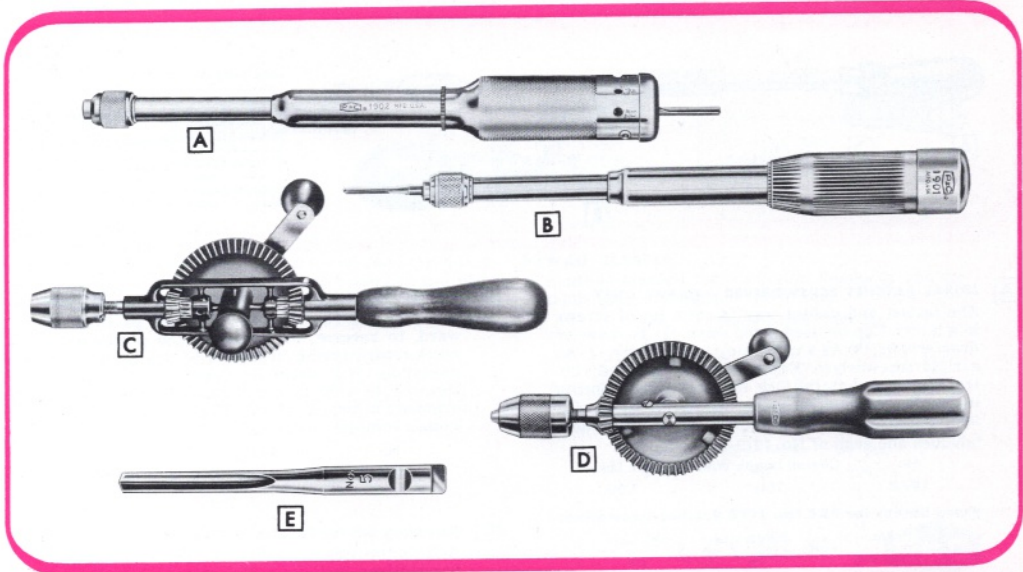

Under the P&C label you find the most popular and usable drills in both the hand and automatic push type. It is easy to select the one best suited for the job at hand. Each drill is engineered with care. The chucks, gears, pinions, cranks and handles all combine to make for ease in use and speed in getting the job done.

A DELUXE AUTOMATIC PUSH DRILL
 This is a smooth working all metal drill with years of built-in useage. Constructed of hollow brass tubes with a machined spiral running through a hard bronze center nut. Has quick-action chuck released by a slight forward pressure of the thumb. Hand-easy handle has interior drill storage for eight drill points and is indexed. Drill is finished in polished and buffed nickel. Comes complete with eight drill points in sizes from 1/16" to 11/64".

No.	Length	Wt. Lbs.
1902	10"	.63

B POPULAR AUTOMATIC PUSH DRILL
 Works easily and smoothly. Has new quick-action chuck that locks or releases drills with a slight thumb pressure. The plastic handle of unbreakable Tenite II has four interior compartments for handy drill storage. Cap is of polished aluminum that fits the palm of the hand. Comes with four drills in sizes 5/64", 7/64", 9/64" and 11/64".

No.	Length	Wt. Lbs.
1901	10"	.50

C SUPERIOR HAND DRILL
 This is a sturdy, double pinion hand drill that works smoothly and without jerks or jamming. Hardwood crank and handle are easy to hang on to. Extra handle at crank shaft adds to versatility. Frame is of sturdy, die-cast zinc. Pinions are of steel. Three-jawed chuck with protected springs holds drills up to 1/4". All metal parts nicked to resist rust.

No.	Capacity	Length	Wt. Lbs.
1683	0 to 1/4"	12 1/2"	1.75

D POPULAR HAND DRILL
 A solid steel frame drill with dependable service built into it. Solid steel pinion and machine-cut teeth for smoother operation. Handles are easy on the hands and are of selected hardwood. Three-jawed chuck handles round shanked drills between 0 to 1/4".

No.	Capacity	Length	Wt. Lbs.
1682	0 to 1/4"	11"	1.38

E DRILL POINTS
 Designed to drill clean holes with ease in wood, soft metal, plastic, wallboard and many other materials. Made of top grade tool steel carefully shaped and sharpened then hardened and tempered. Shank has milled base that gives positive fit in the bottom of the chuck. Notch locks drill in place. Can also be used in standard hand drills.

No.	Size
1905	1/16"
1906	3/32"
1907	1/8"
1908	5/32"
1909	3/16"
1910	7/32"
1911	1/4"
1912	5/16"

DRILL POINT SET
 A complete set of the eight sizes listed above in a screw-capped plastic vial. One of each size for handy useage.

No.	Wt. Lbs.
1915B	.06

P&C Tools Have Been the Choice of Experienced Tool Users for Over 40 Years

70**P&C****SCREWDRIVERS****A****B****C****A SPIRAL RATCHET SCREWDRIVER — HEAVY DUTY**

The fastest and easiest way to set a lot of screws in a hurry. Can be used three ways: (1) To drive or draw screws, (2) As a ratcheting screwdriver, (3) As a rigid screwdriver. Easily adjusted knurled control sleeve and spiral lock nut sets action. Spring in handle automatically positions screwdriver for succeeding strokes . . . permits one-hand operation. Includes one each of No. 1979-C, D, E.

No.	Overall Length With Bit	Wt. Lbs.
1978	20½"	1.50

Extra blades for P&C No. 1978 Ratchet Screwdriver

No.	Blade Size	Wt. Lbs.
1979-C	⅜"	.05
1979-D	¼"	.05
1979-E	⅝"	.05

Phillips Cross-Slot Bits for P&C No. 1978 Ratchet Screwdriver

No.	Phillips Size	Wt. Lbs.
1980	No. 1	.06
1981	No. 2	.06
1982	No. 3	.06

B SPIRAL RATCHET SCREWDRIVER — QUICK CHANGE

A flip of the ratchet lever and you go from forward, to reverse, or to the locked position. Has quick-return spring in handle to permit one-hand operation. Will drive or draw screws from #4 through #8 with speed and ease. Handle is of clear grained hardwood. All parts beautifully machined. Comes complete with one ¼" bit.

No.	Overall Length With Bit	Wt. Lbs.
1975	10"	.50

C Accessory Set for P&C No. 1975 Ratchet Screwdriver

Adds to the uses to which you can put your Ratchet Screwdriver. Includes 5/32" cabinet bit; drill points 1/16", 5/64", 3/32"; one ⅜" countersink.

No.	Wt. Lbs.
1976	.13

*P & C . . . QUALITY Tools for building America!***P&C****GLASS CUTTERS****A****B****C**

P&C Glass Cutters give a clean cut that breaks away easily without ragged edges or splintering. Wheels stay sharp and run true. Handles are designed to fit the hand for greatest comfort in use and maximum control of the cutter.

A TURRET HEAD CUTTER

This is the original of this design and is famous for high grade performance. Turret turned from solid bar steel and heat treated for maximum wear. Six tested wheels mounted on numbered turret axle can be used successively. A top grade tool at low cost.

No.	Overall Length	Wt. Lbs.
1985	5½"	.07

B BREAKER-BALL CUTTER

This well balanced cutter comes with a breaker-ball for tapping the cut. Has type "D" wheel and three widths of breaker notches.

No.	Overall Length	Wt. Lbs.
1986	5"	.08

C EASY-USE CUTTER

This cutter fits the hand naturally and can be used for long periods without fatigue. Equipped with a type "D" cutter. Has three standard widths of breaker notches to fit most glass thicknesses.

No.	Overall Length	Wt. Lbs.
1987	5¼"	.08

P&C is the fastest growing line of hand tools in the country . . . the result of growing user insistence on the quality and craftsmanship found in P&C.

P&C



A

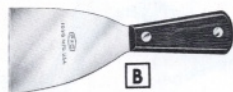

B

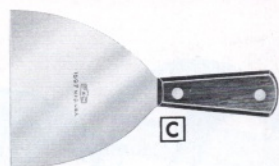

C

P&C Putty and Wall Knives are made of the best spring steel, tempered to achieve maximum flexibility and ease of use. Handles are of selected hardwood permanently fastened to the blade.

A PUTTY KNIFE

Tapered blade for maximum flexibility. Highly polished to get smooth putty flow. Hang-hole in handle.

No.	Blade Width	Wt. Lbs.
1695	1 1/4"	.14

B WALL SCRAPER

Blade is tapered for maximum flexibility and extends the full length of the handle.

No.	Blade Width	Wt. Lbs.
1696	3"	.27

C SPACKLING KNIFE

Tang extends the full length of the handle. Blade is square-ended, broad and mirror finished.

No.	Blade Width	Wt. Lbs.
1697	5"	.29

LEVELS



A



B



C



D



E



F

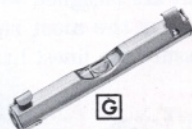

G

Levels that measure true and stay that way carry the P&C label. Glass vials are carefully set and skillfully locked in place. Edges are true and flat.

A PREMIER ALUMINUM LEVELS

Surfaces accurately milled. Glass protected vials have excellent visibility. Six vials permit instant reading, no matter which way you use the level.

No.	Dimensions	Wt. Lbs.
1920	18"	1.88
1921	24"	2.38
1922	28"	2.63

B ECONOMY ALUMINUM LEVEL

Has six vials to work any way, glass protected. Precision parallel grind on faces and edges.

No.	Dimensions	Wt. Lbs.
1927	24"	2.25
1928	28"	2.50

C MASON'S LEVEL - ALUMINUM

The tops, bottoms and ends of this rigid and lightweight aluminum level are true and parallel. Will not warp or rust. Has six cat's eye vials protected under heavy glass for years of trouble-free usage.

No.	Dimensions	Wt. Lbs.
1924	48"	4.13

D MASON'S LEVEL - METAL CLAD

Made from select, kiln-dried mahogany with double angle brass binding and strong brass end plates. Shock resistant permanently marked glass vials protected by glass windows.

No.	Dimensions	Wt. Lbs.
1925	48"	3.38

E TORPEDO LEVEL - ALUMINUM

Lightweight and handy. Permanently marked vials for accuracy. Base grooved for use on tubular work. Has plumb, level and 45° vials.

No.	Dimensions	Wt. Lbs.
1926	9" long	.34

F MAGNETIC ALUMINUM TORPEDO LEVEL

Has strong, lifetime magnet in edge that holds to iron or steel.

No.	Dimensions	Wt. Lbs.
1929	9" long	.37

G LINE LEVEL

Made of featherweight aluminum to prevent line sag. Has generous hooks with non-snap feature.

No.	Dimensions	Wt. Lbs.
1923	3/4" Hex x 3"	.04



Under the P&C label you will find a wide variety of the finest hammers available anywhere. All are designed with skill and manufactured under the most rigid inspection system to assure the finest hammers money can buy.

B TUBULAR STEEL HANDLE — COMMANDER SERIES

This is the finest nail hammer money can buy. Handle made of tubular steel with non-slip neoprene handle. Has bell face design with black painted poll and polished face and side. A beauty you'll be proud to use.

No.	Head Weight	Description	Overall	Weight Lb.
8413	13 oz.	Curved Claw	12½"	1.25
8416	16 oz.	Curved Claw	13"	1.58
8416-R	16 oz.	Ripping Claw	13"	1.58
8420	20 oz.	Curved Claw	14"	1.83
8420-R	20 oz.	Ripping Claw	14"	1.84
8420-RL	20 oz.	Ripping Claw, Long	16"	1.92
8420-RM	20 oz.	Rip. Claw, Milled Face	14"	1.84
8420-RLM	20 oz.	Rip. Claw, Long, Milled	16"	1.92

A TUBULAR STEEL HANDLE — ROYAL SERIES

A bell-faced tubular steel hammer for the economy-minded. Of finest grade steel and well balanced.

No.	Head Wt.	Description	Wt. Lbs.
8466	16 oz.	Curved Claw	1.58

A TACK HAMMER

Well balanced and strong magnet head that holds its magnetism. Solid hickory handle.

No.	Head Wt.	Description	Wt. Lbs.
8008	5 oz.	Magnetic Head	.41

B BRICK MASON'S HAMMERS

Perfect balance and proper wrist radius prevents straining. Chipping and cutting made easy with sharp, hardened chipper end.

No.	Head Wt.	Length of Head	Wt. Lbs.
8912	10-oz. Tile Setter	6"	.77
8920	1¼ lbs.	7¼"	1.35
8924	1½ lbs.	8½"	2.00

REPLACEMENT HANDLES FOR HAMMERS

Shaped for an exact fit. Made of the best grade, fine grain hickory.

For Hammer No.	Use Handle No.	For Hammer No.	Use Handle No.
8167	8167-H	8316	8316-H
8170	8170-H	8316-R	8316-H
8216	8316-H	8516	8316-H
8313	8313-H	8516-R	8316-H

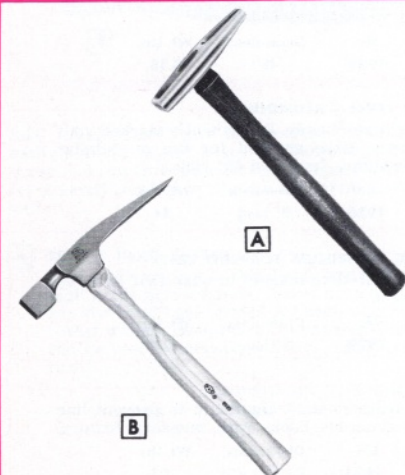

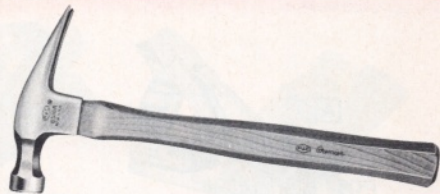
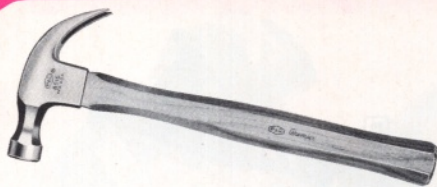
**HICKORY HANDLE — PREMIER SERIES**

Finest quality and appearance. Beautifully polished head with octagon neck. Fire hardened handle, straight grained in distinctive P&C oval shape.

No.	Head Wt.	Description	Wt. Lbs.
8516	16 oz.	Curved Claw	1.45
8516-R	16 oz.	Ripping Claw	1.45

HICKORY HANDLE — ROYAL SERIES

Drop forged with octagon neck. Polished face and back of claw. Particularly designed for today's competitive market. Oval, fire-hardened handle.

No.	Head Wt.	Description	Wt. Lbs.
8216	16 oz.	Curved Claw	1.45

HICKORY HANDLE — COMMANDER SERIES

Designed for the discriminating "Do-it-yourself" and professional carpenter. Oval fire-hardened handle that stays tight.

No.	Head Wt.	Description	Wt. Lbs.
8313	13 oz.	Curved Claw	1.20
8316	16 oz.	Curved Claw	1.45
8316-R	16 oz.	Ripping Claw	1.45

HICKORY HANDLE — CROWN SERIES

Black finish on heads with polished face and back of claw. Exceptional quality in the low price field.

No.	Head Wt.	Description	Wt. Lbs.
8170	7 oz.	Curved Claw	.65
8167	16 oz.	Curved Claw	1.45

HATCHETS

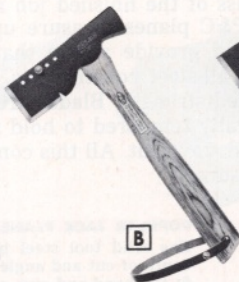

Balance, swing and keen cutting edges are the high points of P&C Hatchet design. Made of the best special alloy steels with cushion grip handles that absorb shock.

A TUBULAR STEEL HANDLE — HALF HATCHET

Has extra thin blade in carpenter's half hatchet design. Chrome plated tubular handle cannot come loose. Rubber cushion hand grip won't slip even when wet.

No.	Blade Width	Overall Length	Wt. Lbs.
8715	3½"	13"	1.58

C HICKORY HANDLE — HALF HATCHET

Head is forged in one piece and scientifically tempered. Has fire-hardened hickory handle that stays put. Handy nail puller forged in the head. Cushion grip.

No.	Blade Width	Overall Length	Wt. Lbs.
8716	3½"	13"	1.85

B LATHING-SHINGLE HATCHET

The shingler's favorite. Has thin blade with inside edge sharpened. Checker milled face. Gauge adjusts to five different positions. Easy grip fire-hardened hickory handle complete with leather safety thong.

No.	Blade Width	Overall Length	Wt. Lbs.
8720	2¼"	12"	1.80

D TUBULAR STEEL HANDLE — BELT AXE

The sportsman's favorite. Made of finest tool steel with beveled driving face to reduce mushrooming. Handle of chrome plated tubular boron steel. Cannot come loose. Leather sheath included.

No.	Blade Width	Overall Length	Wt. Lbs.
8719	3½"	13¼"	2.00

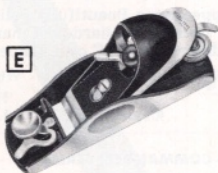
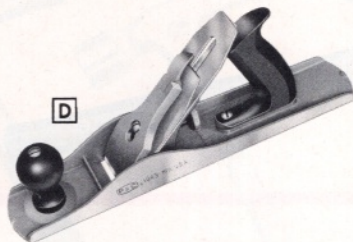
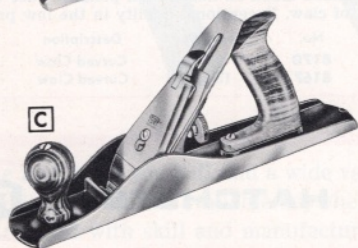
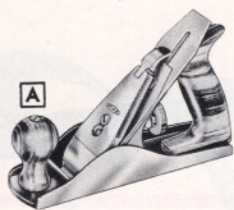

Balance, ease of use and the smoothness of the finished job are the criteria for judging a plane. On every score P&C planes measure up. Handles are scientifically shaped to fit the hand and provide a grip that gives certain control at all times. Plane bodies are all-steel construction, engineered to lighten weight without sacrificing needed strength. Blades are of finest steel sharpened with precision and scientifically tempered to hold an edge. Blade adjustment mechanism works easily and stays put. All this combines to make working with a P&C Plane a real pleasure.

A DELUXE BENCH PLANE

Quick and easy depth and side adjustment of the high carbon, tool steel blade. Polished bottom slides over the work. Tropical hardwood handles. A quality tool in every way.

No.	Length	Cutter	Wt. Lbs.
1940	9"	2"	4.25

D POPULAR JACK PLANE

Has solid tool steel blade. Easily adjustable for depth of cut and angle of blade. Knob and handle fit the hand and give complete plane control.

No.	Length	Cutter	Wt. Lbs.
1943	14"	2"	5.38

B POPULAR BENCH PLANE

An economy priced plane with years of built-in service. Depth and side adjustments work quickly and easily. Knob and handle are of clear-grained hardwood. Cutter is one solid piece of tool steel. Has smooth polished bottom.

No.	Length	Cutter	Wt. Lbs.
1942	9"	2"	4.00

E ADJUSTABLE THROAT QUALITY BLOCK PLANE

Gives you complete control of the amount of cut. Easy depth and side control of the blade. Has positive cam blade lock. Standard 20° angle.

No.	Length	Cutter	Wt. Lbs.
1944	6"	1 1/2"	1.50

C DELUXE JACK PLANE

A high quality plane for the craftsman or serious hobbyist. Attractive gray iron smooth bottom and frog. Three-point bearing lever cap is nickel plated. Handles of tropical hardwood. Full depth and side adjustment of special-analysis steel blade.

No.	Length	Cutter	Wt. Lbs.
1941	14"	2"	5.50

F LOW ANGLE BLOCK PLANE

Low angle (12°) is particularly good for working on end grain and hardwoods. Adjustable throat. Has screw depth adjustment of blade of solid steel specially hardened and tempered.

No.	Length	Cutter	Wt. Lbs.
1945	6"	1 1/2"	1.25

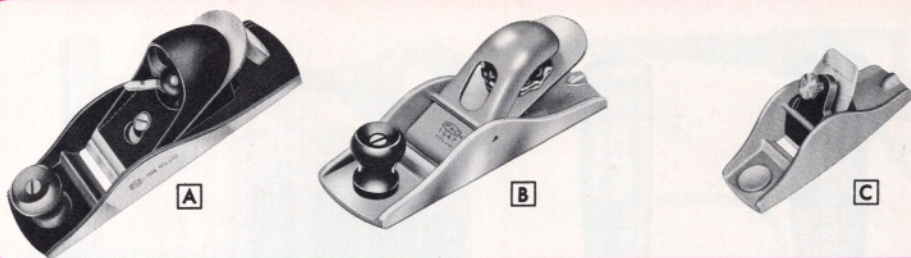

A POPULAR BLOCK PLANE
 Easy screw depth adjustment of blade. Tropical hardwood handle. Lever cam lock holds blade securely. Well balanced for one or two-hand use.

No.	Length	Cutter	Wt. Lbs.
1946	7"	1 3/4"	1.38

C MODEL MAKER BLOCK PLANE
 Designed for the close work encountered by pattern makers and model hobbyists. Specially fitted for one-hand operation.

No.	Length	Cutter	Wt. Lbs.
1948	3 1/2"	1"	.38

B STANDARD BLOCK PLANE
 Designed for general, all-around use. Has knob operated blade clamp. Blade is of solid tool steel scientifically heat treated. Operates at standard angle of 20°.

No.	Length	Cutter	Wt. Lbs.
1947	7"	1 3/4"	1.50

You get the smoothest planing job when you use a P & C Plane. Blades are easily adjusted and handles give balance for fatigue-free useage.

SCRAPERS, HAND SANDERS, PLUMB BOBS



A SCRAPERS
 This scraper is designed to work efficiently in removing paint, finishing woodwork or any other scraping job. Paint brush type handle gives you maximum pull and leverage. Tempered steel blade has four edges all told . . . two ready for instant use and two in reserve available by reversing the blade in the handle.

No.	Blade Width	Wt. Lbs.
1973	2 1/2"	.43
1973-B	Extra 2 1/2" blade	.13
1974	1 1/2"	.25
1974-B	Extra 1 1/2" blade	.06

For Automotive Scrapers, see page 51

B HAND SANDERS — PERMANENT TYPE
 This is the sander that has made sandpaper old fashioned. Made of tough, diamond-hard tungsten permanently welded to a tough steel back. Positively will not wrinkle, shred or tear. Each sander is complete and ready to use. Includes hand contoured wooden block (size 2 3/4" x 5 1/2") with 1/8" felt to cushion the steel abrasive sheet. Available in two grits.

No.	Grits	Wt. Lbs.
1684	Fine (150)	.30
1685	Medium (80)	.30

C PLUMB BOBS
 P&C Plumb Bobs hang accurately and true. Make line, level and point locating easier. Each one is accurately machined from cold rolled steel.

No.	Length	Wt. Oz.
1602	2 3/4"	2 1/2
1603	3 1/2"	5
1604	4 1/4"	8
1605	5"	12

Every P&C Tool is GUARANTEED against defects in workmanship or materials. You can buy P&C with confidence.



A



B

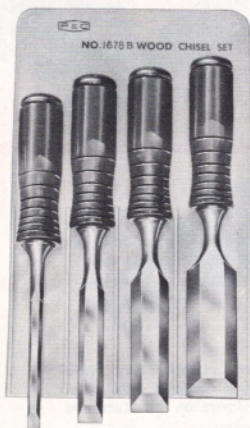

C



D

A BUTT CHISELS

Designed for heavy duty use. Tapered blade is 3" long and highly polished to resist rust. Cutting edge is scientifically ground for maximum ease of use. Tough "Tenite" handle has steel cap that gives a positive driving surface. Overall length 8½".

No.	Cut	Wt. Lbs.
1660	¼"	.38
1662	½"	.44
1664	¾"	.56
1665	1"	.56
1666	1¼"	.63
1667	1½"	.75

C No. 1678-B WOOD CHISEL SET

A popular set of four wood chisels in a handy plastic carrying case. Sizes show clearly. Chisels are 2½" blade length in ¼", ½", ¾" and 1" sizes. Set includes one each of the following:

Nos. 1670, 1672, 1674, 1675 Wt. 1.00 Lbs.

D PLUMBERS' ALL STEEL CHISELS

A favorite of plumbers because they can put them to the toughest useage. Made of special alloy chisel steel. Generous overall length to reach into hard-to-get-at spots.

No.	Cut	Stock	Blade Length	Overall Length	Wt. Lbs.
5-7/16	⅝"	⅞"	3¼"	9½"	.40
5-1/2	¾"	1½"	3½"	9¾"	.50
5-5/8	1"	⅝"	3¾"	10"	.70
5-3/4	1⅜"	¾"	4"	10½"	1.00

For a Complete Listing of P&C Quality
PLUMBER TOOLS see Pages 65 and 66

B WOOD CHISELS

A quality chisel specially designed for those who prefer a shorter, well balanced tool. Blade and bolster is hot forged in one piece from special high-carbon chisel steel. Heavy bolsters give real protection to the handle even under hardest useage. Blade is 2½" long for all widths. Overall length 7".

No.	Cut	Wt. Lbs.
1670	¼"	.19
1672	½"	.23
1674	¾"	.27
1675	1"	.29
1676	1¼"	.33
1677	1½"	.38

WING DIVIDERS

An accurate, easily adjusted divider ideal for layout work. Adjustments are spring-tensioned for greater accuracy. Made of pressed steel with hardened points and knurled adjusting screws. One leg adjustable and can be replaced with a pencil.

No.	Overall Length	Wt. Lbs.
1993	7"	.35

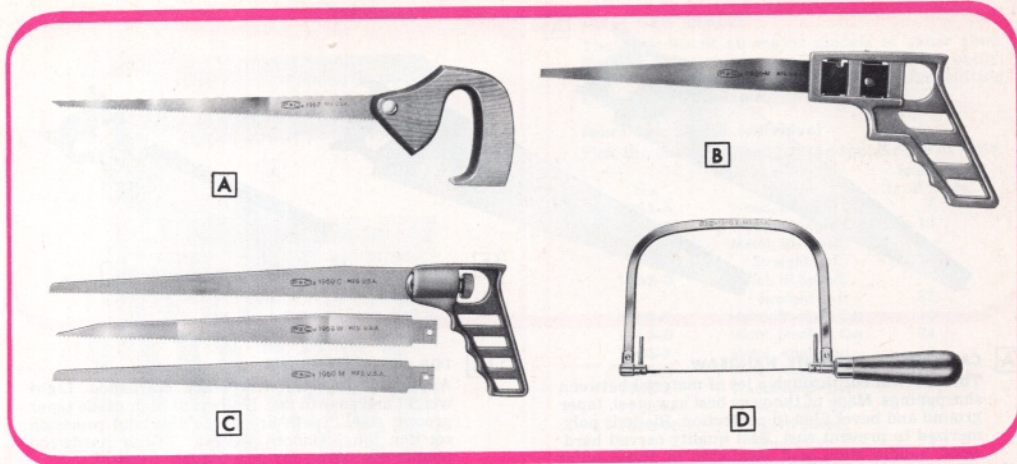

The measure of a saw is its ability to cut fast and true . . . to hold a set . . . to stay sharp with continued useage. On all these criteria you can count on P&C Saws. They are made from the finest steels. Each is shaped, tempered, sharpened and finished with skill that comes with years of saw making experience.

A COMPASS SAW

Two position handle for regular or flush cutting. Complete with #1967-K 14" 8-point blade of finest saw steel sharpened to perfection. Tough hardwood handle has large wing nut for easy position changing.

No.	Blade Length	Wt. Lbs.
1967	14"	.71

Extra Blades for No. 1967 Compass Saw			
No.	Teeth	Length	Wt. Lbs.
1967-K	8	14"	.19
1967-L	8	12"	.17

B KEYHOLE SAWS

Hand-fitting pistol grip. Tough metal-cutting blade goes through metal, wood, plastic, bone in a hurry. Blades easily changeable. Complete with one 18-tooth (No. 1966-M) blade.

No.	Blade Length	Overall Length	Wt. Lbs.
1966	7½"	10"	.30

Extra Blades for No. 1966 Saw Handle (Also for use in 1694 Handle)				
No.	For	Blade	Teeth	Wt. Lbs.
1966-M	Metal	7½"	18	.04
1966-N	Metal	7½"	24	.04
1966-W	Wood	7½"	9	.03

C KEYHOLE SAW COMBINATION SET

Form-fitting handle has quick-action chuck that makes blade changing easy. Blade can be turned and locked in any one of eight positions. Saw comes with blades Nos. 1969-C, 1969-M, 1969-W.

No.	Description	Wt. Lbs.
1969	Saw Combination Set with handle and three blades	1.51

Extra Blades for No. 1969 Saw Handle				
No.	Type of Blade	Teeth	Length	Wt. Lbs.
1969-C	Combination	10	12"	.10
1969-M	Metal Cutting	24	12"	.13
1969-W	Wood Cutting	7	12"	.13
1969-S	Special Dry Wall	9	5½"	.04

D COPING SAWS

Designed to be easy on blades . . . to give a more controlled cut. These frames are of high test spring steel and provide blade-stiffening tension. Studs hold either 6" or 6½" blades with either pin or loop ends. Blades can be rotated and locked in any position. Comfortable hardwood handle provides complete blade tension adjustment. Comes complete with one No. 1971-A blade.

No.	Depth of Throat	Wt. Lbs.
1970	4¾"	.56
1971	6½"	.69

EXTRA BLADES FOR P&C COPING SAWS

Available in both loop-end and pin-end design. Made of the best saw steel uniformly heat treated and sharpened for the finest and smoothest of cuts. No. 1971-A is a heavier blade.

No.	Type of End	Length	No. per Pkg.	Wt. Lbs.
1971-A	Pin	6½"	6	.01
1971-B	Loop	6"	6	.01

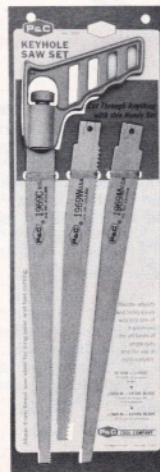

EASY TO DISPLAY SAW SET

Saw-set No. 1969 comes mounted on easy-to-display card for quick and easy display on all types of merchandising units.

**A CARPENTER'S FAVORITE HANDSAW**

This saw will cut through a lot of material between sharpenings. Made of the very best saw steel, taper ground and bevel filed to perfection. Blade is polymerized to prevent rust. Best quality carved hardwood handle stays put. Available in three point sizes.

No.	Size and Type	Points	Wt. Lbs.
1679	26" Cross Cut	8	2.00
1680	26" Cross Cut	10	2.00
1680-R	26" Ripping	5½	2.00

P&C Hand Saws cut true and hold their set.

B TOP VALUE HANDSAW

A popular favorite with home craftsmen. Light weight and easy to use. Blade is of high grade taper ground steel. Teeth are bevel filed and precision set for long, smooth cutting. Tough hardwood handle contoured for comfortable hand fit.

No.	Size and Type	Points	Wt. Lbs.
1681	26" Cross Cut	8	1.00

C BACK SAWS

Made from top quality steel to take a sharp tooth and accurate set. Ideal for use with P&C Hard Maple Mitre Boxes. Rigid back for straight cuts.

No.	Length	Wt. Lbs.
1934-5	12"	.57
1933-5	14"	1.25

MITRE BOXES

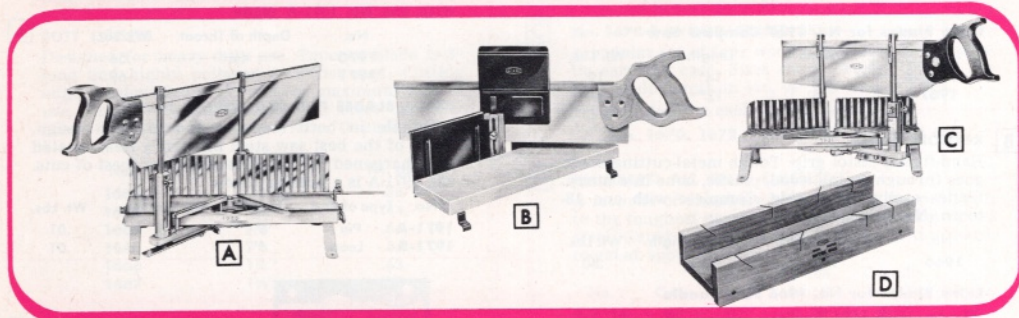
**A LANGDON ACME MITRE BOX**

One-piece cast iron back and bed. Steel swing lever and posts. Oilite bearing saw guides. Graduated arc and index plate. High grade saw included. Extendable swing lever swings right or left 90° and locks at any desired angle (automatically locks at most used angles). Automatic catch holds saw elevated. Capacity: 10½" at right angles, 7¼" at mitre.

No.	Saw Size	Wt. Lbs.
1930	28" x 5"	36

C POPULAR MITRE BOX

Similar to the well known Langdon Acme but smaller. One-piece cast iron bed and back. Swinging lever goes right or left, locks in most used positions. Automatic catch holds saw elevated when desired. Comes complete with top grade backsaw. Capacity: 8¾" at right angles, 6" at mitre.

No.	Saw Size	Wt. Lbs.
1931	24" x 4"	30

B ECONOMY MITRE BOX

Of sturdy steel and wood construction. Has die-cast saw guides and positive adjustable depth lock. Accurate angle cuts from 0° to 50°. Graduated index plate and quick-acting lock. Complete with saw.

No.	Saw Size	Wt. Lbs.
1932	4" x 16"	6.63

D HARD MAPLE MITRE BOX

Handy in any workshop. Made of selected, kiln dried rock maple. Extra broad 5" width. Has one 45° face mitre, two regular 45° mitres and one 90° square cut. Cannot become misaligned.

No.	Length	Wt. Lbs.
1933	12"	2.25
1934	16"	3.00



A SABRE SAW BLADES

These blades fit all major models of saber saws. Made from tough saw steel sharpened to cut easily. Won't break or bend. Both straight and fast cutting angle blades available.

Sabre Saw Blades, Individual

Pick the ones you need for the specific job at hand.

No.	Type	Teeth per In. of Blade
1963-A	Wood, Straight Cut	7
1963-B	Wood, Straight Cut	10
1963-C	Metal, Hi Speed, Straight Cut	14
1963-D	Metal, Hi Speed, Straight Cut	32
1963-F	Metal, Straight Cut	18
1963-G	Metal, Straight Cut	24
1963-J	Metal, Angle Cut	18
1963-K	Metal, Angle Cut	24
1963-L	Wood, Angle Cut	7
1963-M	Wood, Angle Cut	10
1963-N	Metal, Hi Speed, Angle Cut	14
1963-O	Metal, Hi Speed, Angle Cut	32

B SABRE SAW BLADE SET

Have the blade on hand when you need it. All the most used items in a handy plastic pouch. Can be hung on tool board if desired.

No.	Contents
1963-5B	Contains one (1) each of straight blades Nos. 1963-A, B, C, D and angle blades Nos. 1963-L, M, N, O.

BEVELS, TACK CLAW, NAIL SETS

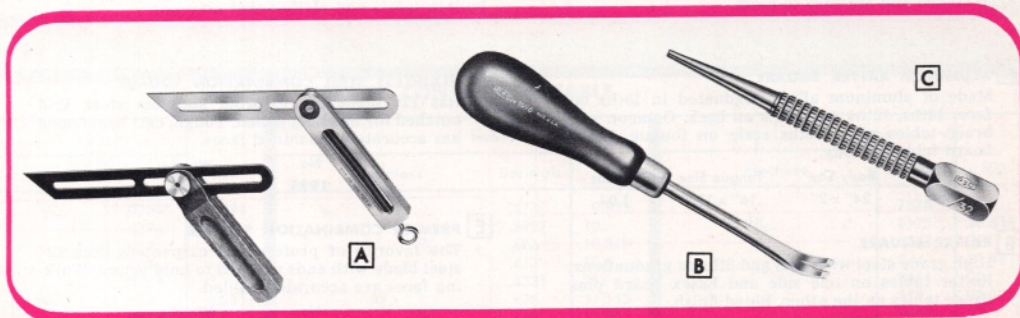

A BEVELS

Adjust easily and have positive locking devices that hold the angle when once set.

No.	Type	Blade Length	Wt. Lbs.
1601	Carpenters	8"	.25
1600	All Metal	8"	.58

B TACK CLAW

Makes quick work of pulling tacks of all kinds and types. Forged blade is of top grade tool steel.

No.	Blade Size	Overall Length	Wt. Lbs.
1698	$\frac{3}{32}$ " Diam.	7"	.19

C NAIL SETS

The choice of the finest cabinet makers. Made of molybdenum steel carefully heat treated. Points are cupped to work better. Body is deep knurled to prevent slipping. Head is square to prevent rolling and beveled to stop mushrooming.

No.	Point Diam.	Body	Length	Wt. Lbs.
1935	$\frac{1}{32}$ "	$\frac{3}{16}$ "	4"	.09
1936	$\frac{2}{32}$ "	$\frac{3}{16}$ "	4"	.09
1937	$\frac{3}{32}$ "	$\frac{3}{16}$ "	4"	.09
1938	$\frac{4}{32}$ "	$\frac{3}{16}$ "	4"	.09

P&C Tools Are User Tested —
Over 40 Years of It!

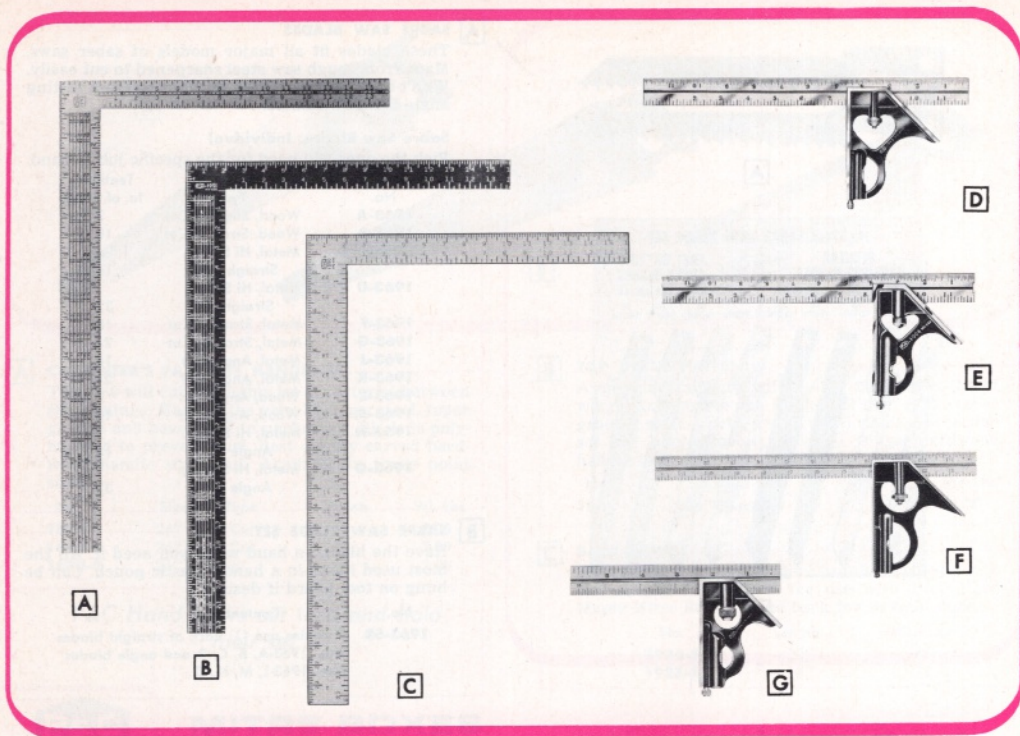

SQUARES

P&C Squares are made from a single piece of metal, hard rolled and shaped to amazing accuracy. Markings are deep etched and are easy to read.

A ALUMINUM RAFTER SQUARE

Made of aluminum alloy. Graduated in 16ths on face; 16ths, 12ths and 10ths on back. Octagon and brace tables plus 100ths scale on tongue. Essex board table on body.

No.	Body Size	Tongue Size	Wt. Lbs.
1992	24" x 2"	16" x 1½"	1.04

B RAFTER SQUARE

High grade steel with 4ths and 8ths as graduations. Rafter tables on one side and Essex board plus Brace tables on the other. Blued finish.

No.	Body Size	Tongue Size	Wt. Lbs.
1991	24" x 2"	16" x 1½"	2.00

C FRAMING SQUARE

Made of high grade steel graduated in 4ths and 8ths with Essex board measure and Brace tables on one side. Bright finish.

No.	Body Size	Tongue Size	Wt. Lbs.
1990	24" x 2"	16" x 1½"	2.00

COMBINATION SQUARES

All have grooved blades for a more positive hold. Markings are deeply etched and easily read. All have handy built-in levels and scribes that stay put.

D STAINLESS STEEL COMBINATION SQUARE

Has 12" blade of rustproof stainless steel. End notched for marking pencil. Tough, cast iron frame has accurately machined faces.

No.	Wt. Lbs.
1995	1.25

E PREMIER COMBINATION SQUARE

The favorite of professional carpenters. Has 12" steel blade with ends notched to hold pencil. Working faces are accurately milled.

No.	Wt. Lbs.
1994	.87

F ECONOMY COMBINATION SQUARE

Easy to read. Full 12" blade and accurate cast beam. Has spring-held scribe and double hairline level. A real value.

No.	Wt. Lbs.
1994-E	.75

G 6" POCKET COMBINATION SQUARE

A handy item when you are away from the bench. Has cast beam and grooved blade.

No.	Wt. Lbs.
1996	.38

Every P&C Tool is **GUARANTEED** against defects in workmanship or materials. You can buy P&C with confidence.

Standard Bolt, Nut and Screw Sizes Corresponding to Sizes of P&C Wrenches and Sockets

Thread Diameter of Bolt, Nut or Screw	AMERICAN STANDARD SERIES									
	HEAVY		REGULAR		LIGHT		Hexagon Full Finished Cap Screw Heads	Square and Hexagon Machine Screw Nuts and Square Stove Bolt Nuts	Square Set Screw Heads	Square Lag Bolt Heads
	Square and Hexagon Bolt Heads	Square Nuts and Hexagon Nuts, Jam Nuts and Slotted Nuts	Square and Hexagon Bolt Heads (Mach. Bolt Heads)	Square Nuts and Hexagon Nuts, Jam Nuts and Slotted Nuts	Hexagon Nuts, Jam Nuts, Slotted Nuts and Castle Nuts	Nat. Fine (SAE Thr.)				
		USS Nuts								
#0 & 1							5/32			
#2 & 3							3/16			
#4							1/4			
#5 & 6							5/16			
#8							11/32			
#10							3/8		3/16	
#12							7/16			
1/4"		3/8	3/8	7/16	7/16	7/16	3/8	1/4	3/8	
5/16"		11/32	1/2	3/8	3/8	1/2	5/16	5/16	1/2	
3/8"		11/16	3/8	3/8	3/8	3/8	3/8	3/8	3/8	
7/16"		23/32	3/4	3/4	3/4	3/4	3/4	3/4	3/4	
1/2"	3/8	7/8	3/4	13/16	3/4	3/4	1/2	1/2	3/4	
9/16"	13/16	15/16*	7/8	7/8	7/8	7/8	9/16	9/16	7/8	
5/8"	11/8	11/8	15/16	1	15/16	7/8	5/8	5/8	15/16	
3/4"	13/8	13/8	1 1/8	1 1/8	1 1/8	1	3/4	3/4	1 1/8	
7/8"	15/8	15/8	1 1/4	1 1/4	1 1/4	1 1/8	7/8	7/8	1 1/4	
1"	1 1/8	1 1/8	1 1/2	1 1/2	1 1/2	1 1/8	1	1	1 1/2	
1 1/8"	1 13/16	1 13/16	1 11/16	1 11/16	1 1/2	1 1/2	1 1/8	1 1/8	1 11/16	
1 1/4"	2	2	1 7/8	1 7/8	1 13/16	1 13/16	1 1/4	1 1/4	1 7/8	
1 3/8"	2 1/8	2 1/8	2 1/8	2 1/8	2	2	1 3/8	1 3/8		
1 1/2"	2 1/2	2 1/2	2 1/4	2 1/4	2 3/8			1 1/2		
1 5/8"	2 3/8	2 3/8	2 3/8	2 3/8						
1 3/4"	2 5/8	2 5/8	2 3/4	2 3/4						
1 7/8"	2 7/8	2 7/8	2 7/8	2 7/8						
2"	3	3	3	3						
2 1/4"	3 1/2	3 1/2	3 3/8	3 3/8						
2 1/2"	3 3/4	3 3/4	3 3/4	3 3/4						
2 3/4"	4 1/4	4 1/4	4 1/2	4 1/2						
3"	4 3/4	4 3/4	4 1/2	4 1/2						

HOW TO USE THIS CHART

To use this chart, locate thread diameter of bolt, nut or screw in extreme left column. Then move across to box which has proper identification of bolt, nut or screw at top of vertical column. The size in this particular box is the nominal opening size in inches of the P&C wrenches and sockets that will fit.

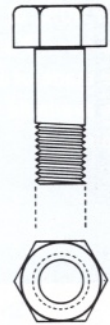

4- and 8-Point Sockets are used on Square Bolt Heads, Nuts and Screw Heads. 6- and 12-Point Sockets are used on Hexagon Bolt Heads, Nuts and Screw Heads.

*Does not apply to USS Nuts.

METRIC CONVERSION TABLE

Inches			Inches			Inches		
Fractions	Decimals	MM	Fractions	Decimals	MM	Fractions	Decimals	MM
1/32	.03125	.794	3/8	.375	9.525	13/16	.8125	20.638
	.0394	1.		.3937	10.		.8268	21.
	.059	1.5	13/32	.406	10.319		.844	21.431
1/16	.062	1.588		.413	10.5	27/32	.8661	22.
	.0787	2.		.4331	11.		.875	22.225
3/32	.094	2.381	3/16	.438	11.113	7/8	.8955	23.
	.0984	2.5		.469	11.906		.9055	23.019
	.1181	3.	15/32	.4724	12.	29/32	.9062	23.019
1/8	.125	3.175		.492	12.5	15/16	.9375	23.813
	.1378	3.5	1/2	.500	12.700		.9449	24.
	.156	3.969		.5118	13.	31/32	.969	24.606
	.1575	4.	17/32	.531	13.494		.9843	25.
	.177	4.5		.5512	14.	1	1.000	25.400
3/16	.1875	4.763	5/16	.563	14.288		1.0236	26.
	.1969	5.		.571	14.5			
	.2165	5.5		.5906	15.			
	.219	5.556	19/32	.594	15.081			
	.2362	6.	3/8	.625	15.875			
1/4	.250	6.350		.6299	16.			
	.2559	6.5		.6496	16.5			
	.2756	7.	21/32	.656	16.669			
	.281	7.144		.6693	17.			
	.2953	7.5	1/2	.6875	17.463			
	.312	7.938		.7087	18.			
5/16	.315	8.	23/32	.719	18.256			
	.335	8.5		.7283	18.5			
	.344	8.731	3/4	.750	19.			
11/32	.3543	9.		.780	19.050			
	.374	9.5	25/32	.781	19.844			

American and Metric wrench sizes are taken across the flats of the bolt head; British Standard size is taken from outside diameter of threads.

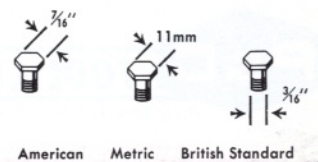

American Metric British Standard



Famous **wall-ette** SELF-SELLING DISPLAYS

The modern way to see, to try, to buy
hand tools of quality!

These versatile display units make it easy to assemble a P&C Tool Center on perforated hardboard panels. Each red, white and blue Wall-ette is clearly marked with tool name, size and other helpful information. Each displays fast-moving, heart-of-the-line tools that account for over 80% of hand tool sales. Over 40 units to choose from. P&C Wall-ettes will last for years because they're made of heavy gauge wire and metal. And they're available at no charge—you pay only for the tools!

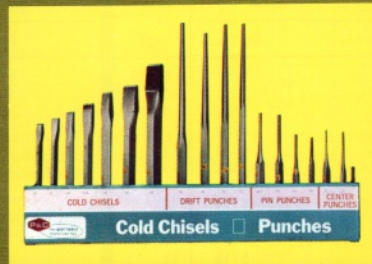
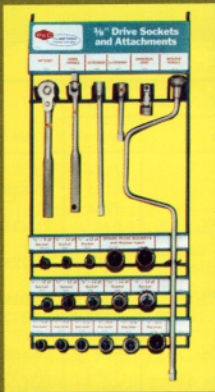
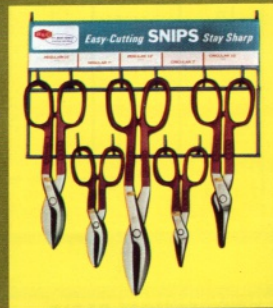
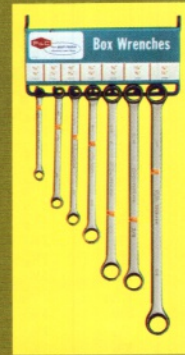

This is only a sample of P&C Wall-ettes. Ask for P&C Catalog No. PC65258 and pick the ones you need.



PC 66200
PRINTED IN U.S.A.
SKD-50M 266

FOR MORE INFORMATION ON P&C TOOL DISPLAYS, SEE YOUR P&C DISTRICT SALES MANAGER OR WHOLESALE DISTRIBUTOR